

**ELECTROCHEMICAL HYDRIDE GENERATION AND
TUNGSTEN TRAP ATOMIC ABSORPTION SPECTROMETRY FOR
DETERMINATION OF ANTIMONY**

**A THESIS SUBMITTED TO
THE GRADUATE SCHOOL OF NATURAL AND APPLIED SCIENCES
OF
MIDDLE EAST TECHNICAL UNIVERSITY**

BY

AHMET YILDIRAN

**IN PARTIAL FULFILLMENT OF THE REQUIREMENTS
FOR
THE DEGREE OF MASTER OF SCIENCE
IN
CHEMISTRY**

DECEMBER 2008

**ELECTROCHEMICAL HYDRIDE GENERATION AND TUNGSTEN TRAP
ATOMIC ABSORPTION SPECTROMETRY FOR DETERMINATION OF
ANTIMONY**

submitted by **AHMET YILDIRAN** in a partial fulfillment of the requirements
for the degree of **Master of Science in Chemistry Department, Middle
East Technical University** by,

Prof. Dr. Canan Özgen
Dean, Graduate School of **Natural and Applied Sciences** _____

Prof. Dr. Ahmet M. Önal
Head of Department, **Chemistry** _____

Prof Dr. O. Yavuz Ataman
Supervisor, **Chemistry Department, METU** _____

Examining Committee Members:

Prof. Dr. E. Hale Göktürk
Chemistry Department, METU _____

Prof. Dr. O. Yavuz Ataman
Chemistry Department, METU _____

Prof. Dr. R. Sezer Aygün
Chemistry Department, METU _____

Prof. Dr. Mürvet Volkan
Chemistry Department, METU _____

Associate Prof. Dr. Nusret Ertuş
Faculty of Pharmacy, Gazi University _____

Date: 05.12.2008

I hereby declare that all information in this document has been obtained and presented in accordance with academic rules and ethical conduct. I also declare that, as required by these rules and conduct, I have fully cited and referenced all material and results that are not original to this work.

Name, Last name: Ahmet Yıldırım

Signature :

ABSTRACT

ELECTROCHEMICAL HYDRIDE GENERATION AND TUNGSTEN TRAP ATOMIC ABSORPTION SPECTROMETRY FOR DETERMINATION OF ANTIMONY

Yıldıran, Ahmet

M.S., Department of Chemistry

Supervisor: Prof. Dr. O. Yavuz Ataman

December 2008, 69 pages

Electrochemical hydride generation is an alternative technique to the chemical hydride generation by NaBH_4 which is widely used for atomic spectrometric determination of volatile elements such as As, Bi, Ge, Pb, Sb, Se, Sn and Te. The aim of this research has been to develop an analytical technique at the level of ng/L for determination of antimony by using a simple and inexpensive AA spectrometer and the other parts that can be built in any laboratory. Carbon rod and platinum foil were used as cathode and anode materials, respectively, for the generation of antimony hydride. Argon was used as the carrier gas. Zr coated W-coil was used for on-line preconcentration of generated hydrides. A new apparatus independent from quartz T-tube atomizer was constructed and used to contain the atom trap. Zr coated W-trap was heated to the collection temperature for trapping the analyte species generated electrochemically. For the revolatilization of the

trapped species, the trap was further heated to the revolatilization temperature. Revolatilized species were transported to a flame-heated quartz tube atomizer where the analytical signal was recorded. During collection and revolatilization steps hydrogen gas was introduced into the system to prevent the oxidation of atom trap. The experimental operation conditions for electrochemical hydride generation and atom trapping were optimized. 3σ limit of detections were found to be 0.012 ng/mL and 0.41 ng/mL with and without using trap, respectively. The trap has provided 34 fold sensitivity improvement as compared with the electrochemical hydride generation alone. The interferences of some hydride forming elements and some transition metals on electrochemical hydride generation with and without employing the trap were investigated. Analysis of standard reference material was performed to check the accuracy of the proposed method.

Keywords: Electrochemical Hydride Generation, Preconcentration, Atomic Absorption Spectrometry, Tungsten Trap, Sb

ÖZ

ELEKTROKİMYASAL HİDRÜR OLUŞTURMA VE TUNGSTEN ATOM TUZAKLI ATOMİK ABSORPSİYON SPEKTROMETRİ YÖNTEMİ İLE ANTİMON TAYİNİ

Yıldıran, Ahmet

Yüksek Lisans, Kimya Bölümü

Tez Yöneticisi: Prof. Dr. O. Yavuz Ataman

Aralık 2008, 69 sayfa

Elektrokimyasal hidrür oluşturma, NaBH_4 kullanılarak gerçekleştirilen kimyasal hidrür oluşturma yöntemine alternatif bir yöntemdir ve uçucu elementler olan As, Bi, Ge, Pb, Sb, Se, Sn ve Te tayininde sıkça kullanılmaktadır. Bu araştırmanın amacı kullanımı kolay ve pahalı olmayan bir atomik absorpsiyon spektrometresi ve her laboratuvarında yapılabilecek diğer aygıtlar kullanarak ng/L seviyesinde antimon tayinini mümkün kılan analitik bir yöntem geliştirmektir. Antimon hidrür oluşturmak için geliştirilen elektrokimyasal hücre içinde anot ve katot yüzey olarak sırasıyla platin tabaka ve karbon çubuk kullanılmıştır. Taşıyıcı gaz olarak ise Ar gazı kullanılmıştır. Oluşturulan hidrür bileşiklerinin önderiştirme işlemi Zr kaplı W-sarmal kullanılarak yapılmıştır. Kuvars T-tüpten bağımsız olarak Zr kaplı W-tuzağı içerecek yeni bir bölüm tasarlanmıştır. Oluşturulan hidrür bileşiklerinin tuzaklanması için Zr kaplı W-tuzak biriktirme sıcaklığına kadar ısıtılmıştır. Tuzaklanan türlerin tekrar buharlaştırılması için ise Zr kaplı W-tuzak bırakma

sıcaklığına yükseltilmiştir. Tekrar buharlaştırılan türler, analitik sinyalin oluşması için alevle ısıtılmış kuvars tüp atomlaştırıcıya aktarılmıştır. Toplama ve bırakma süreci esnasında tuzağın oksitlenmesini engellemek amacıyla sisteme hidrojen gazı gönderilmiştir. Elektrokimyasal hidrür oluşturma ve atom tuzağı parametrelerinin optimize edilmesi sonucu 3σ gözlenebilirlik sınırı tuzaksız ve tuzaklı sistemler için sırasıyla 0.41 ng/mL ve 0.012 ng/mL olarak bulunmuştur. Tuzak sayesinde sistemin duyarlılığında yalnız elektrokimyasal hidrür oluşturma kullanıldığı duruma göre 34 kat artış sağlanmıştır. Bazı hidrür oluşturan elementlerin ve geçiş metallerinin tuzaklı ve tuzaksız elektrokimyasal hidrür oluşturma yöntemleri üzerinde girişim eklileri araştırılmıştır. Standart referans madde analizi yapılarak ileri sürülen yöntemin doğruluğu kontrol edilmiştir.

Anahtar Kelimeler: Elektrokimyasal Hidrür Oluşturma, Önderiştirme, Atomik Absorpsiyon Spektrometri, Tungsten Tuzak, Sb

To my family,

ACKNOWLEDGEMENTS

I wish to express my gratitude to my supervisor Prof. Dr. O. Yavuz Ataman for his guidance, encouragement and understanding throughout the research.

I am deeply grateful to Sezgin Bakırdere for his help, guidance and contribution in every part of this study.

I would like to thank to Betül Arı for her patience, endless help and support.

I offer special thanks to Feriye Şenol, Üftade Muşkara, Yasin Arslan, Tuğba Nur Aslan, Necati Koç and all AtaMAN Research Group Members for their understanding, patience and the support they have given to me.

Finally, I would like to thank Bilge-Özgür Bayraktar and my parents for their endless understanding, patience, encouragement and support.

A part of this thesis was financially supported by TÜBİTAK through grant 106T089.

TABLE OF CONTENTS

ABSTRACT.....	iv
ÖZ.....	vi
DEDICATION.....	viii
ACKNOWLEDGEMENTS.....	ix
TABLE OF CONTENTS.....	x
LIST OF TABLES.....	xiv
LIST OF FIGURES.....	xv
CHAPTERS	
1. INTRODUCTION.....	1
1.1 Atomic Absorption Spectrometry.....	1
1.2 Atom Traps for Flame Atomic Absorption Spectrometry.....	1
1.2.1 Slotted Quartz Tube.....	2
1.2.2 Water-Cooled Silica Trap.....	3
1.3 Hydride Generation.....	4
1.3.1 Vapor Generation and Atom Traps.....	5
1.3.1.1 Quartz and Metal Atom Traps With Vapor Generation.....	5
1.3.1.2 Coating of W-coil Trap.....	7
1.4 Electrochemical Hydride Generation (ECHG).....	7

1.4.1 An Alternative Way to Chemical Hydride Generation: Electrochemical Hydride Generation	8
1.4.2 Common Electrode Materials Used in ECHG	10
1.4.3 Reactions on the Cathode Surface.....	10
1.4.4 Pre-treatment of the Cathode Surface.....	11
1.4.5 Electrochemical Hydride Generators	12
1.5 Interferences.....	13
1.5.1 Interferences in Chemical Hydride Generation.....	13
1.5.2 Interferences in Electrochemical Hydride Generation...	14
1.6 Determination of Antimony	15
1.7 Aim of the Study.....	17
2. EXPERIMENTAL.....	19
2.1 Apparatus and Materials.....	19
2.2 Chemicals and Reagents	20
2.3 Atomic Absorption Spectrometer.....	20
2.4 Electrochemical Flow Cell.....	20
2.5 Electrochemical Hydride Generation System.....	23
2.6 Trap System.....	25
2.7 Experimental Procedure.....	27
3. RESULTS AND DISCUSSION.....	31
3.1 Optimization of Electrochemical Hydride Generation Conditions	32

3.1.1 Optimization of Anolyte Acidity	32
3.1.2 Optimization of Catholyte Acidity.....	32
3.1.3 Optimization of Anolyte Flow Rate.....	34
3.1.4 Optimization of Catholyte Flow Rate.....	35
3.1.5 Optimization of ZnSO ₄ Concentration in Catholyte Solution.....	36
3.1.6 Optimization of Carrier Gas Flow Rate.....	37
3.1.7 Effect of Applied Electric Current.....	38
3.2 Analytical Figures of Merit	40
3.3 Comparison of Electrochemical Hydride Generation and Chemical Hydride Generation.....	41
3.4 Optimization of W-coil Atom Trapping Conditions for Sb Determination by Electrochemical Hydride Generation.....	44
3.4.1 Optimization of Collection Temperature for Zr coated W Atom Trapping.....	46
3.4.2 Optimization of Releasing Temperature for Zr-coated W Atom Trapping.....	47
3.4.3 Effect of Collection Period.....	48
3.4.4 Optimization of Flow Rate of H ₂ During Collection Step.....	49
3.4.5 Optimization of Flow Rate of H ₂ During Releasing Step.....	50
3.4.6 Analytical Figures of Merit for Zr-coated W-trap by ECHG-AAS.....	52

3.5 Discussion of System Performance and Comparison with Similar Studies.....	54
3.6 Determination of Sb(III) and Sb(V) without and with Zr-coated W Trap.....	56
3.7 Interference Studies.....	56
3.8 Analysis of Standard Reference Material.....	61
4. CONCLUSIONS.....	62
5. REFERENCES.....	64

LIST OF TABLES

TABLES

3.1 Optimum Conditions of Electrochemical Hydride Generation	39
3.2 Optimum Conditions for Chemical Hydride Generation Technique.....	42
3.3 Comparison of Electrochemical Hydride Generation and Chemical Hydride Generation Techniques.....	44
3.4 Optimum Conditions of Zr-coated W Trap ECHG.....	51
3.5 Comparison of Sb Determination by ECHG Between Similar Studies. Characteristic Concentration, C_0 ; Limit of Detection, LOD_{3s} , Enhancement Factor of Trap, E	55
3.6 Results of the Analysis of Standard Reference Material.....	61

LIST OF FIGURES

FIGURES

1.1 Slotted Quartz Tube (SQT) and its working principle.....	2
2.1 Schematic representation of electrochemical flow cell.....	21
2.2 Three dimension view of the bottom part of electrochemical flow cell	22
2.3 Three dimension view of the upper part of electrochemical flow cell	22
2.4 Scheme of electrochemical hydride generation system.....	24
2.5 Scheme of the electrochemical flow through cell	25
2.6 Separate view of trap apparatus	26
2.7 Combined view of trap apparatus	26
2.8 Electrochemical hydride generation system with W-trap.....	27
3.1 Optimization of anolyte acidity	33
3.2 Optimization of catholyte acidity	34
3.3 Optimization of anolyte flow rate	35
3.4 Optimization of catholyte flow rate	36
3.5 Optimization of ZnSO ₄ concentration in catholyte solution	37
3.6 Optimization of carrier gas flow rate	38
3.7 Effect of the applied electric current on the absorbance signal ...	39

3.8 Calibration plot for electrochemical hydride generation of Sb	40
3.9 Linear calibration plot for electrochemical hydride generation of Sb	41
3.10 Calibration plot of chemical hydride generation of Sb	43
3.11 Linear calibration plot of chemical hydride generation of Sb	43
3.12 Sb signal obtained by W-trap ECHG-AAS	45
3.13 Sb signal obtained by Zr coated W-trap ECHG-AAS	46
3.14 Optimization of collection temperature by Zr coated W-trap by ECHG-AAS	47
3.15 Optimization of releasing temperature for Zr coated W-trap by ECHG-AAS.....	48
3.16 Optimization of collection time for Zr coated W-trap by ECHG-AAS	49
3.17 Optimization of flow rate of H ₂ during collection step for Zr coated W-trap by ECHG-AAS.....	50
3.18 Optimization of flow rate of H ₂ during releasing step for Zr coated W-trap by ECHG-AAS	51
3.19 Calibration Plot of Zr-coated W-trap ECHG-AAS for determination of Sb.....	52
3.20 Linear Calibration Plot of Zr-coated W-trap ECHG-AAS	53
3.21 Calibration Plot of Lower Concentration of Zr-coated W-trap ECHG-AAS.....	54
3.22 Interference of arsenic, selenium, tin and lead on electrochemical hydride generation without trap.....	58
3.23 Interference of arsenic, selenium, tin and lead on electrochemical hydride generation with trap.....	59

3.24 Interference of iron, cobalt, copper and nickel on electrochemical hydride generation without trap.....	60
3.25 Interference of iron, cobalt, copper and nickel on electrochemical hydride generation with trap.....	60

CHAPTER 1

INTRODUCTION

1.1 Atomic Absorption Spectrometry

Atomic absorption spectrometry (AAS) is based on the absorption of electromagnetic radiation by neutral, ground state atoms produced by an atomizer. Atomic absorption spectrometry was introduced to the world of analytical chemistry in the mid 1950s. In 1955, Walsh [1] introduced hollow cathode light sources, flame atomizers and a modulated system and showed that the system works as a quantitative analytical tool.

1.2 Atom Traps for Flame Atomic Absorption Spectrometry

Although the sensitivity problem has been solved using the several techniques mentioned above, flame AAS is so simple and straightforward when compared to other atomization techniques that researchers tried to introduce novel sensitive systems that would preserve flame atomization. Most of these initial systems had designs to provide a longer residence time for analyte atoms; therefore the term trap was occasionally used, mostly meaning a delay for atomic species in the measurement zone. In more recent versions of atom trapping, the analyte species are actually immobilized on a suitable material that is a part of the apparatus and thus actually a pre-concentration takes place in a collection period prior to a re-

volatilization and re-atomization process to obtain the enhanced signal. The last two terms should be used carefully since either term can be used depending on the kind of atom trap employed [2].

1.2.1 Slotted Quartz Tube

The slotted quartz tube (SQT) was first utilized by Watling [3, 4] who has placed a heated slotted quartz tube with two slots at 120° to each other on the conventional flame. This tool provided a momentary improvement in sensitivity that is 2-5 fold in common for some elements such as Zn, Cd, Ag Co, Ni, Cu, Bi, As, Sb and Se. Schematic representation of the SQT is shown in Figure 1.1.

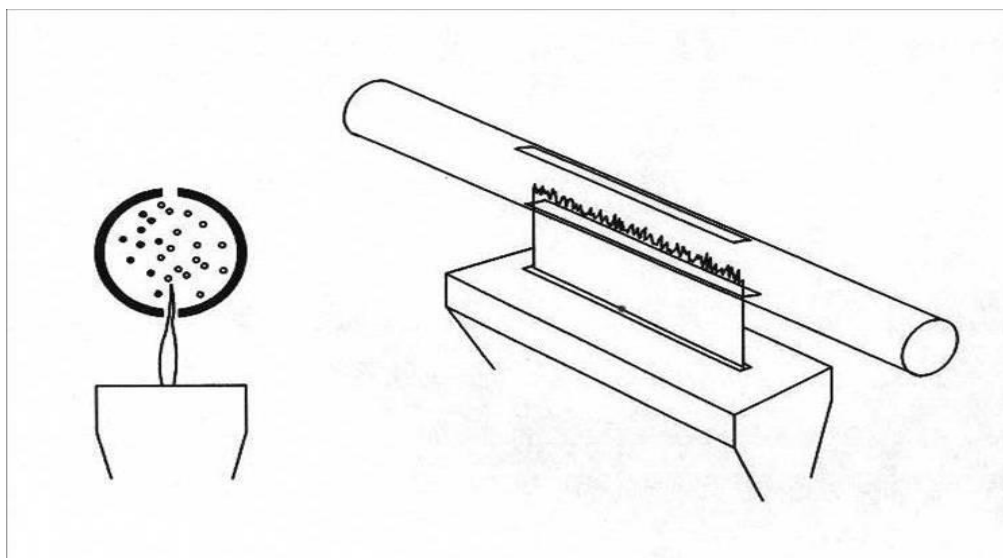

Figure 1.1 Schematic representation of Slotted Quartz Tube (SQT)

Huang et al. [5] utilized the slotted quartz tube for preconcentration of the analyte atoms. The slotted quartz tube is placed directly above the flame

with the narrower slot at the bottom. At a fixed collection time the sample solution is aspirated and preconcentration is achieved. Flame conditions are altered to atomize the preconcentrated atoms. 70-270 fold increase compared to conventional flame AAS was achieved for volatile elements.

It should be noted that the angle between the slots may be 120° or 180°, both configurations have been used. Although in these preliminary studies the SQT device was used with various flames, such as air/acetylene, air/hydrogen and argon (entrained air)/hydrogen, once the device was fairly popular, only air/acetylene was used in later studies. The SQT atom trap is used as follows:

1. Using an optimized flame, sample solution is aspirated while the SQT is positioned above the flame. Analyte atoms are trapped on the inner surface of the SQT. This step usually takes a few minutes and called collection.
2. At the end of the collection stage, a rather low volume, 10-50 μL , of an organic solvent is introduced to the flame. This alters the flame composition for a very short period of time, sufficient to release analyte species from the quartz surface; this stage is called revolatilization. It has been reported that revolatilization does not depend on temperature changes in flame [2].
3. Revolatilization is followed by rapid atomization and a transient signal is obtained [2].

1.2.2 Water-Cooled Silica Trap

This technique was developed by Lau et al. [6]. A water cooled silica tube with 4 mm o.d. and 3 mm i.d. was placed on an air-acetylene flame. A

sample solution is aspirated for a measured time interval and after the aspiration is stopped, water flow through the tube is replaced by air. Rapid heating of the silica tube is achieved and the trapped analyte species are released into the beam of the hollow cathode lamp. Consequently, a peak shaped analyte signal is obtained. This type of trap increased the sensitivity of the determination of volatile elements by 8-40 times [7].

Coating of the silica surface with aluminum or vanadium oxides improved the reproducibility in the determination of As, Cd, Pb, Se and Zn and also increased the lifetime of the silica trap tube [8].

Ertuş [9] introduced the trap system which is a combination of a water-cooled trapping system and the slotted quartz tube. The sensitivities for Pb and Cd were increased 50-200 times by positioning a slotted quartz tube and double slotted quartz tubes on the water-cooled atom trap. This increase is attributed to the increase in the residence time of the analyte atoms in the optical path.

Another trap designed by Matusiewicz [10] is composed of a slotted tube atom trap with a water-cooled silica tube trap passing through it. In this study, determination of Ag, Cd, Cu, Fe, In, Pb, Tl and Zn in beer was performed.

1.3 Hydride Generation

The hydride generation (HG) technique which makes use of a separation of the analyte element from the matrix by conversion to its volatile hydride offers a route to the trace analysis of several important elements which have

specific problems when analyzed by conventional methods. The technique comprises several distinct processes, namely hydride generation, hydride collection (optional) and atomization [11]. The technique is limited to a small number of elements, which include arsenic, antimony, bismuth, germanium, lead, selenium, tellurium and tin. Although the number of the elements is limited, HG is a valuable technique for the determination of very low levels of these elements.

Hydride generation was first used as sample introduction technique in atomic spectrometry in 1969 by Holak [12] to determine arsenic.

1.3.1 Vapor Generation and Atom Traps

Atom-trapping atomic absorption spectrometry is a technique that allows detection at the ng/L level for several analytes such as As, Se, Sb, Pb, Bi, Cd, In, Tl, Te, Sn and Hg. The principle involves generation of volatile species, usually hydrides, trapping these species on the surface of an atom trap held at an optimized temperature and, finally, revolatilizing the analyte species by rapid heating of the trap and transporting them in a carrier gas to a heated quartz tube, as commonly used with hydride generation AAS systems. A transient signal having, in most cases, a full width at half maximum of less than 1 second is obtained [2].

1.3.1.1 Quartz and Metal Atom Traps With Vapor Generation

A novel silica trap for lead determination by hydride generation atomic absorption spectrometry was proposed by Korkmaz [13], who has used an

externally heated silica tubing as the trapping medium. In this study, trapping and signal formation consisted of the following stages:

1. Lead hydride (PbH_4) is chemically formed by reaction of analyte in a HCl solution with NaBH_4 in a continuous flow system.
2. Analyte vapor separated from the liquid stream by a gas-liquid separator is directed to the quartz T-tube and passed through the trap held at an optimized collection temperature; some of the analyte hydride molecules are trapped here.
3. At the end of the collection stage, analyte introduction is stopped.
4. The trap is rapidly heated to its revolatilization temperature; release of analyte species takes place when pumps are reactivated, transporting and mixing HCl carrier and NaBH_4 flows to produce H_2 gas. The resultant volatile species are transported to the quartz T-tube atomizer where the transient signal is formed and recorded as a result of analyte atomization in the measurement zone.

An alternative to on-line trapping and hydride generation atomic absorption spectrometry is the use of a W-coil as a trap. A W-coil atom trap can be resistively heated by passing electricity directly through this device while external heating is required for the quartz trap; therefore, higher heating rates can be achieved for the former. The tungsten coil is taken from a commercial visible tungsten lamp; it can be readily and economically obtained, used and replaced when a new one is needed [2].

The use of tungsten coil for online preconcentration of bismuthine formed by NaBH_4 reduction was studied by Cankur [14]. Bismuthine formed by NaBH_4 reduction was trapped on a tungsten coil previously heated to $270\text{ }^\circ\text{C}$. The analyte species were re-volatilized by increasing the coil temperature to

1200 °C and then transported to an externally heated silica T-tube by using a mixture of argon and hydrogen as the carrier gas.

1.3.1.2 Coating of W-coil Trap

W-coil trap is a powerful preconcentration technique for determination of volatile species. However, some additional operations may increase the trapping efficiency of W-coil trap. Coating of W-coil surface with some metals is one of them.

Kula et al. [15] studied on selenium determination using hydride generation gold-coated W-coil trapping atomic absorption spectrometry. A novel technique was used to make gold plating on W-coil. Ultra pure gold wire was dissolved using aqua regia to prepare a solution of 1000 mg/L. Twenty five mL of this solution was placed in a 100 mL separatory funnel; 10 mL of methyl isobutylketone (MIBK) was added. The contents were shaken for 20 s. Then, organic solvent was separated from water. Using a micropipette, 25 µL of Au-MIBK solution was injected on the surface of W-coil. The W-coil was resistively heated to 165 °C and was kept at this temperature for 2.0 s. This procedure was repeated three times for one coating by using a total volume of 75 µL of Au-MIBK solution. Since no water was in contact with W-coil surface, corrosion during the process has been eliminated.

1.4 Electrochemical Hydride Generation

Applications of electrolysis are widespread in analytical chemistry, whereby electrolytic sample pre-treatment such as electrochemical dissolution of

samples, removal of the interfering sample matrix, or electrodeposition for analyte enrichment are significant. The electrolytic generation of volatile hydrides of As, Se, Sb, Sn, Ge, Pb, Bi and Te is one example of electrolytic sample pre-treatment in trace element analysis that shows the advantage of nearly 100% sample introduction compared to solution nebulization which is 5-10% [16].

Rigin [17] introduced the electrochemical hydride generation (ECHG) to atomic spectroscopy in the batch arrangement to reduce As to its hydride in alkaline media to detect by atomic absorption and atomic fluorescence. They used batch generator with platinum or lead spiral cathode. The first miniaturized continuous running cells were developed by Brockman [18] and Lin [19]. In these systems, the electrolyte was continuously conveyed by a multiple channel peristaltic pump. The sample solution was introduced into the catholyte, used as the carrier stream, by a sample loop and transported to the electrochemical cell. The gaseous reaction products formed at the cathode, rinsed out of the cell with the catholyte and separated from the aqueous solution in a subsequent membrane gas-liquid separator. The hydrides were transported to an electrically heated quartz cell with an argon carrier gas stream and determined under usual operating conditions for hydride forming elements by atomic absorption spectrometer.

1.4.1 An Alternative Way to Chemical Hydride Generation: Electrochemical Hydride Generation

Electrochemical hydride generators were developed as an alternative to the wet chemical ones used in routine analysis because electrolytic hydride formation has several advantages compared to the wet chemical approach.

First of all, this technique relieves the use of sodium tetrahydroborate in high-purity acidic media as the reduction system, which is commonly used in wet chemical hydride generation. NaBH_4 is an expensive reagent and is susceptible to introducing contamination, its aqueous solution is unstable and it has to be freshly prepared each working day. Using electrochemical hydride generation technique with a flow injection hydride generator, low consumption of expensive, high purity acids and sample as well as high sample throughput and automation can be achieved. Also, the electrochemical hydride generation does not depend on the oxidation state when using cathode materials with a high hydrogen overvoltage like Pb or amalgamated Ag. As a result, a pre-reduction step with KI or L-cysteine is not necessary and the cost and time per analysis is minimized. The interferences in the solution phase by matrix elements, like Cu, Fe, Ni, Co etc., and in the gas phase by other hydride-forming elements (when using a T-Tube atomizer in atomic absorption spectrometry) can be reduced (dependent on the cathode material used) compared to wet chemical hydride generation. Additionally, the electrochemical hydride generation technique is appropriate to speciation analyses such as the speciation of inorganic arsenic and selenium or the determination of arsenic in different oxidation states. On the other hand, there are some problems in electrolytic hydride generation. Firstly, the production of a reproducible solid electrode surface is not trivial. A strong relationship between the conditions of the surface of the cathode, the operating parameters, the type of solid cathode and the cathode material itself exists. The conditioning of the cathode surface has to be done daily or before changing the sample type or, when the signal does not return to the baseline. The formation of hydrides can be negatively- or positively affected by concomitant ions dependent on the cathode material and operation parameters [16].

1.4.2 Common Electrode Materials Used in ECHG

The generally useful electrodes are inert electrodes whose material of construction does not become involved in chemical or electrochemical reactions taking place at their surfaces. Generally employed cathode materials include Pd wire, Pt foils or Pt sheets, Pt wire, Pt covered Ag wool, Ag foil, Ag wool, Ag wire, amalgamated Ag foil, Cu cuttings, Cu powder, polished vitreous carbon, reticulated and crushed vitreous carbon, fibrous carbon, pyrolytic graphite, Pb covered fibrous carbon, Pb sheet (1 mm thick), Pb wire, Mo sheet, Cd sheet. The handling of cathode made of noble metals, especially Pt foil, is difficult regarding the conditioning of the cathode surface. The most useful cathode material seems to be carbon in its different forms and Pb because of its inertness to the sample matrix. Both of them have disadvantages such as the need of a pre-reduction step for a carbon cathode, or the susceptibility to interferences by some matrix elements in higher concentrations of a Pb cathode compared to using a platinum foil. The right choice of the cathode depends on the analytical problem [16].

1.4.3 Reactions on the Cathode Surface

The generation of volatile hydrides is a three-step reaction on the cathode surface:

1. Deposition of the hydride-forming elements onto the surface of the cathode and their reduction
2. Formation of the hydrides
3. Subsequent desorption of the hydrides

Before hydrogenation can take place, the hydride forming element has to be deposited on the cathode surface. The deposition is connected with the reduction of analyte in the acidified solution which is a charge transfer reaction [16].

The processes involved in electrochemical hydride generation can be summarized by the following overall reactions:

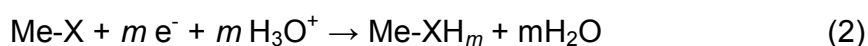

where Me is the cathode surface, X the hydride forming element and the source of hydrogen can be the hydronium ion or water [20].

Simultaneously, water is reduced to hydrogen on the cathode whereas it is oxidized in the separated anodic chamber and oxygen is formed [21].

1.4.4 Pre-treatment of the Cathode Surface

Aqueous work requires pre-treatment of the cathode surface to enhance repeatability. No information about the conditioning of the cathodes is given in the literature dealing with electrolytic hydride generation for analytical use. Usually two pre-treatment procedures are possible, the chemical one using chromic-sulfuric acid or hot nitric acid and the electrochemical one by anodic polarization. The most critical treatment of cathode surface is the conditioning of noble metal foils or sheets for hydride generation. The surfaces of the noble metals are contaminated by adsorbed hydrides. Such a deposit leads to a change in the potential and to a reduction of hydride production. The potential is reversible in the presence of hydrogen. Before

using a Pt cathode, the surface has to be conditioned by a highly concentrated analyte solution. The produced hydrides are adsorbed onto the activated sites of the cathode surface and the hydrides are dehydrogenated. After repeated rinsing, a constant potential is achieved. Only then can actual measurement be started [16].

1.4.5 Electrochemical Hydride Generators

The electrochemical hydride generators are generally composed of three components: a flow system, the electrochemical cell and a gas-liquid separator.

The flow system is employed for the transport of the electrolyte and the sample solutions. The electrochemical cell is the primary part of the electrochemical hydride generators. It is also composed of three parts: anode chamber, cathode chamber and an ion-exchange membrane. The hydrides are produced in the cathode chamber on the surface of the cathode. The ion-exchange membrane separates the anode and cathode chambers physically and prevents the diffusion of anode products into the cathode chamber. The hydrides and the excess of hydrogen are rinsed out of the electrochemical cell with the catholyte and separated from the aqueous solution in the gas-liquid separator and swept into the atomizer with an auxiliary carrier gas stream [16].

1.5 Interferences

In atomic absorption spectrometry two types of interferences are observed; spectral and nonspectral. Spectral interferences are observed due to radiation absorbed by species other than free atoms of the analyte and nonspectral interferences are due to the influence of sample constituents on the analyte signal.

1.5.1 Interferences in Chemical Hydride Generation

The main limitations associated with the use of this technique are the interferent effects of inorganic compounds. Inorganic interferences are divided into three groups: strong oxidants; ions of transition and noble metals; and hydride forming elements. In order to explain the effect of the elements on hydride generation, different mechanisms have been proposed which can be summarized as:

1. tetrahydroborate depletion
2. formation of insoluble species between the interferent ion and the analyte after the hydride has formed
3. Decomposition of hydrides on metal borides, or on colloidal metals formed by the reduction of the interferent ion [22].

The tetrahydroborate depletion mechanism was first suggested by Pierce et al. [23], and it is based on the competition between interferent ions and the analyte for reduction by tetrahydroborate. The formation of insoluble species between the interferent ion and the hydride was suggested by Meyer et al. [24] and supported by Welz and Melcher [25]. Smith [26] proposed that

interferences were based on the reduction of the interferent ion to its metallic form and the co-precipitation of the analyte or adsorption and decomposition of the hydride formed.

1.5.2 Interferences in Electrochemical Hydride Generation

Electrochemical hydride generation suffers from the same kinds of interferences as chemical generation, although its tolerance limits are different and dependent on the cathode surface. In electrochemical hydride generation, reaction does not take place in the homogeneous liquid phase, but on the surface of a cathode, which gives up electrons to the analyte or any other reducible species. The available surface of the cathode, as well as the residence time of the reducible species in the cathodic space and its concentration, influences the hydride generation efficiency and the appearance of interferent effects from concomitant species, because the different species are competing for the limited cathode surface. Reducible species on the cathode include: the analyte; protons from the acid; and interferents. To a first approximation, competition for available reduction sites on the cathode will be favored for species with high standard potential and high concentration. When the reduction products of the interferent are gases or soluble species, the nature of the cathode surface is not modified and the action mechanism is purely competitive. This kind of interference can be alleviated by increasing the cathode surface area or by increasing the residence time of the analyte in the cathodic space. If reduction products are solid species, such as transition and noble metals, they can be deposited on the cathode surface, modifying its nature and/or pass to the catholyte and act as liquid phase interferences. The interferences from different elements are related to their standard potentials $[E_0(M^{n+}/M^0)]$.

Therefore, the elements with positive standard potentials, such as copper and platinum can be easily reduced in an acidic medium to their metallic forms, whereas those with negative potentials, such as zinc, cannot be reduced [22].

Employing platinum cathode in flow injection mode, Lin et al. [19] investigated the effects of several interferent species for the determination of hydrogen selenide and concluded that interferences were significant for Cu (II), Ag (I), Sb (III) and Bi (III). The interference of copper and nickel on electrochemical generation of arsine, stibine and hydrogen selenide using lead, pyrolytic graphite, vitreous carbon and platinum as cathode materials was studied by Ding and Sturgeon [27].

1.6 Determination of Antimony

Antimony is a silvery-white metal. Although it is sometimes found free in nature, it mainly occurs as Sb_2S_3 and Sb_2O_3 .

Antimony has been known since ancient times. Its dissolving property of metals such as gold was used for purifying gold from copper and silver until the 18th century. Antimony increases the hardness and mechanical strength of lead. Batteries, antifriction alloys, type metal, cable sheating and minor products use about half the metal produced. The other half are found as sulfides, oxides, antimony trichloride and sodium antimonite. Sb_2O_3 is used in manufacturing flame-proofing compounds, ceramic enamels, glass, paints and pottery [28].

Antimony is an accumulative toxic element that is released to the environment from natural sources and from industry. The toxicity and biological behavior of the element depends on its oxidation state; Sb (III) is 10 times more toxic than Sb (V), which is why the determination of antimony species is essential for environmental studies [29].

Since its toxicity, there are many techniques to determine antimony. Hydride generation atomic absorption spectrometry has been the most widely used technique for determination of antimony species. Braman et al. presented the first work on the determination of antimony by antimony hydride generation using NaBH_4 as reducing agent [30]. Hydride generation technique was coupled with atomic absorption spectrometry by Fernandez to determine total antimony and also distinguish between Sb (III) and Sb (V) [31].

Electrochemical hydride generation is an alternative technique to the chemical hydride generation using NaBH_4 . It is also commonly used for the determination of inorganic antimony. Lin et al. [19] developed a flow injection-electrochemical hydride generation technique for atomic absorption spectrometry to determine arsenic, selenium and antimony. They designed a thin-layer type flow cell to deal with the small volumes of sample characteristic of flow injection techniques. The polytetrafluoroethylene (PTFE) body of the cell consisted of the upper (cathode) and lower (anode) blocks, each with solution inlets and outlets and cathode and anode embedded in them, separated by two slotted PTFE gaskets with an ion-exchange membrane in between. Ding and Sturgeon [32] developed a continuous flow electrochemical hydride generation system for the determination of total antimony in natural waters by electrothermal atomic absorption spectrometry with *in situ* concentration. Their plexiglas cell had

anode and cathode blocks. Lead and platinum were used as cathode and anode materials, respectively. They combined the electrochemical hydride generator with graphite furnace atomic absorption spectrometer with Zeeman-effect background correction. Laborda et al. [33] connected the tubular electrolytic hydride generator with atomic absorption spectrometer. Their electrolytic hydride generator consisted of a central cathode made of reticulated vitreous carbon inside a porous ceramic tube and an anode made of a coil of platinum wire surrounding the ceramic tube. Menemenlioğlu et al. [33] presented a study of electrochemical hydride generation combined with quartz atom trap atomic absorption spectrometry. They also produced antimony hydrides in thin-layer flow electrochemical cell which is made of plexiglas but they used lead and platinum foils as cathode and anode materials, respectively. Owing to quartz atom trapping, they could compete with the sensitivity of graphite furnace. Flow injection electrochemical hydride generation of stibine was combined with inductively coupled plasma time of flight mass spectrometer by Bings [35]. They designed a low volume electrolysis cell for flow injection analysis and the cathode and anode materials were fibrous carbon and platinum, respectively.

1.7 Aim of the Study

The main purpose of this study is generation of SbH_3 using electrochemical hydride generation technique and preconcentration of the generated hydrides on the heated W-trap. To accomplish this purpose, a new thin-layer electrochemical flow through cell was designed and constructed. The experimental operation conditions for electrochemical hydride generation and atom trapping were optimized. Interferences of copper, nickel, iron, cobalt, arsenic, selenium, lead and tin on electrochemical hydride generation

of antimony using spectral grade carbon rod cathode are to be examined. Finally in order to check the accuracy of the system, analysis of standard reference material will be performed.

CHAPTER 2

EXPERIMENTAL

2.1 Apparatus and Materials

The electrodes were platinum foil (99.9995%, Altın Yıldız İthalat-İmalat, Kapalıçarşı, İstanbul, Turkey) and spectral grade carbon rod as anode and cathode materials respectively. As an ion exchange membrane Nafion 117® perfluorinated membrane (Aldrich) was used.

Standard solutions were prepared in 100 mL volumetric flask and stored in 100 mL polyethylene containers. All standard solutions were prepared using adjustable micropipettes with polyethylene tips (Eppendorf, 100-1000 μ L and 500-5000 μ L). Gilson Minipuls 3 peristaltic pumps with Tygon® tubing were used to carry the anolyte and catholyte solutions into the electrochemical cell and to remove the waste solution from the gas-liquid separator.

Quartz tubes with different diameters were obtained from Quartz Scientific Inc., Fairport Hairbour Ohio. The quartz T-tubes were made in the glass shop of the Chemistry Department of our university. All of the quartz T-tubes had an optical arm length of 130 mm and an inlet arm length of 70 mm. Inlet arm was connected to the optical at right angle in the middle. The inner and outer diameters of inlet arm were 4 mm and 6 mm, respectively. The inner and outer diameters of optical arm were 13 mm and 15 mm, respectively.

2.2 Chemicals and Reagents

All reagents used during the experiments were of analytical grade. Standard solutions of Sb which were used as catholyte solutions prepared by appropriate dilution of the 1000 mg/L Sb standard ICP solution (Ultra Scientific) with 0.2 mol/L HCl (Merck). The anolyte solution was 4.0 mol/L H₂SO₄ (Merck). During the interference studies, standard solutions of Cu, Co, Ni, Fe, As, Se, Pb and Sn were prepared by appropriate dilutions of 1000 mg/L of their standard solutions. Deionized water from Milli-Q Water Purification System was used throughout the experiments.

2.3 Atomic Absorption Spectrometer

A Varian AA140 single beam atomic absorption spectrometer with D₂ background correction and home-made electrochemical hydride generator system was used throughout the study. The results were saved using the SpectrAA software of the AA instrument. Photron Sb hollow cathode super lamp with an operating current of 10 mA was used as the radiation source. All the analyses were done at the wavelength of 217.6 nm and 0.2 nm slit width. Air-acetylene flame with a 100 mm burner slot was used for atomization and argon was used as the carrier gas.

2.4 Electrochemical Flow Cell

A new thin layer electrochemical flow through cell which is made of Plexiglas was designed and used throughout the study (Figure 2.1, Figure 2.2 and Figure 2.3). It was consisted of two blocks which have cathode and anode

chambers on them. Both of the chambers had dimensions of 95 mm x 3 mm x 3 mm and an inner volume of 855 μ L. Nafion 117® perfluorinated membrane with 0.007 inch thickness was placed between two blocks as the ion exchange membrane. A carbon rod that was 2.7 mm thick, 90 mm long and 3 mm wide was placed inside the cathode chamber and a platinum foil that was 0.2 mm thick, 90 mm long and 3.0 mm wide was placed inside the anode chamber respectively. Eight screws were used to keep the two blocks as one piece.

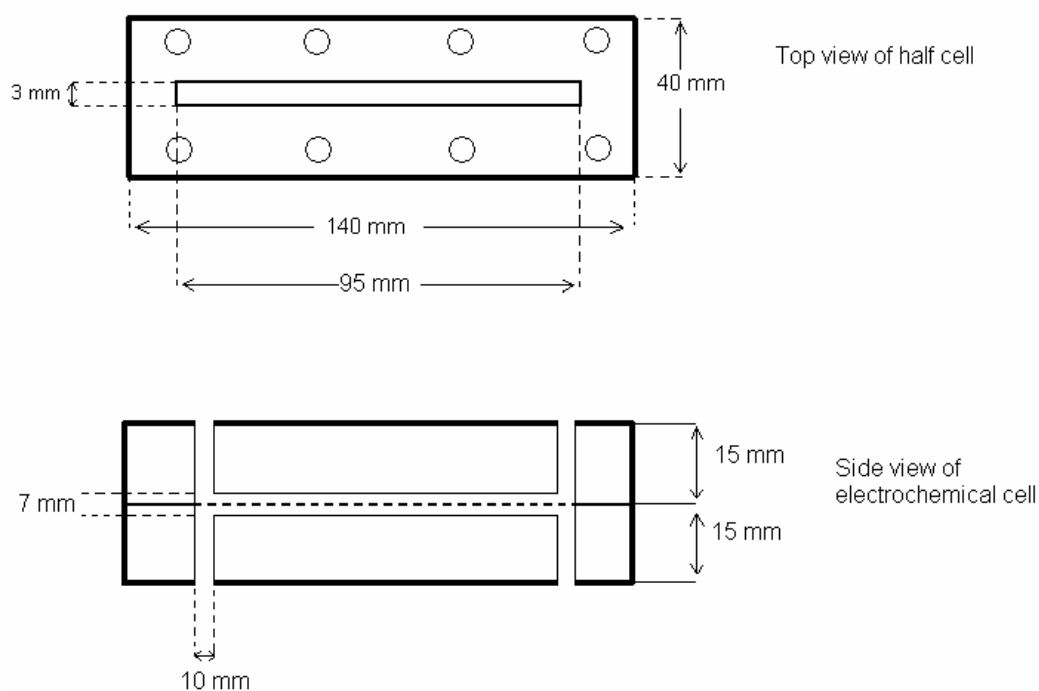

Figure 2.1 Schematic representation of electrochemical flow cell

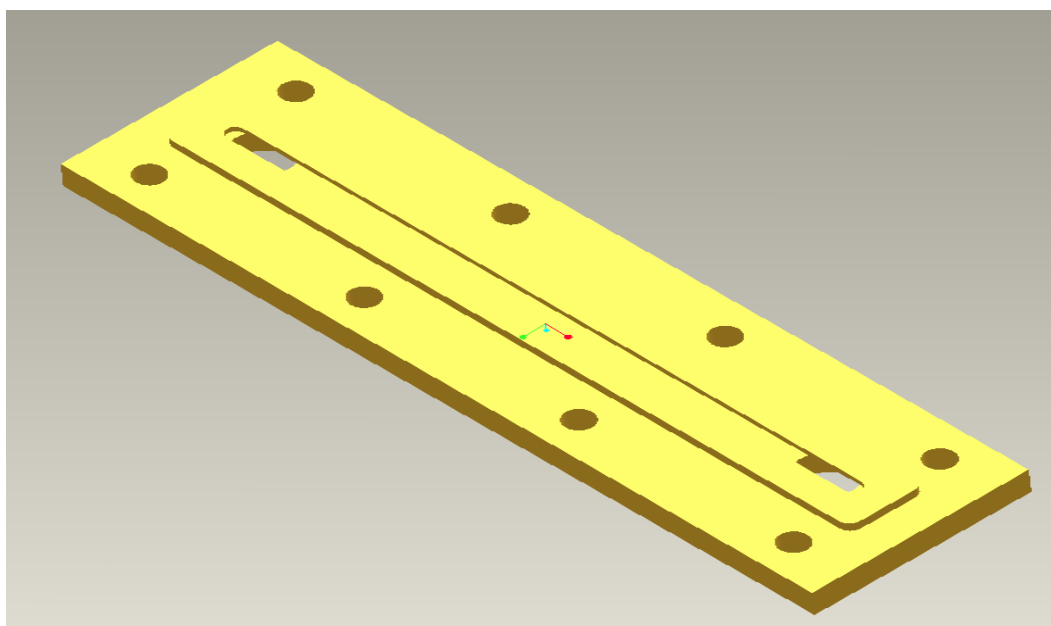

Figure 2.2 Three dimension view of the bottom part of electrochemical flow cell

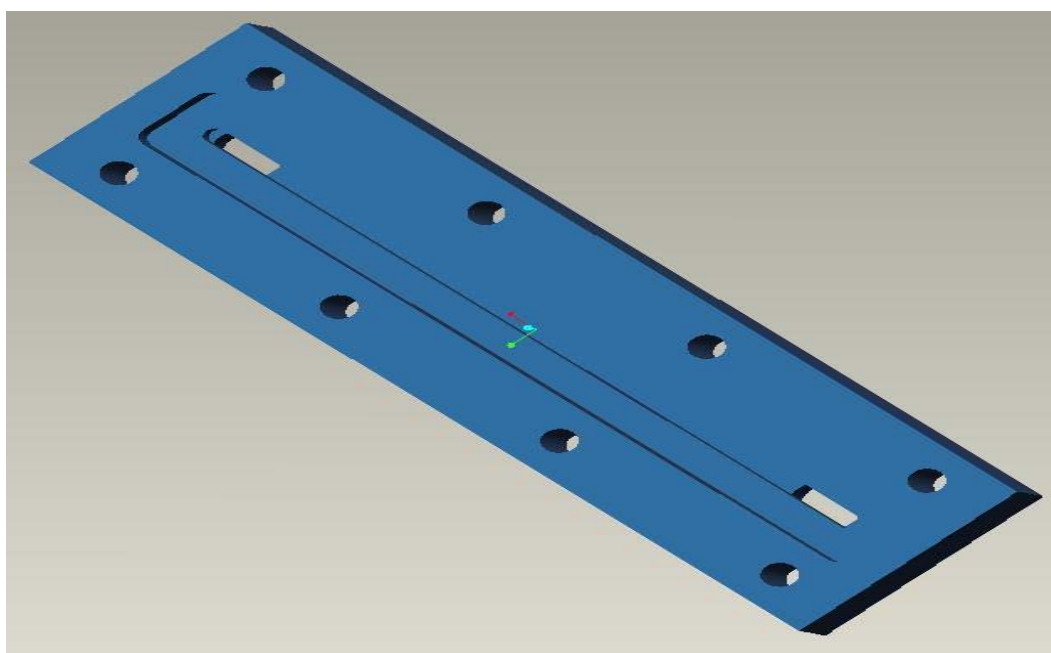

Figure 2.3 Three dimension view of the upper part of electrochemical flow cell

PTFE (polytetrafluoroethylene) tubings were connected to the inlets and outlets of cathode and anode chambers with tubing fittings which had 9 mm diameter.

A home made power supply with $I_{\max} = 2.5$ A and $U_{\max} = 100$ V was used to provide constant current to the electrochemical cell. Electric contact was established by platinum wires which were connected to the two electrodes respectively.

2.5 Electrochemical Hydride Generation System

The most important part of the electrochemical hydride generation system is the electrochemical cell. The anolyte and catholyte solutions were pumped through the anode and cathode chambers respectively with peristaltic pumps. The catholyte solution was either a blank or analyte in a dilute acid solution and the anolyte solution was diluted acid solution. The electrochemical cell was connected to the power supply and by applying current to the electrodes, hydrides were generated.

The outlet of the cathode chamber was connected to a 3-way connector (Cole-Parmer) by which argon was introduced to the gas-liquid separator with PTFE tubing. The gas-liquid separator was made up of a glass. Three tubings were inserted into a rubber bottom of the gas-liquid separator. One of them was used for introducing the generated hydrides and the excess hydrogen to the gas-liquid separator and the other tubings were used for pumping the liquid waste away. The gas outlet of the gas-liquid separator was connected to the quartz T-tube atomizer with Tygon tubing. The system is described schematically in Figures 2.4 and 2.5.

The flow rates of catholyte and anolyte solutions were 2.2 mL/min and 4.0 mL/min respectively. The anolyte solution that has passed from anode chamber was sent to waste. The flow rate of argon introduced into the system was controlled by using a Cole-Parmer gas flow meter.

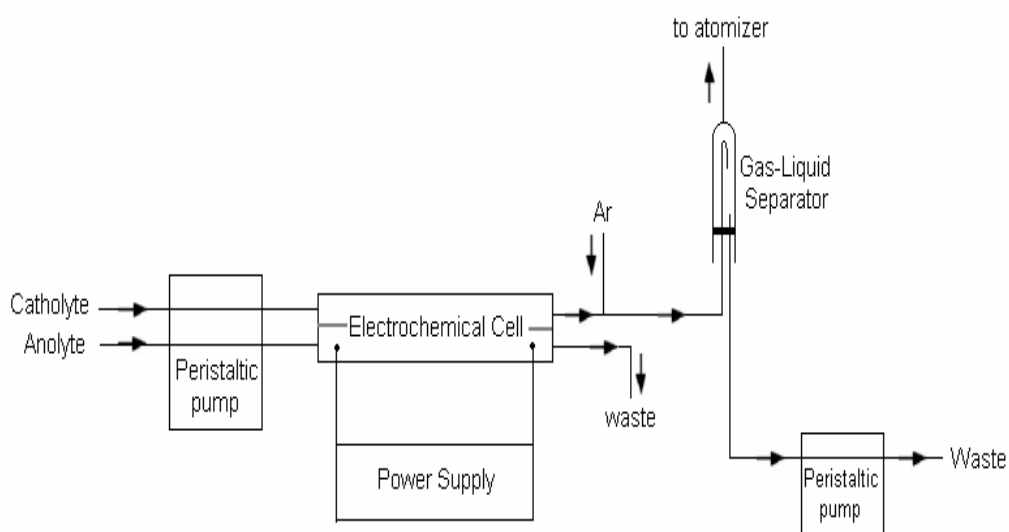

Figure 2.4 Scheme of the electrochemical hydride generation system

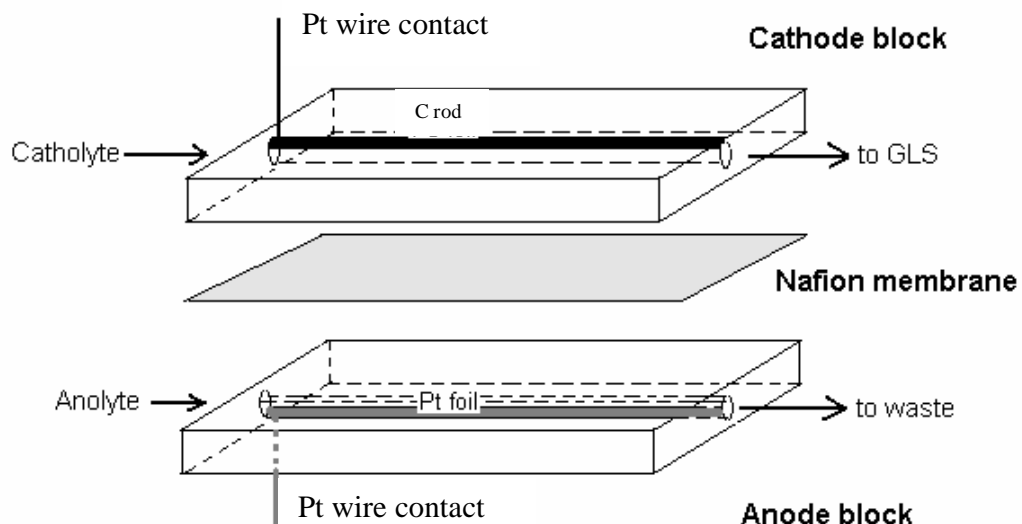

Figure 2.5 Scheme of the electrochemical flow through cell

2.6 Trap System

At the beginning of trap study, a tungsten filament extracted from a 15 V, 150 Watt Philips tungsten projector lamp was used to collect hydride species which were produced electrochemically. A new apparatus separate from quartz T-tube was designed to contain the W atom trap. All parts of this apparatus were made of glass except the part which is used for transporting the hydride species to the trap medium. The transport tubing was made of quartz as it was too close to the tungsten trap and could be affected from the trap temperature (Figure 2.6, Figure 2.7). Electrochemical hydride generation system with W-trap is shown in the Figure 2.8.

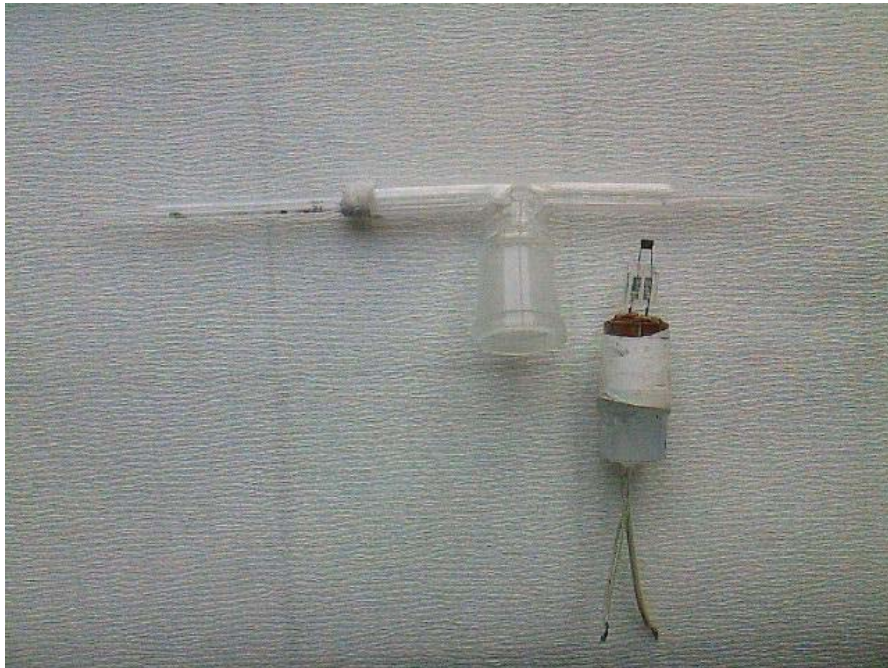

Figure 2.6 Separate view of trap apparatus



Figure 2.7 Combined view of trap apparatus

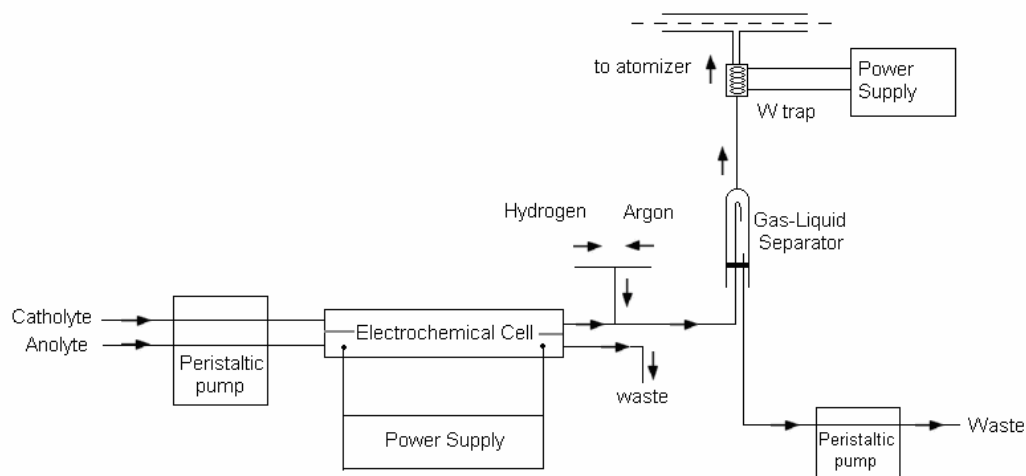

Figure 2.8 Electrochemical hydride generation system with W-trap

2.7 Experimental Procedure

First, the optimization of experimental parameters for electrochemical hydride generation were performed. Optimization was realized by keeping all parameters constant except the one which is being optimized. Several cycles were completed until optimized values do not show any variations. Before sending the catholyte solution to the electrochemical cell, 0.02 mol/L ZnSO_4 solution in 0.2 mol/L HCl was pumped to the cathode surface for 10 minutes to form a Zn layer on it. The use of Zn in the catholyte solution has been reported previously [36]. Zn layer was used to simplify the cleaning of the cathode surface. When the analytical signal decreased by 10%-15%, the cell was cleaned by pumping 2.0 mol/L H_2SO_4 to the cathode surface. Throughout the ECHG studies, cathode surface was cleaned after about 20 cycles. However, while using the atom trap, since the working concentration range was lower, the same cathode surface could be used for higher

number of cycles before cleaning, about 50 cycles. Since Zn is a soft metal, it can be easily removed from the surface by dilute H_2SO_4 . After cleaning process, cathode surface was coated with Zn again with 0.02 mol/L ZnSO_4 solution. Cleaning of cathode surface was done without disassembling. To generate the hydrides electrochemically, the catholyte solution which contained the sample in 0.2 mol/L HCl and 0.002 mol/L ZnSO_4 was pumped through the cathode chamber at a flow rate of 2.2 mL/min and the anolyte solution which was 4.0 mol/L H_2SO_4 was pumped through the anode chamber at a flow rate of 4.0 mL/min. After the flow rates were provided, constant electric current was applied to the electrodes and the hydrides were generated on the cathode surface. Ar flow of 73 mL/min was introduced and the products were transported to gas-liquid separator where the generated hydrides and the liquid were separated. Finally generated hydrides were sent to the quartz tube atomizer by carrier gas, atomized there and the absorbance signals were obtained.

After optimization of electrochemical hydride generation conditions, calibration plot was obtained and the limit of detection was calculated. To see the differences between chemical and electrochemical hydride generation techniques, calibration plot was constructed for the chemical hydride generation technique as well. Conditions for chemical hydride generation have been obtained from the article by Titretir et al. [37].

In second part of the experiment, trapping of the generated stibine was performed. The trap experiments were composed of two steps which were collection and volatilization. During the optimization studies, collection temperature, releasing temperature, collection time, Ar flow rate, H_2 flow rate, applied current parameters were optimized. The results are presented in Chapter 3.

In the collection period, Zr coated W-trap was heated up to 570 °C by increasing the applied voltage to the W-coil. Electrochemical hydride generation was started by sending the anolyte and catholyte solutions to the electrochemical cell by switching on the peristaltic pumps and also applying current to the electrochemical cell by switching on the power supply. During the collection period, the argon and hydrogen flow rates were 73 mL/min and 40 mL/min, respectively. The flow rates of anolyte and catholyte solutions were 4.0 mL/min and 2.2 mL/min, respectively. The collection time was 300 seconds during optimization of the parameters.

At the end of the collection period, the collection was stopped by switching off the peristaltic pumps and the power supplies of electrochemical cell and Zr coated W-trap. H₂ flow was increased up to 350 mL/min and trap temperature was increased up to 1480 °C in a second by increasing the applied voltage. The volatilization of the collected analytes took place and the absorbance signal was obtained. After obtaining the absorbance signal power supply of trap was switched off and H₂ flow was decreased to 40 mL/min and the experiment were carried on with the next collection step. Collection and releasing temperatures of atom trap were measured by GE XDD1DC096 model thermocouple and IRCON MR-3015-990 model pyrometer.

The interference effects of cobalt, copper, nickel and iron among the transition metals and arsenic, selenium, tin and lead among the hydride forming elements on electrochemical stibine generation were investigated. The interference studies were performed with and without trapping of the generated hydrides. The effect of every interferent ion was investigated by preparing standards with Sb / interferent ratios of 1:1, 1:10, 1:100 and 1:1000. The Sb concentration was 50 ng/mL for the experiments performed

without the trap and 20 ng/mL for the experiments performed with the trap. The hydrides were generated and the influences of every interferent on the absorbance signal at the four concentrations were investigated.

The standard reference material (SRM); Montana I Soil, Cat # SRM 2710 (NIST) was used for the validation of the proposed method. 0.200 g Montana I Soil SRM in 10 mL HNO₃ was decomposed with a Milestone Ethos Plus microwave oven and diluted to 25 mL. This solution was further diluted 20 times with 0.2 mol/L HCl and analyzed.

CHAPTER 3

RESULTS AND DISCUSSION

Electrochemical hydride generation and atom trapping conditions were optimized during optimization studies. In the electrochemical hydride generation part, anolyte acidity, catholyte acidity, anolyte flow rate, catholyte flow rate, ZnSO₄ concentration in catholyte solution, carrier Ar gas flow rate and electric current applied to the electrochemical cell were optimized. The calibration plot for the electrochemical hydride generation was obtained and limit of detection and characteristic concentration values were calculated. Electrochemical and chemical hydride generations were compared in terms of their linear range, limits of detection and characteristic concentration values. In the atom trapping part, collection temperature, releasing temperature, collection time, H₂ flow rate during collection period and H₂ flow rate during releasing stage were optimized. The calibration plot for the trap study was obtained and the limit of detection and characteristic concentration values were calculated. The effects of interfering elements were also investigated without and with trap. Finally, analysis of standard reference material was performed for accuracy check.

3.1 Optimization of Electrochemical Hydride Generation Conditions

All the optimizations were done by the continuous flow system using 50 ng/mL and 100 ng/mL Sb solutions prepared that are 0.2 mol/L in HCl and 0.002 mol/L in ZnSO₄.

3.1.1 Optimization of Anolyte Acidity

Anolyte acidity is one of the most important parameter in electrochemical hydride generation of SbH₃. Six different acid concentration of H₂SO₄ between 0.50 mol/L and 5.0 mol/L were tried. Although there was no significant change between concentrations of 2.0 mol/L and 5.0 mol/L H₂SO₄, the optimum anolyte acidity was chosen as 4.0 mol/L H₂SO₄ since more stable signal was observed in 4.0 mol/L H₂SO₄ (Figure 3.1).

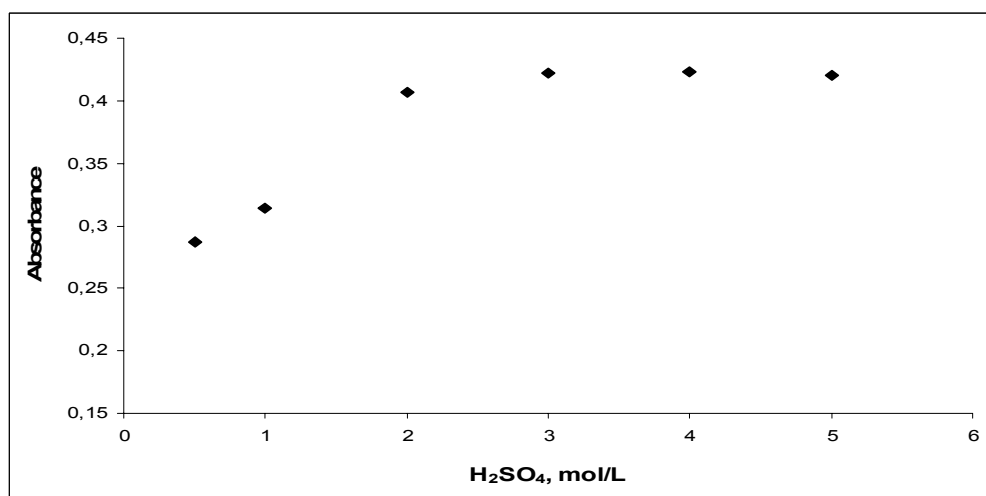

Figure 3.1 Optimization of anolyte acidity

Catholyte: 50 ng/mL Sb in 0.20 mol/L HCl and 0.0020 mol/L ZnSO₄, Flow rate of Ar: 73 mL/min., Current: 1400 mA, Flow rate of catholyte: 4.0 mL/min. Anolyte flow rate: 2.2 mL/min

3.1.2 Optimization of Catholyte Acidity

Optimization of catholyte acidity was carried in 0.10 mol/L - 2.0 mol/L HCl range containing 100 ng/mL Sb that was 0.20 mol/L in HCl and 0.0020 mol/L in ZnSO₄. The highest absorbance signal was obtained by the 0.20 mol/L HCl concentration and this catholyte acidity was chosen as the optimum condition (Figure 3.2). Reduction of signal at higher acidity may be because of the dilution effect by the hydrogen gas produced excessively.

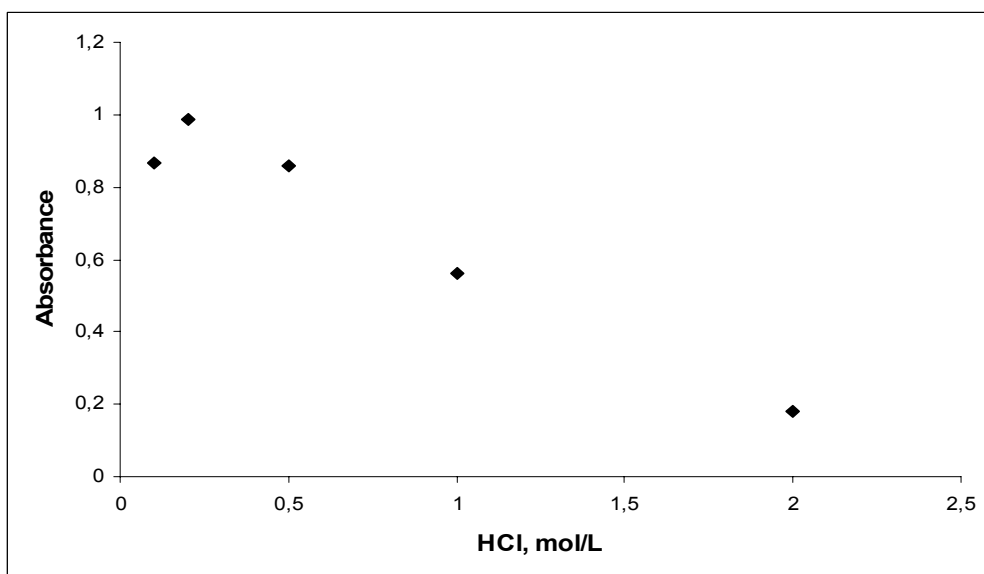

Figure 3.2 Optimization of catholyte acidity

Anolyte: 4.0 mol/L H₂SO₄, Ar flow rate: 73 mL/min, Current: 1400 mA, Catholyte flow rate: 4.0 mL/min, Anolyte flow rate: 2.2 mL/min

3.1.3 Optimization of Anolyte Flow Rate

The effect of anolyte flow rate was investigated in 0.75-3.5 mL/min interval. The optimum value which was producing the highest absorbance signal was determined as 2.2 mL/min (Figure 3.3).

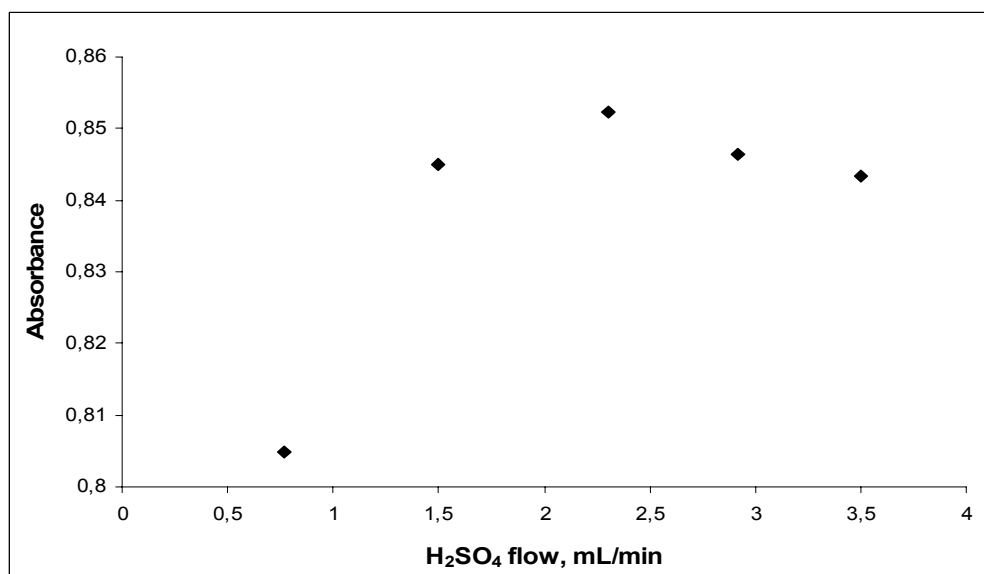
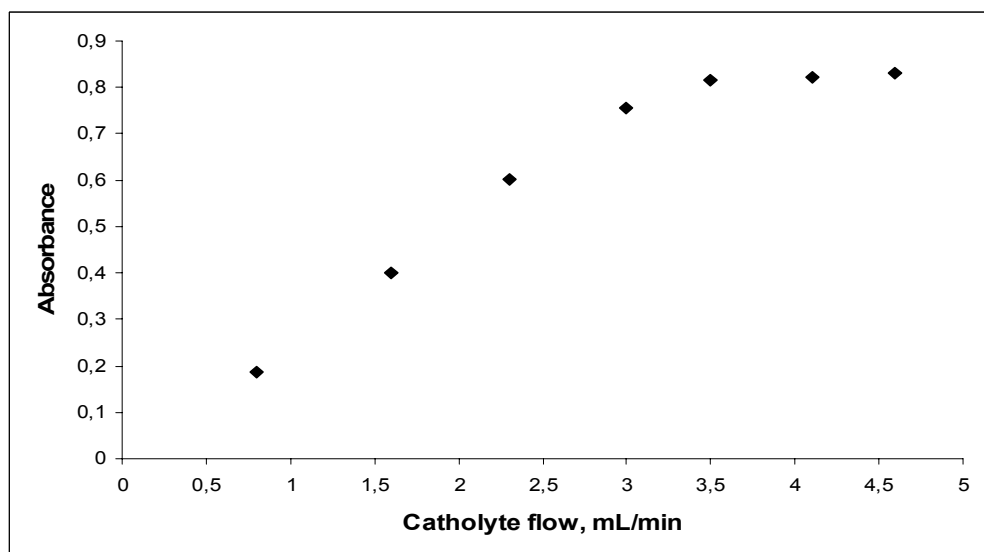

Figure 3.3 Optimization of anolyte flow rate

Anolyte: 4.0 mol/L H₂SO₄, Catholyte: 100 ng/mL Sb in 0.20 mol/L HCl and 0.0020 mol/L ZnSO₄, Ar flow rate: 73 mL/min, Current: 1400 mA, Catholyte flow rate: 4.0 mL/min

3.1.4 Optimization of Catholyte Flow Rate

Catholyte flow rate is the one of the crucial parameter for the electrochemical hydride generation method. As the the flow rate of catholyte increases, signal also increases. However, after a certain flow rate there was no enhancement in the signals at high flow rates, the cathode is not able to handle all of the sample introduced. In other words its maximum reducing capacity is exceeded by the larger amount of analyte. Based on Figure 3.4, the optimum catholyte flow rate was chosen as 4.0 mL/min.



3.4 Optimization of catholyte flow rate

Anolyte: 4.0 mol/L H₂SO₄, Catholyte: 100 ng/mL Sb in 0.20 mol/L HCl and 0.0020 mol/L ZnSO₄, Ar flow rate: 73 ml/min, Current: 1400 mA, Anolyte flow rate: 2.2 mL/min

3.1.5 Optimization of ZnSO₄ Concentration in Catholyte Solution

The purpose of using ZnSO₄ in the preparation of catholyte solution was to form a Zn layer on the cathode surface. This Zn layer helps to reduce analyte more easily and also prevents the accumulation of analyte on the cathode surface by desorption of it. As it is seen in the Figure 3.5, the effects of ZnSO₄ concentration between the 0.001 mol/L and 0.02 mol/L concentration were investigated. Although the highest signals were obtained between the 0.005 mol/L and 0.01 mol/L ZnSO₄ concentration range, the lowest concentration of ZnSO₄ that would be sufficient over the cathode surface in order to eliminate the impurities which may come from ZnSO₄. As a result, 0.002 mol/L ZnSO₄ was used in the rest of the studies.

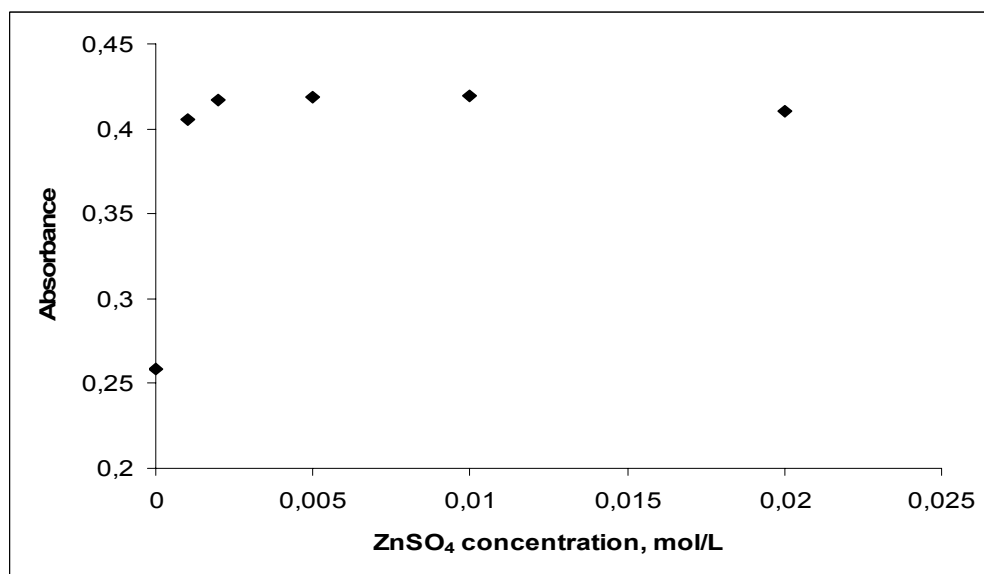

Figure 3.5 Optimization of ZnSO₄ concentration in catholyte solution

Analyte: 4.0 mol/L H₂SO₄, Catholyte: 50 ng/mL Sb in 0.20 mol/L HCl, Ar flow rate: 73 ml/min, Current: 1400 mA, Analyte flow rate: 2.2 mL/min, Cathlyte flow rate: 4.0 mL/min

3.1.6 Optimization of Carrier Gas Flow Rate

Flow rate of carrier gas was one of the fundamental parameters that affect the Sb determination sensitivity. Argon gas was used as carrier gas. Argon was introduced to the system after the catholyte solution has passed from the cathode chamber. It carries the volatile products to the gas-liquid separator. Together with the produced hydrogen gas it also serves for the separation of antimony hydride species from the liquid phase and transport them to the flame heated quartz T-tube atomizer. The effect of change in the gas argon flow rate on the absorbance signal was given in Figure 3.6. The optimum flow rate was determined as 73 mL/min.

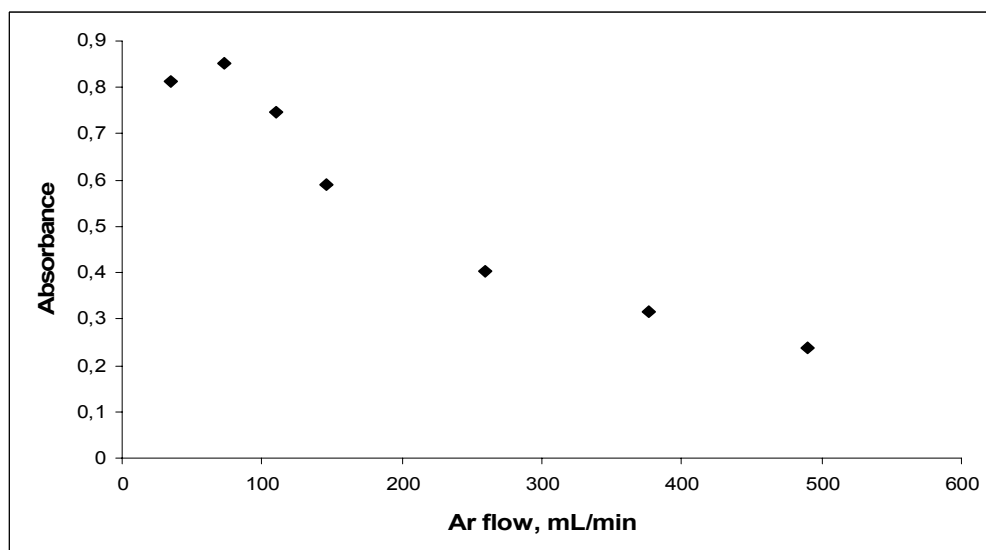

Figure 3.6 Optimization of carrier gas flow rate

Anolyte: 4.0 mol/L H₂SO₄, Catholyte: 100 ng/mL Sb in 0.20 mol/L HCl, Current: 1400 mA, Anolyte flow rate: 2.2 mL/min, Catholyte flow rate: 4.0 mL/min

3.1.7 Effect of Applied Electric Current

The electrochemical antimony hydride generation is highly dependent on the electric current applied to the electrochemical cell. The effect of applied electric current on analytical signal is shown in Figure 3.7. The absorbance signal increased rapidly when the current was increased from 600 mA to 800 mA. When the current was increased furthermore, the signal also increased. However, as the currents higher than 1400 mA could not be applied with the power supply used 1400 mA was selected as the operating current throughout the studies.

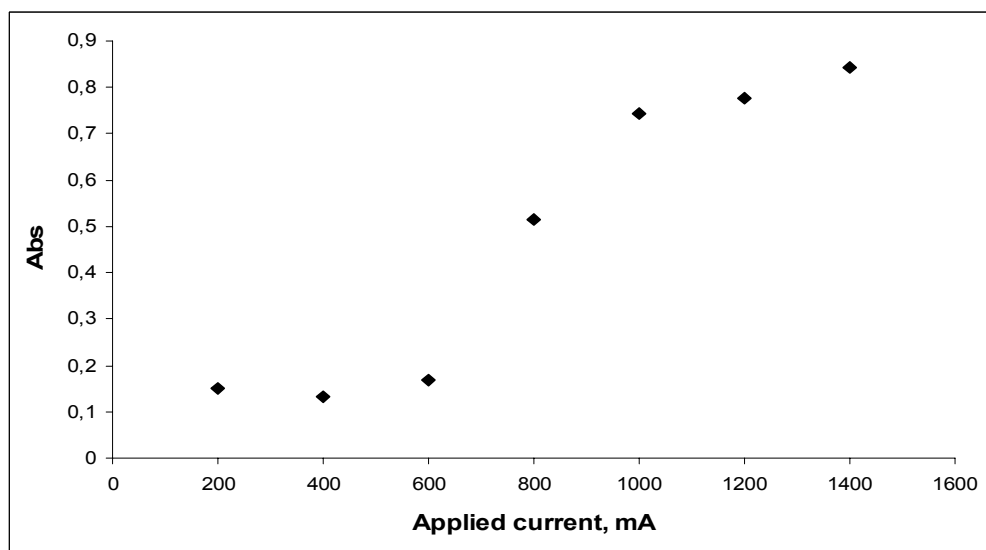

Figure 3.7 Effect of the applied electric current on the absorbance signal

Anolyte: 4.0 mol/L H₂SO₄, Catholyte: 100 ng/mL Sb in 0.20 mol/L HCl and 0.0020 mol/L ZnSO₄, Ar flow rate: 73 mL/min, Anolyte flow rate: 2.2 mL/min, Catholyte flow rate: 4.0 mL/min.

Optimum conditions of electrochemical hydride generation are shown in Table 3.1.

Table 3.1 Optimum Conditions of Electrochemical Hydride Generation

Parameter	
Anolyte	4.0 mol/L H ₂ SO ₄
Catholyte	0.20 mol/L HCl, 0.0020 mol/L ZnSO ₄
Anolyte flow rate	2.2 mL/min
Catholyte flow rate	4.0 mL/min
Ar flow rate	73 mL/min
Applied current	1400 mA

3.2 Analytical Figures of Merit

Under the obtained optimum conditions, Sb standards in 0.2 mol/L HCl and 0.0020 mol/L ZnSO₄ at a concentration interval of 5 - 200 ng/mL were used as the catholyte solutions. The calibration plot for this interval is shown in Figure 3.8. The calibration plot was linear between 5-100 ng/mL; the linear portion is given in Figure 3.9. The best line equation and the correlation coefficient are, $y = 0.0077x + 0.0085$ and 0.9992, respectively.

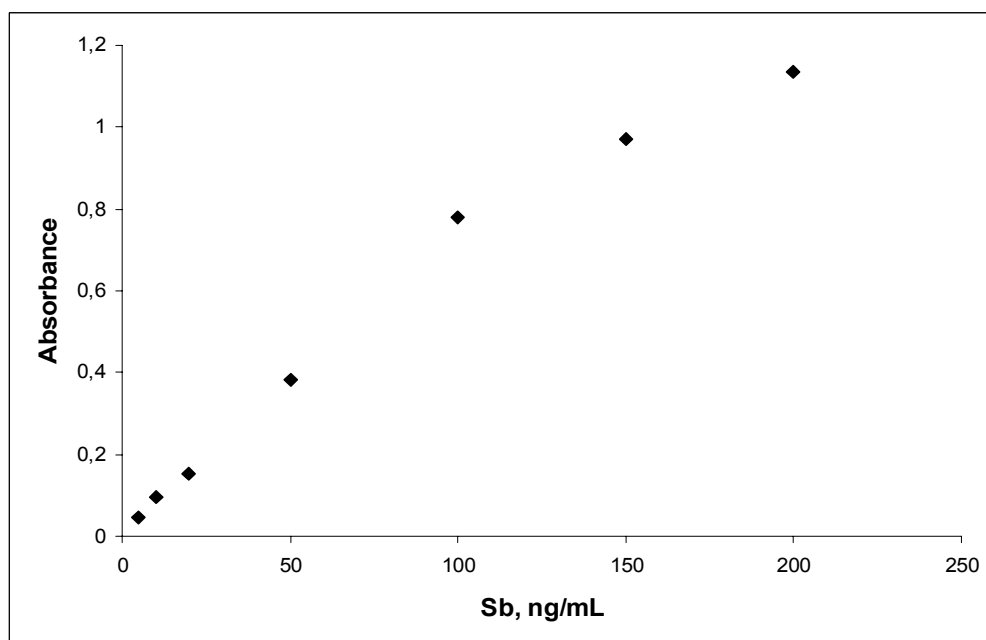

Figure 3.8 Calibration plot for electrochemical hydride generation of Sb. The conditions are given on Table 3.1.

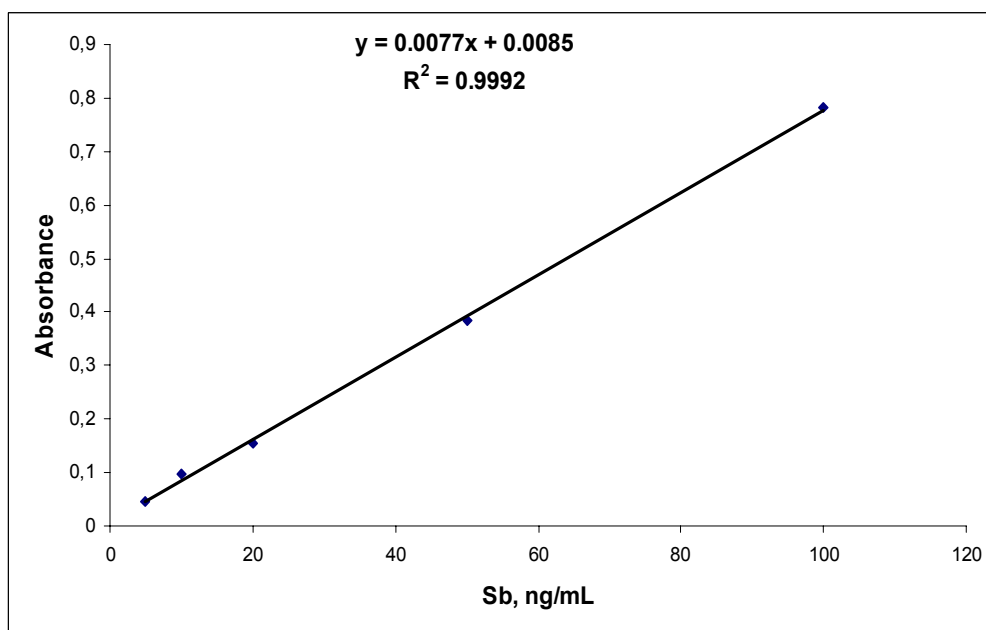

Figure 3.9 Linear calibration plot for electrochemical hydride generation of Sb. The conditions are given on Table 3.1.

The 3σ limit of detection was calculated as 0.41 ng/mL and the characteristic concentration (C_0) for 50 ng/mL Sb was found to be 0.57 ng/mL. Three times the standard deviation of 0.5 ng/mL Sb values was used in the LOD calculation. The relative standard deviation was lower than 5% for electrochemical hydride generation.

3.3 Comparison of Electrochemical Hydride Generation and Chemical Hydride Generation

In order to compare electrochemical hydride generation and chemical hydride generation techniques, the experiments using chemical hydride generation were conducted by the optimum conditions normally used in our

laboratory previously [37]. The optimum conditions for the chemical hydride generation method are given in the Table 3.2. The comparison between electrochemical hydride generation and chemical hydride generation were done in terms of their linear range, 3σ limit of detection (LOD) and characteristic concentration.

Table 3.2 Optimum Conditions for Chemical Hydride Generation Technique

Parameter	
Carrier solution	0.10 mol/L HCl
Reducing solution	1.2 % w/v NaBH ₄ in 0.30 % m/v NaOH
Flow rate of carrier solution	9.0 mL/min
Flow rate of reducing solution	2.2 mL/min
Ar flow rate	75 mL/min
Loop volume	1.0 mL

The calibration plot and linear calibration plot are given in Figure 3.10 and Figure 3.11, respectively.

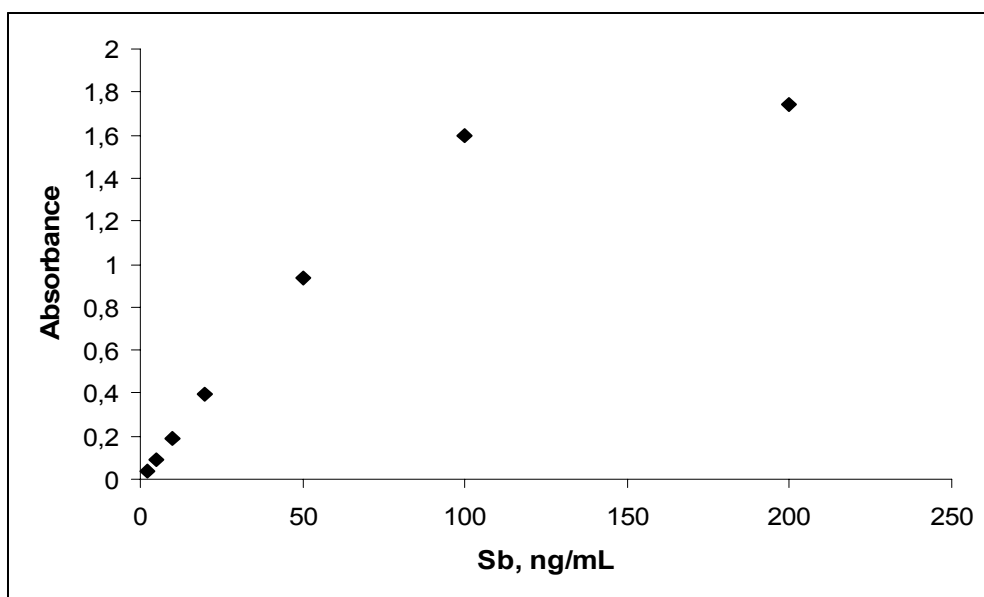

Figure 3.10 Calibration plot of chemical hydride generation of Sb. The conditions are given on Table 3.2.

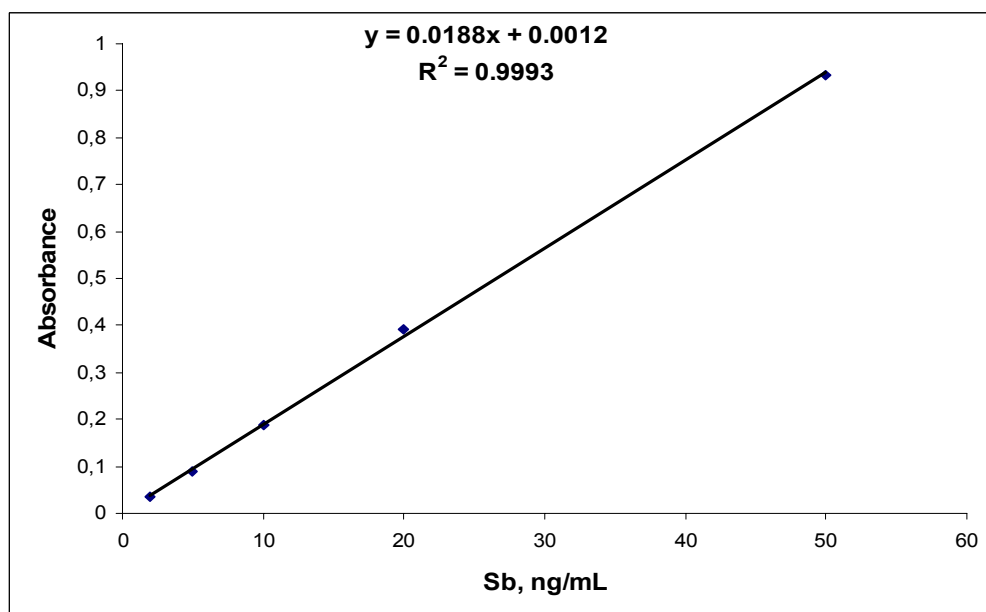

Figure 3.11 Linear calibration plot of chemical hydride generation of Sb. The conditions are given on Table 3.2.

As seen in the Figures 3.9, 3.10 and 3.11, the signals of chemical hydride generation is higher than the signals of electrochemical hydride generation. Linear range of chemical hydride generation was between 2 ng/mL - 50 ng/mL. As seen in Table 3.3, the 3σ limit of detection and characteristic concentration of 50 ng/mL Sb were defined as 0.20 ng/mL and 0.22 ng/mL, respectively.

Table 3.3 Comparison of Electrochemical Hydride Generation and Chemical Hydride Generation Techniques

	Chemical Hydride Generation	Electrochemical Hydride Generation
Best line equation	$y = 0.0188x + 0.0012$	$y = 0.0077x + 0.0085$
LOD (ng/mL)	0.20	0.41
C_0 (ng/mL)	0.22	0.57

3.4 Optimization of W-coil Atom Trapping Conditions for Sb Determination by Electrochemical Hydride Generation

In order to increase the sensitivity, W-coil atom trap was added to the system.

All the optimizations for trapping parameters were done with 20 ng/mL Sb in 0.20 mol/L HCl.

During 2.0 minutes collection period, 73 mL/min Ar and 40 mL/min H₂ gas were sent to the system. During the releasing period, Ar flow rate was not changed but H₂ flow rate was increased up to 350 mL/min. The function of Ar gas was to transport the hydrides which were produced electrochemically

to the W-trap then to the quartz T-tube. The function of H₂ gas was to prevent the oxidation of W-trap during collection and releasing steps. Figure 3.12 shows the Sb signal obtained by using W-trap.

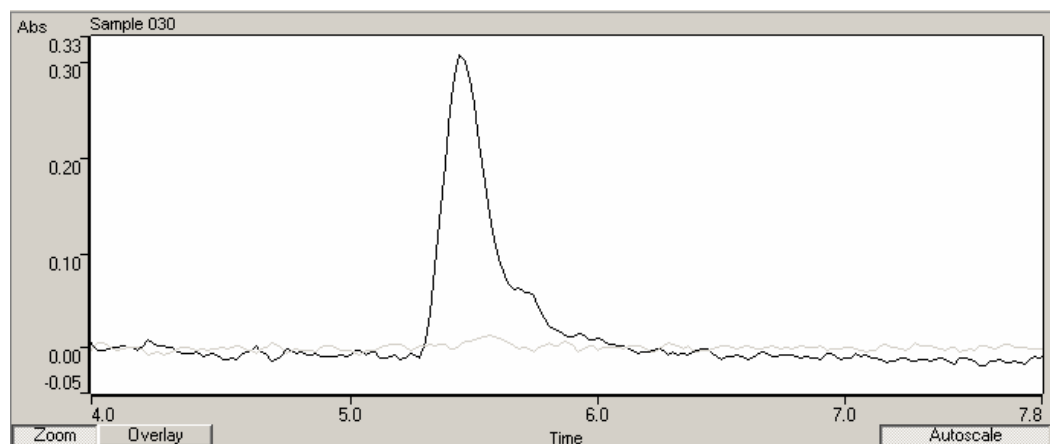

Figure 3.12 Sb signal obtained by W-trap ECHG-AAS

Analyte: 4.0 mol/L H₂SO₄, Catholyte: 20 ng/mL Sb in 0.20 mol/L HCl and 0.0020 mol/L ZnSO₄, Ar flow rate: 73 mL/min, H₂ flow rate during collection: 40 mL/min, H₂ flow rate during releasing: 350 mL/min, Analyte flow rate: 2.2 mL/min, Catholyte flow rate: 4.0 mL/min, Current: 1400 mA, Collection temperature: 570^oC, Releasing temperature: 1480^oC, Collection time: 2.0 min.

After obtaining this signal, W-trap was coated with some metals such as Au, Ti and Ta in order to increase the trapping ability of W-coil. However absorbance signal did not change. When W-trap was coated with Zr, Sb signal was doubled (Figure 3.13). Both of the signals had a half width of approximately 0.2 seconds. Peak heights were used.

To coat W-trap with Zr, 50 μ L 1000 mg/L Zr standard AAS solution was dropped on to the W-trap. W-coil was placed into the trap apparatus and heated up to 800^oC. This procedure was repeated 10 times.

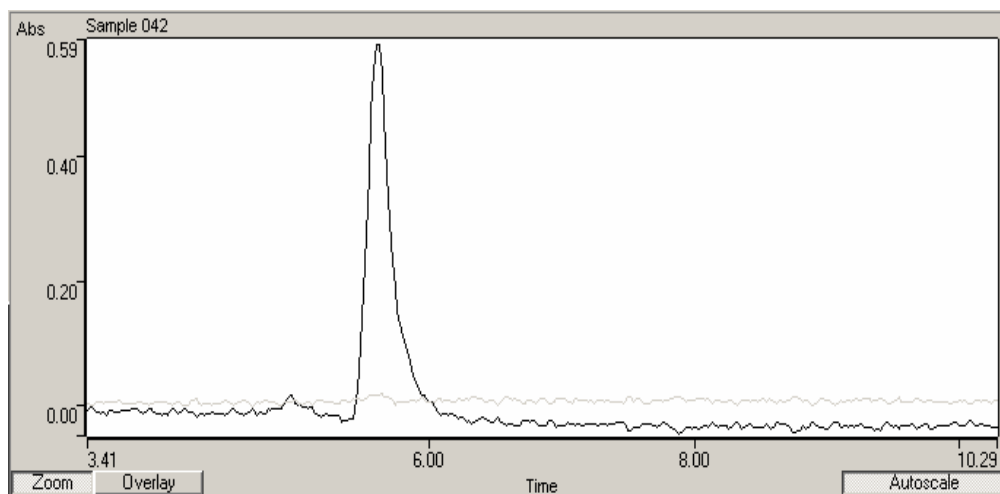

Figure 3.13 Sb signal obtained by Zr coated W-trap ECHG-AAS

Analyte: 4.0 mol/L H₂SO₄, Catholyte: 20 ng/mL Sb in 0.20 mol/L HCl and 0.0020 mol/L ZnSO₄, Ar flow rate: 73 mL/min, H₂ flow rate during collection: 40 mL/min, H₂ flow rate during releasing: 350 mL/min, Analyte flow rate: 2.2 mL/min, Catholyte flow rate: 4.0 mL/min, Current: 1400 mA, Collection temperature: 570 °C, Releasing temperature: 1480 °C, Collection time: 2.0 min.

3.4.1 Optimization of Collection Temperature for Zr coated W Atom Trapping

During the optimization of collection temperature, releasing temperature was kept constant at 1480 °C. The effect of change in the collecting temperature on the Sb signal was given in Figure 3.14. 570 °C was chosen as the optimum collection temperature.

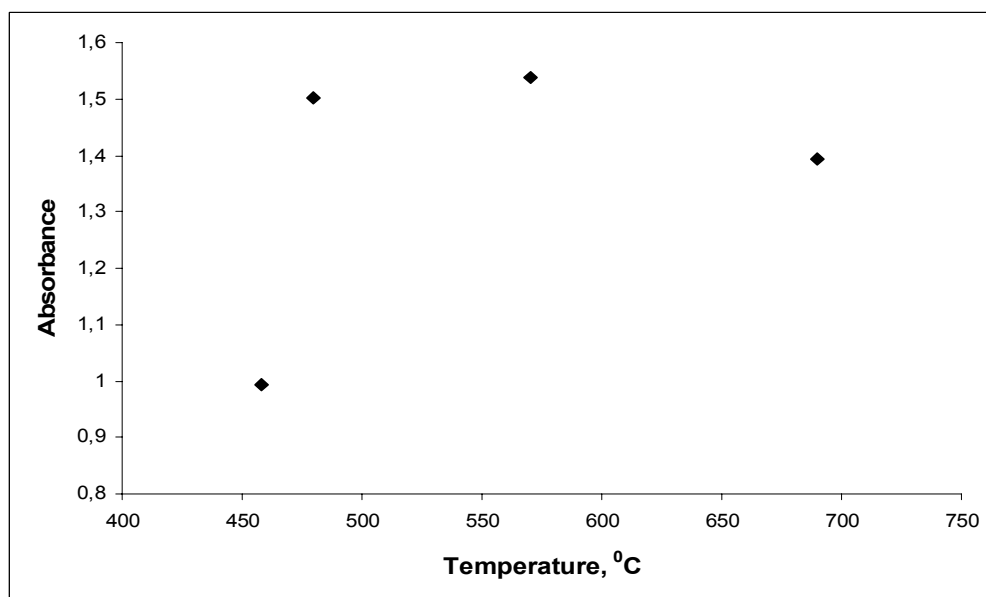

Figure 3.14 Optimization of collection temperature by Zr coated W-trap by ECHG-AAS

Analyte: 4.0 mol/L H₂SO₄, Catholyte: 20 ng/mL Sb in 0.20 mol/L HCl and 0.0020 mol/L ZnSO₄, Flow rate of Ar: 73 mL/min, Flow rate of anolyte: 2.2 mL/min, Flow rate of catholyte: 4.0 mL/min, Current: 1400 mA, Releasing temperature: 1480 °C, Collection time: 300 s, Flow rate of H₂ (collecting): 40 mL/min, Flow rate H₂ (releasing): 250 mL/min.

3.4.2 Optimization of Releasing Temperature for Zr-coated W Atom Trapping

Collection temperature of trapping system was kept constant at 570 °C during the optimization of releasing temperature. Figure 3.15 shows the effect of releasing temperature on Sb signal. The optimum releasing temperature was chosen as 1480 °C.

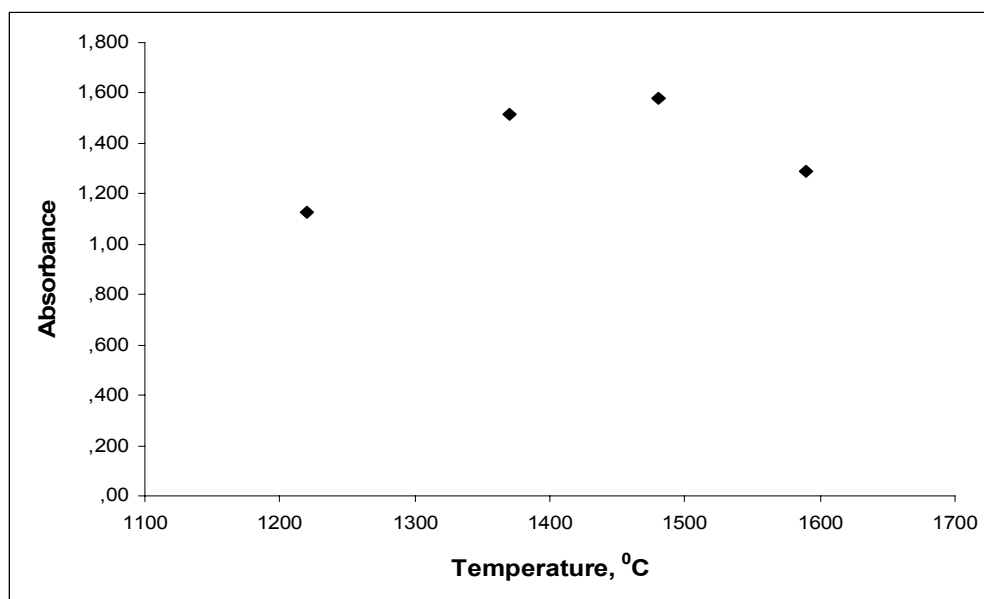

Figure 3.15 Optimization of releasing temperature for Zr coated W-trap by ECHG-AAS

Analyte: 4.0 mol/L H₂SO₄, Catolyte: 20 ng/mL Sb in 0.20 mol/L HCl and 0.0020 mol/L ZnSO₄, Flow rate of Ar: 73 mL/min, Analyte flow rate: 2.2 mL/min, Catholyte flow rate: 4.0 mL/min, Current: 1400 mA, Collecting temperature: 570 °C, Collection time: 300 s, Flow rate of H₂ (collecting): 40 mL/min, Flow rate H₂ (releasing): 250 mL/min.

3.4.3 Effect of Collection Period

Collection period on W-trap was varied between 30-360 seconds. As seen in the Figure 3.16, as the trapping time increases, the absorbance signal also increases. Therefore, 300 second was determined as the optimum value.

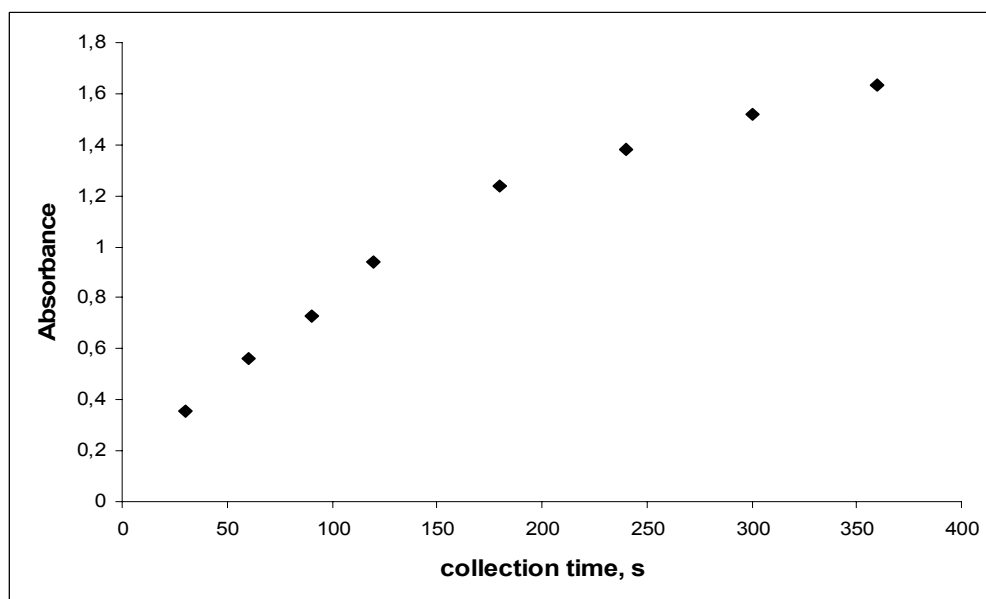

Figure 3.16 Optimization of collection time for Zr coated W-trap by ECHG-AAS

Analyte: 4.0 mol/L H_2SO_4 , Catholyte: 20 ng/mL Sb in 0.20 mol/L HCl and 0.0020 mol/L $ZnSO_4$, Ar flow rate: 73 mL/min, Analyte flow rate: 2.2 ml/min, Catholyte flow rate: 4.0 mL/min, Current: 1400 mA, Collecting temperature: 570 °C, Releasing temperature: 1480 °C, Flow rate of H_2 (collecting): 40 mL/min, Flow rate H_2 (releasing): 250 mL/min.

3.4.4 Optimization of Flow Rate of H_2 During Collection Step

H_2 gas was passed through the system in order to prevent oxidation of W-trap at collection temperature during collection time of analyte on Zr-coated W-trap. Otherwise, W-trap can be oxidized and loses its trapping ability. As seen in the Figure 3.17, the optimum H_2 flow rate during collection stage was found as 40 mL/min.

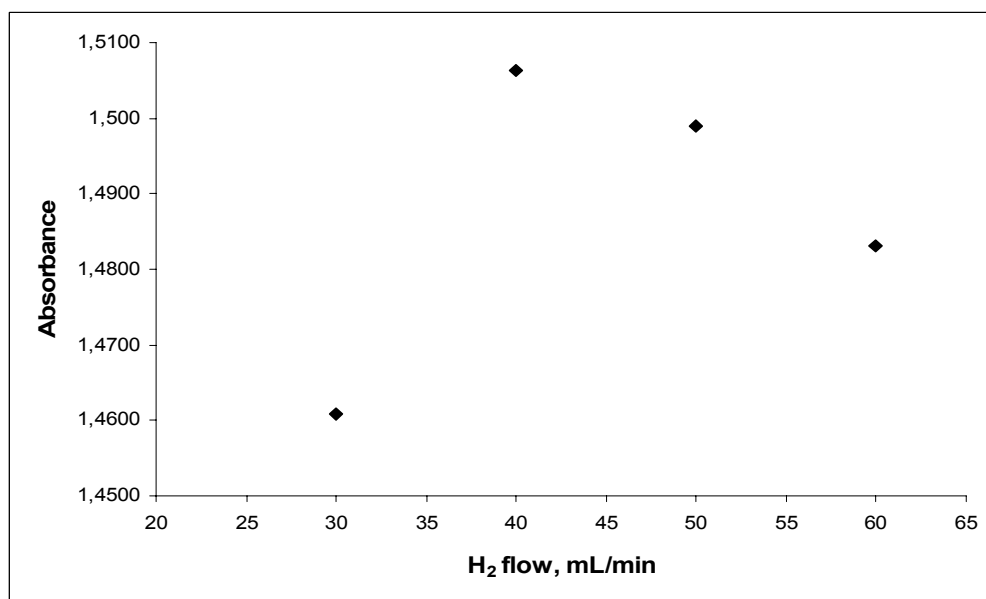

Figure 3.17 Optimization of flow rate of H₂ during collection step for Zr coated W-trap by ECHG-AAS

Analyte: 4.0 mol/L H₂SO₄, Catholyte: 20 ng/mL Sb in 0.20 mol/L HCl and 0.0020 mol/L ZnSO₄, Ar flow rate: 73 mL/min, Analyte flow rate: 2.2 mL/min, Catholyte flow rate: 4.0 mL/min, Current: 1400 mA, Collecting temperature: 570 °C, Collection period: 300 s, Releasing temperature: 1480 °C, Flow rate H₂ (releasing): 250 mL/min.

3.4.5 Optimization of Flow Rate of H₂ During Releasing Step

The trapped analyte on Zr-coated W-trap was released by increasing the voltage applied on the trap. H₂ gas was needed in releasing step of analyte in order to prevent oxidation of W-trap. The optimum flow rate of H₂ gas was found as 250 mL/min as seen in Figure 3.18.

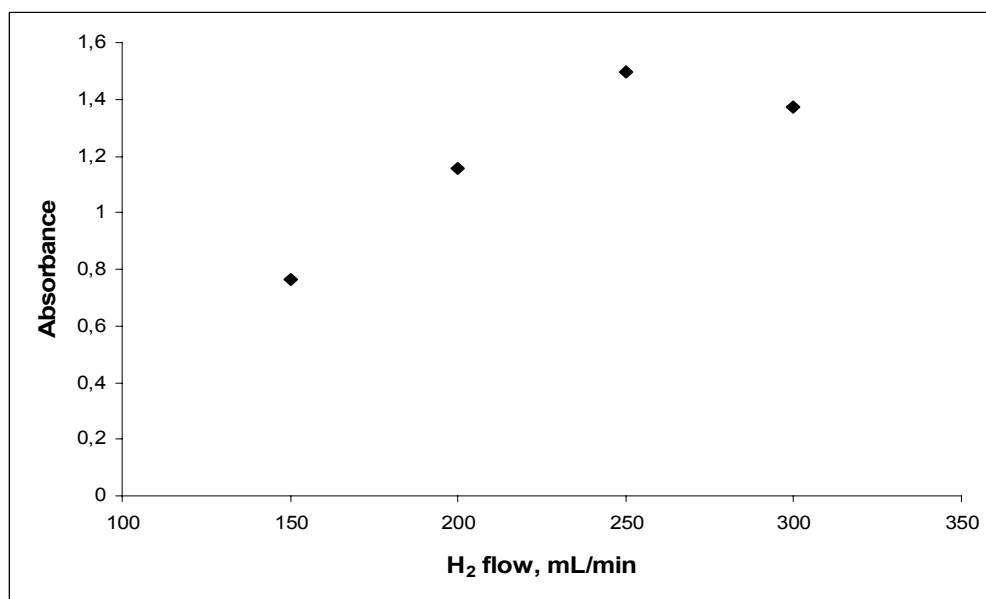

Figure 3.18 Optimization of flow rate of H₂ during releasing step for Zr coated W-trap by ECHG-AAS

Analyte: 4.0 mol/L H₂SO₄, Catholyte: 20 ng/mL Sb in 0.20 mol/L HCl and 0.0020 mol/L ZnSO₄, Ar flow rate: 73 mL/min, Analyte flow rate: 2.2 mL/min, Catholyte flow rate: 4.0 mL/min, Current: 1400 mA, Collecting temperature: 570 °C, Collection period: 300 s, Flow rate H₂ (collecting): 250 mL/min, Releasing temperature: 1480 °C,.

Table 3.4 Optimum conditions of Zr-coated W Trap ECHG

Parameter	
Collection Temperature	570 °C
Releasing Temperature	1480 °C
Collection period	300 s
H ₂ flow during collection	40 mL/min
H ₂ flow during releasing	250 mL/min

3.4.6 Analytical Figures of Merit for Sb Determination Using Zr-coated W-trap by ECHG-AAS

The calibration plot of Zr-coated W-trap ECHG-AAS technique was obtained in the range of 0.5-50 ng/mL Sb in 0.20 mol/L HCl and 0.002 mol/L ZnSO₄ applying the optimum conditions given in Table 3.4 (Figure 3.19).

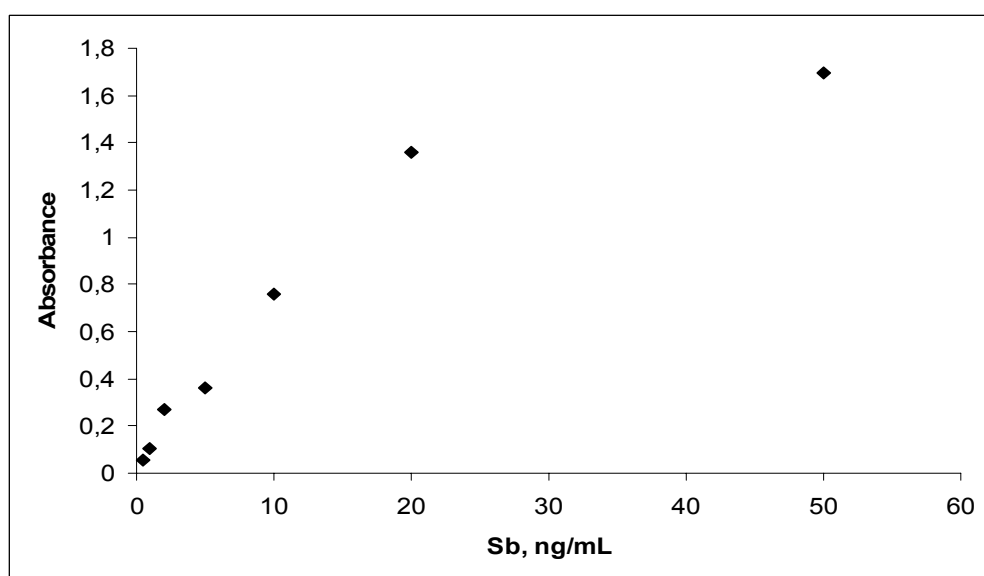

Figure 3.19 Calibration Plot of Zr-coated W-trap ECHG-AAS for Determination of Sb
Optimum conditions are given in Table 3.4.

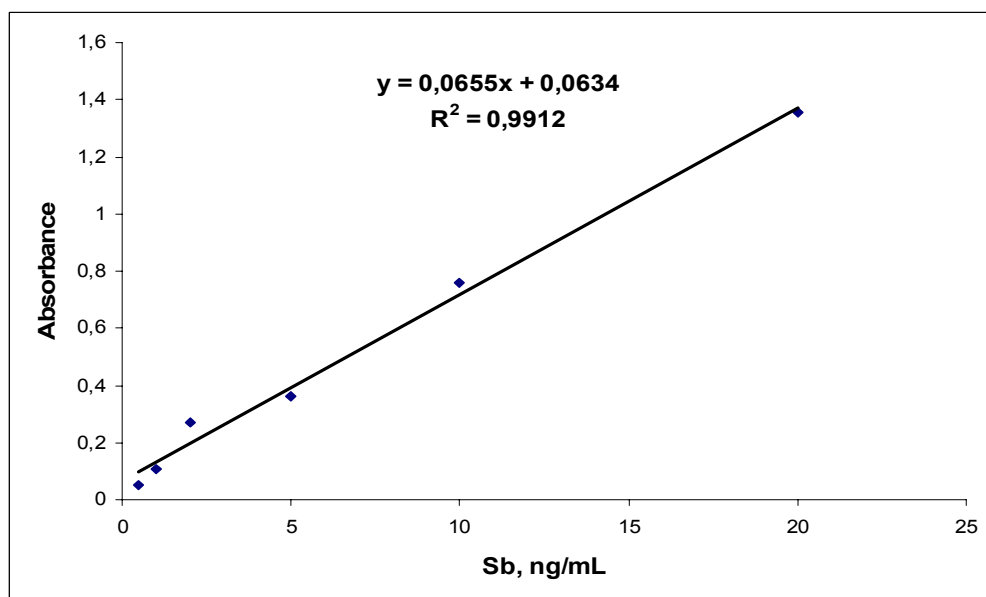

Figure 3.20 Linear Calibration Plot of Zr-coated W-trap ECHG-AAS
Optimum conditions are given in Table 3.4.

As seen in Figure 3.19 and Figure 3.20, it was observed that in lower concentration range of Sb, more effective results could be obtained from Zr-coated W-trap ECHG-AAS. Therefore, the efficiency of Zr-coated W-trap was studied for lower Sb concentration. Throughout this study, the D_2 lamp was turned off since D_2 background signal suppressed the atomic signal. All the Sb absorbance signals obtained were blank corrected results. The calibration plot for low concentration range is given in Figure 3.21.

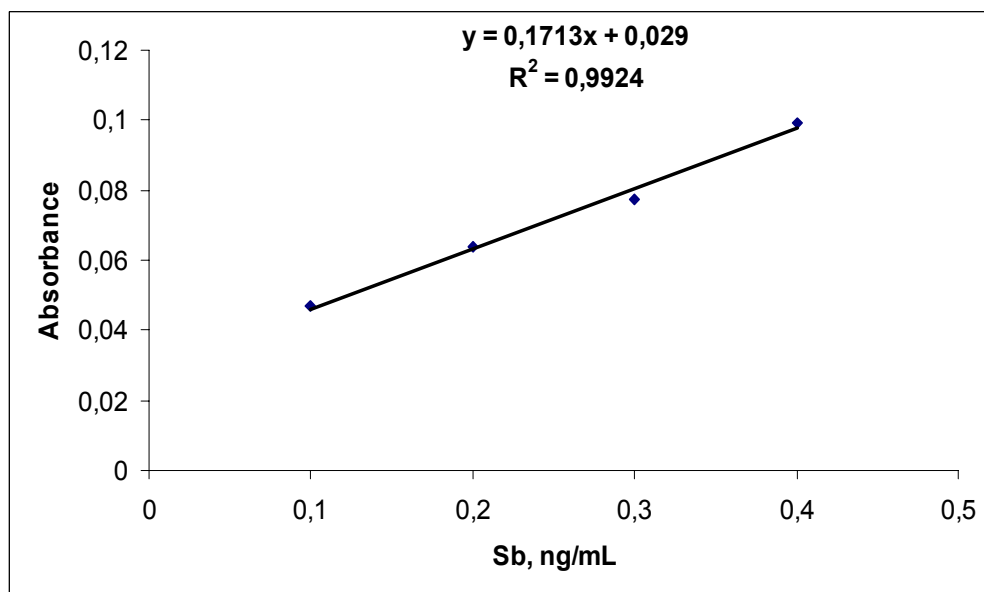

Figure 3.21 Calibration Plot of lower concentration of Zr-coated W-trap ECHG-AAS

Optimum conditions are given in Table 3.4.

3σ limit of detection ($LOD_{3\sigma}$) and characteristic concentration for 0.3 ng/mL Sb (C_0) was calculated as 0.012 ng/mL and 0.017 ng/mL, respectively.

3.5 Discussion of System Performance and Comparison with Similar Studies

As seen in Table 3.5, beside determining the C_0 and LOD values, normalization is also done according to the total time and the total volume for atom trapping as mentioned in a recent study [2]. Enhancement factor (E) values in this table have been calculated by taking the ratio of characteristic concentration values. In other words, E value is the ratio of calibration sensitivities (slope). A higher E value shows the enhancement of sensitivity

that is the improvement by using the new technique. However, in order to normalize the results for different time durations and sample volumes for different cases, E_t and E_v values are calculated by division of E value to total time in terms of minute unit, and E value to total sample volume in terms of mL unit, respectively. Zr-coated W-trap ECHG-AAS technique is then easily compared with other techniques present in Table 3.5 in terms of either characteristic concentration or limit of detection. Zr-coated W-trap ECHG-AAS technique which has the best limit of detection in the Table 3.5 is also in the second order in terms of E_t and E_v values.

Table 3.5 Comparison of Sb Determination by ECHG in Similar Studies Regarding Characteristic Concentration, C_0 ; Limit of Detection, LOD_{3s} , Enhancement Factor of Trap, E

Technique, Period, Volume	C_0 , ng/mL	LOD , ng/mL	E	E_t , min ⁻¹	E_v , mL ⁻¹	Reference
CHG-AAS, W-trap, 4.0 min, 36 mL	0.026	0.016	17*	4.25	0.47	37
ECHG-AAS, Quartz-Trap, 2.0 min, 6.0 mL	0.044	0.053	18**	9.0	3.0	34
ECHG-AAS	0.57	0.41	1	--	--	This Study
ECHG-AAS, W trap, 2.0 min, 8.0 mL	~0.26	--	2.2	1.1	0.28	This Study
ECHG-AAS, Zr-W trap, 5.0 min, 20 mL	0.017	0.012	33.5	6.7	1.68	This Study

* E=1 for CHG-AAS

** E=1 for ECHG-AAS

As a result, the developed analytical technique provides a sensitive determination of Sb in ng/mL level; for this purpose only a flame AA spectrometer and a simple laboratory set up had been used. In addition the method suggested is very economical.

3.6 Determination of Sb (III) and Sb (V) without and with Zr-coated W Trap

The signals for the two oxidation states of Sb were taken first by electrochemical hydride generation and then Zr-coated W trap electrochemical hydride generation techniques. It was found that the results were identical. The hydrides generated from Sb (III) and Sb (V) solutions were collected in the trap and it was investigated whether the efficiency of the trap was the same for this oxidation state of the analyte. The signals identical to the ones obtained with collection of Sb (III) were obtained. This indicates that the efficiency of the trap is same for both of the oxidation states.

3.7 Interference Studies

During the interference studies, standards at concentrations of 50 and 20 ng/mL Sb in 0.2 mol/L HCl and 0.002 mol/L ZnSO₄ were used together with interferents for without trap and with trap experiments respectively. The interferent concentrations were 1, 10, 100 and 1000 folds of the Sb concentrations.

Oxidation states of interferents are given below.

Arsenic: H_3AsO_4 in 0.5 mol/L HNO_3 , As(V)

Selenium: Se metal in dilute HNO_3 , Se(VI)

Lead: Pb metal in dilute HNO_3 , Pb^{2+}

Tin: SnCl_4 in 2.0 mol/L HCl , Sn^{4+}

Iron: $\text{Fe}(\text{NO}_3)_3$ in 0.5 mol/L $\text{HNO}_3 \rightarrow \text{Fe}^{3+}$

Cobalt: Co metal in dilute $\text{HNO}_3 \rightarrow \text{Co}^{2+}$

Copper: $\text{Cu}(\text{NO}_3)_2$ in 0.5 mol/L HNO_3 , Cu^{2+}

Nickel: Ni metal in dilute $\text{HNO}_3 \rightarrow \text{Ni}^{2+}$

Figure 3.22 and 3.23 are the graphical representations of the interference effects of arsenic, selenium, tin and lead on the absorbance signals of Sb without trap and with trap respectively.

As it can be seen from Figure 3.22, the presence of 50 ng/mL selenium did not affect the antimony signal too much but the presence of ten fold selenium resulted in 20% increase. When the selenium amount was increased to 100 fold of analyte concentration, Sb signal stayed constant at 120%. The presence of 1000 fold selenium decreased the Sb signal from 120% to 110%. In the presence of arsenic, the signals increased by 14%, 33% and 54% at arsenic concentrations that are 1, 10 and 100 folds respectively. When the arsenic concentration was increased to 1000 folds of analyte, Sb signal stayed constant at 154%. In the presence of 50 ng/mL lead and tin, Sb signal decreased by 38%. When the lead concentration increased to 10 and 100 folds of analyte, antimony signal increased to 117%

and 147% respectively and the presence of 1000 folds tin increased the signal 20%.

As it is seen in the Figure 3.23, Zr-coated W trap eliminated the interference effect of arsenic on antimony signal at the concentration of 200 ng/mL with respect to the ECHG without trap. On the contrary, at the higher concentration of arsenic, trap suppressed the antimony signal by 10% to 35%. Similar to arsenic, at the concentration of 200 ng/mL, trap eliminated the interference effect of selenium on antimony signal. In the presence of approximately 50 ng/mL of lead, trap eliminated the 30% suppression of Sb signal which was observed in ECHG without trap. Zr-coated W trap eliminated the interference effect of Sn at the concentration of 1000 ng/mL with respect to the ECHG without trap.

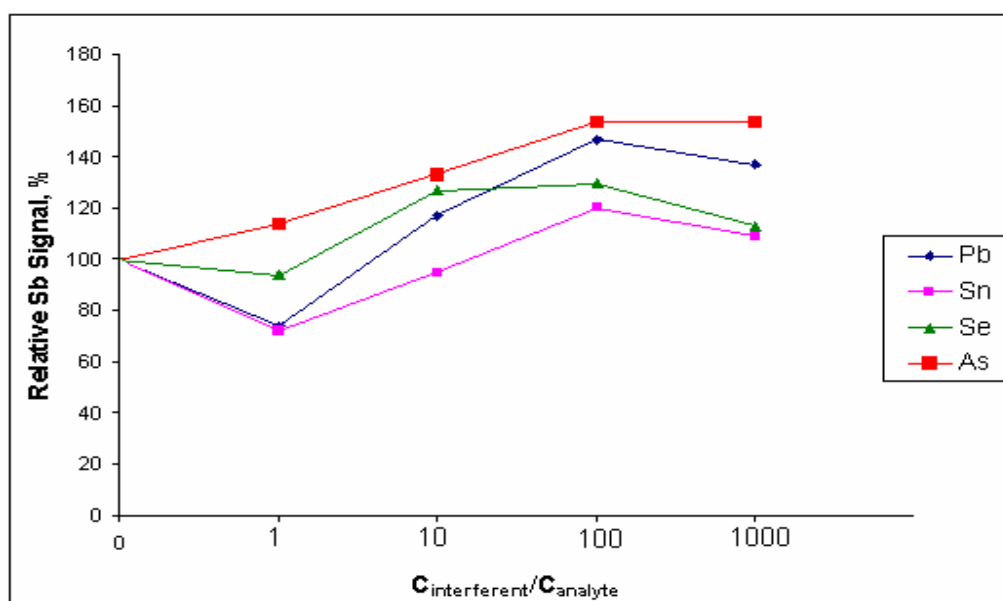

Figure 3.22 Interference of arsenic, selenium, tin and lead on electrochemical hydride generation without trap; 50 ng/mL Sb.

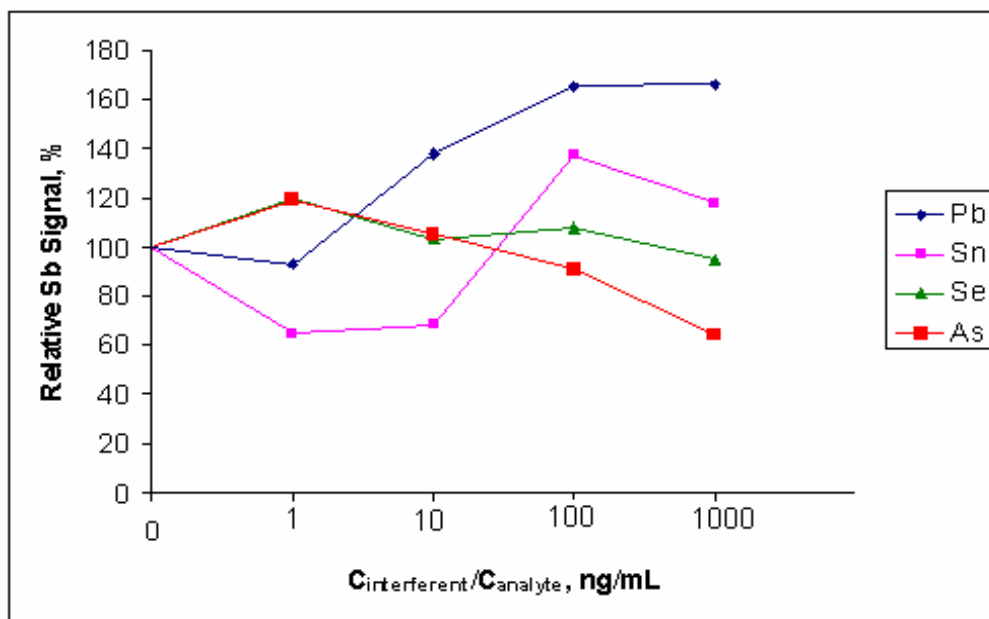

Figure 3.23 Interference of arsenic, selenium, tin and lead on electrochemical hydride generation with trap; 20 ng/mL Sb.

As it is seen in the Figure 3.24, interference effects of cobalt and copper were similar to each other. In the presence of 500 ng/mL cobalt and copper increased the antimony signal by 12% and 17%, respectively. On the other hand, antimony signal decreased up to approximately 40% as iron and nickel concentrations were increased.

As shown in Figure 3.25, Zr-coated W trap does not have any considerable advantage on the elimination of the interference effects of iron, cobalt, copper and nickel.

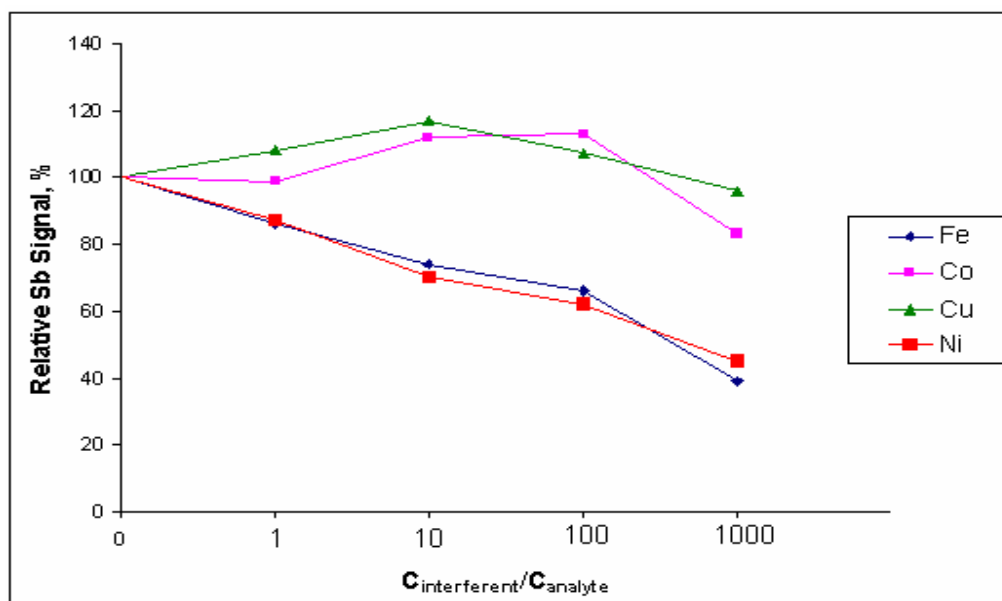

Figure 3.24 Interference of iron, cobalt, copper and nickel on electrochemical hydride generation without trap; 50 ng/mL Sb.

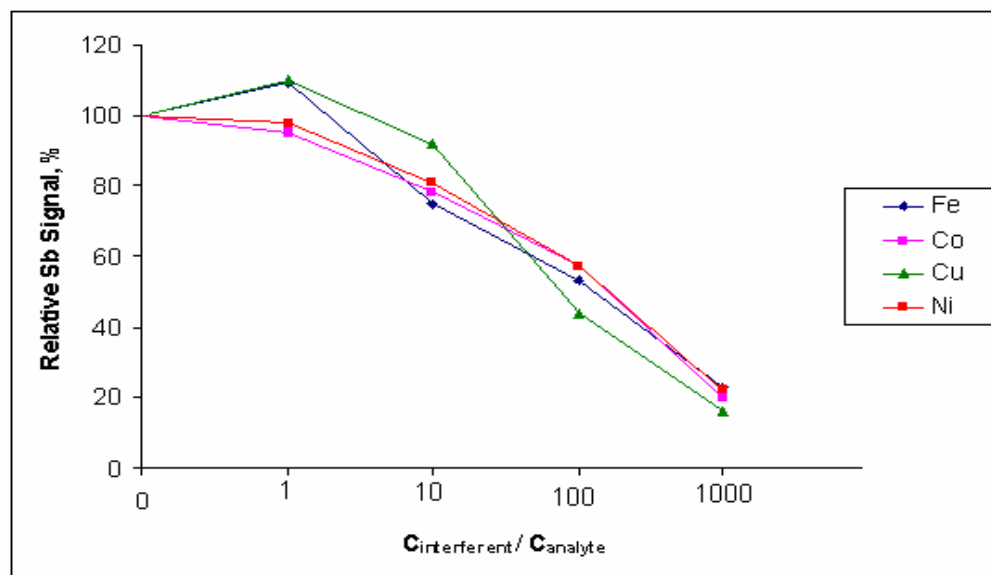

Figure 3.25 Interference of iron, cobalt, copper and nickel on electrochemical hydride generation with trap; 20 ng/mL Sb.

3.8 Analysis of Standard Reference Material

Table 3.5 gives the certified and found value for the standard reference material (SRM). The amount of Sb in SRM was found to be in good agreement with the certified value

Table 3.6 Results of the analysis of standard reference material

SRM	Certified Value	Found
SRM 2710, mg/kg	38.4 ± 3	37.3 ± 1.9

CHAPTER 4

CONCLUSIONS

Electrochemical hydride generation of antimony and trapping the generated hydrides on surface of Zr-coated W-coil were studied. Throughout the studies, Zn coated spectral grade carbon rod and platinum foil were used as cathode and anode materials, respectively. Cleaning of cathode surface was done without disassembling the electrolytic cell. The experimental operation parameters in electrochemical hydride generation were optimized. Employing the electrochemical hydride generation technique, 3σ detection limit and characteristic concentration values were calculated as 0.41 ng/mL and 0.57 ng/mL, respectively.

Determination of the two oxidation states of Sb (Sb(III) and Sb(V)) was performed and it was concluded that by employing spectral grade carbon rod as cathode material, hydrides of both of the oxidation states were generated with the same efficiency, which is an advantage for total antimony determination for real samples. Speciation can be performed with the electrochemical hydride generation technique by choosing the cathode material according to its influence on the efficiency of hydride generation which depends on the analyte oxidation state.

Electrically heated Zr-coated W-coil surface was used as atom trap. The trap parameters were optimized and 3σ detection limit and characteristic concentration values were found to be 0.012 ng/mL and 0.017 ng/mL,

respectively. The results show that the Zr-coated W-trap improves the sensitivity approximately 34 fold with respect to electrochemical hydride generation technique.

The interferences of some hydride forming elements and some transition metals on electrochemical hydride generation with and without employing the trap were investigated.

Accuracy of the system was checked with the analysis of SRM. The amount of Sb in SRM was found to be in good agreement with the certified value.

REFERENCES

- [1] A. Walsh, "The Application of Atomic Absorption Spectra to Chemical Analysis", *Spectrochim. Acta*, 1955, 7, 108.
- [2] O. Y. Ataman, "Vapor Generation and Atom Traps: Atomic Absorption Spectrometry at the ng/L Level", *Spectrochim. Acta Part B*, 2008, 63, 825.
- [3] R. J. Watling, "The Use of a Slotted Quartz Tube for the Determination of As, Sb, Se and Hg", *Anal. Chim. Acta*, 1977, 94, 181.
- [4] R. J. Watling, "The use of a Slotted Tube for the Determination of Lead, Zing, Cadmium, Bismuth, Cobalt, Manganese and Silver by Atomic Absorption Spectrometry", *Anal. Chim. Acta*, 1978, 97, 395.
- [5] G. Huang, S. Qian and H. Yang, "Study of Slotted Quartz Tube Atom Trapping Atomic Absorption Spectrometry", *Ziran Kexueban Hua Xue Fen Xi*, 1995, 41, 707.
- [6] C. M. Lau, A. Held and R. Stephens, "Sensitivity Enhancements to Flame AAS by Use of a Flame Atom Trap", *Can. J. Spectroscopy*, 1976, 21, 100.
- [7] C. M. Lau, A. M. Ure and T. S. West, "The Determination of Lead and Cadmium in Soils by Atom Trapping Atomic Absorption Spectrometry", *Anal. Chim. Acta*, 1983, 146, 171.

[8] J. Khalighie, A. M. Ure and T. S. West, "Atom Trapping Atomic Absorption Spectrometry of Arsenic, Cadmium, Lead, Selenium and Zinc in Air-Acetylene and Air-Propane Flames", *Anal. Chim. Acta*, 1981, 131, 27.

[9] N. Ertaş, Atom Trapping Atomic Absorption Spectrometry Using Silica and Metal Tubes, M. Sc. Thesis, METU, 1990.

[10] H. Matusiewicz and M. Kopras, "Methods for Improving the Sensitivity in Atom Trapping Flame Absorption Spectrometry: Analytical Scheme for the Direct Determination of Trace Elements in Beer", *J. Anal. At. Spectrom.*, 1997, 12, 1287.

[11] A. D. Campell, "A Critical Survey of Hydride Generation Techniques in Atomic Spectroscopy", *Pure & Appl. Chem.*, 1992, 64, 227.

[12] W. Holak, "Gas-sampling Technique for Arsenic Determination by Atomic Absorption Spectrometry", *Anal. Chem.*, 1969, 41, 1712.

[13] D. K. Korkmaz, N. Ertaş, O. Y. Ataman, "A Novel Silica Trap for Lead Determination by Hydride Generation Atomic Absorption Spectrometry", *Spectrochim. Acta Part B*, 2002, 57, 571.

[14] O. Cankur, N. Ertaş, O. Y. Ataman, "Determination of Bismuth Using On-line Preconcentration by Trapping on Resistively Heated W Coil and Hydride Generation Atomic Absorption Spectrometry", *J. Anal. At. Spectrom.*, 2002, 17, 603.

- [15] İ. Kula, Y. Arslan, S. Bakırdere, O. Y. Ataman, "A Novel Analytical System Involving Hydride Generation and Gold-Coated W-Coil Trapping Atomic Absorption Spectrometry for Selenium Determination at ng/L level", *Spectrochim. Acta Part B*, 2008, 63, 856.
- [16] E. Denkhaus, A. Golloch, X. M. Guo and B. Huang, "Electrolytic Hydride Generation (EC-HG)-A Sample Introduction System with Some Special Features", *J. Anal. At. Spectrom.*, 2001, 16, 870.
- [17] V. L. Rigin, "Dispersionless AF Determination of As in Biological Materials", *Zh. Anal. Khim.*, 1978, 33, 1966.
- [18] A. Brockmann, C. Nonn and A. Golloch, "New Concept for Hydride Generation Technique: Electrochemical Hydride Generation", *J. Anal. At. Spectrom.*, 1993, 8, 397.
- [19] Y. Lin, X. Wang, D. Yuan, P. Yang, B. Huang and Z. Zhuang, "Flow Injection-Electrochemical Hydride Generation Technique for Atomic Absorption Spectrometry", *J. Anal. At. Spectrom.*, 1992, 7, 287.
- [20] F. Laborda, E. Bolea and J. R. Castillo, "Comment on 'Electrolytic Hydride Generation (EC-HG)-A Sample Introduction System with Some Special Features' by E. Denkhaus, A. Golloch, X.-M. Guo and B. Huang, *J. Anal. At. Spectrom.*, 2001, 16, 870", *J. Anal. At. Spectrom.*, 2002, 17, 727.
- [21] F. Laborda, E. Bolea, M. T. Baranguan and J. R. Castillo, "Hydride Generation in Analytical Chemistry and Nascent Hydrogen: When Is It Going to Be Over?", *Spectrochim. Acta, Part B*, 2002, 57, 797.

[22] E. Bolea, F. Laborda, M. A. Belarra, J. R. Castillo, "Interferences in Electrochemical Hydride Generation of Hydrogen Selenide", *Spectrochim. Acta, Part B*, 2001, 56, 2347.

[23] F. D. Pierce, H. R. Brown. "Inorganic Interference Study of Automated As and Se Determination with AAS", *Anal. Chem.*, 1976, 48, 693.

[24] A. Meyer, Ch. Hofer, G. Toelg, S. Raptis, G. Knapp, "Cross-interferences by Elements in the Determination of Traces of Se by the Hydride AAS procedure", *Fresenius Z. Anal. Chem.*, 1979, 296, 337.

[25] B. Welz, M. Melcher, Mutual Interactions of Elements in the Hydride Technique in AAS. Part 1. Influence of Se on As Determination", *Anal. Chim. Acta*, 1981, 131, 17.

[26] A. E. Smith, "Interferences in the Determination of Elements That Form Volatile Hydrides with Na Borohydride Using AA spectrophotometry and the Ar-H Flame", *Analyst*, 1975, 100, 300.

[27] W. W. Ding, R. E. Sturgeon, "Interference of Copper and Nickel on Electrochemical Hydride Generation", *J. Anal. At. Spectrom.*, 1996, 11, 421.

[28] M. Fiella, N. Belzile, Y. W. Chen, "Antimony in the Environment: A Review Focused on Natural Waters I. Occurrence", *Earth-Science Reviews*, 2002, 57, 15.

[29] P. Smichowski, Y. Madrid, C. Cámara, "Analytical Methods for Antimony Speciation in Waters at Trace and Ultratrace Levels. A Review", *Fresenius J. Anal. Chem.*, 1998, 360, 623.

[30] R. S. Braman, L. L. Justen and C. C. Foreback, "Direct volatilization-spectral emission type Detection System for ng Amounts of As and Sb", *Anal. Chem.*, 1972, 44, 2195.

[31] F. J. Fernández, "AA Determination of Gaseous Hydrides Utilizing Na borohydride reduction", *At. Absorpt Newsl.*, 1973, 12, 93.

[32] W. W. Ding, R. E. Sturgeon, "Evaluation of Electrochemical Hydride Generation for the Determination of Total Antimony in Natural Waters by Electrothermal Atomic Absorption Spectrometry with In Situ Concentration", *J. Anal. At. Spectrom.*, 1996, 11, 225.

[33] F. Laborda, E. Bolea and J. R. Castillo, "Tubular Electrolytic Hydride Generator for Continuous and Flow Injection Sample Introduction System in Atomic Absorption Spectrometry", *J. Anal. At. Spectrom.*, 2000, 15, 103.

[34] İ. Menemenlioğlu, D. Korkmaz, O. Y. Ataman, "Determination of Antimony by Using a Quartz Atom Trap and Electrochemical Hydride Generation Atomic Absorption Spectrometry", *Spectrochim. Acta Part B*, 2007, 62, 40.

[35] N. H. Bings, Z. Stefánka and S. R. Mallada, "Flow Injection Electrochemical Hydride Generation Inductively Coupled Plasma Time-of-Flight Mass Spectrometry for the Simultaneous Determination of Hydride Forming Elements and Its Application to the Analysis of Fresh Water Samples", *Anal. Chim. Acta*, 2003, 479, 203.

[36] M. Hashemi, M. H. Arab-Zavar, A. Sarafraz-Yazdi, "Effect of Cathodic Electrolyte on the Performance of Electrochemical Hydride Generation From Graphite Cathode", *Talanta*, 2004, 64, 644.

[37] S. Titretir, E. Kendüzler, Y. Arslan, İ. Kula, S. Bakirdere, O. Y. Ataman, "Determination of Antimony by Using Tungsten Trap Atomic Absorption Spectrometry", *Spectrochim. Acta Part B*, 2008, 63, 875.