

DISPLAYING THE BODY:
ANATOMY MUSEUM AND ANATOMICAL EXPRESSIONS IN
ARCHITECTURE

A THESIS SUBMITTED TO
THE GRADUATE SCHOOL OF NATURAL AND APPLIED SCIENCES
OF
MIDDLE EAST TECHNICAL UNIVERSITY

BY

ZEYNEP ECE ŞAHİN

IN PARTIAL FULFILLMENT OF THE REQUIREMENTS
FOR
THE DEGREE OF MASTER OF ARCHITECTURE
IN
ARCHITECTURE

SEPTEMBER 2020

Approval of the thesis:

**DISPLAYING THE BODY: ANATOMY MUSEUM AND ANATOMICAL
EXPRESSIONS IN ARCHITECTURE**

submitted by **ZEYNEP ECE ŞAHİN** in partial fulfillment of the requirements for
the degree of **Master of Architecture in Architecture Department, Middle East
Technical University** by,

Prof. Dr. Halil Kalıpçılar
Dean, Graduate School of **Natural and Applied Sciences**

Prof. Dr. Fatma Cânâ Bilsel
Head of the Department, **Architecture, METU**

Prof. Dr. Ayşen Savaş
Supervisor, **Architecture, METU**

Examining Committee Members:

Assist. Prof. Dr. Pelin Yoncacı Arslan
Architecture, METU

Prof. Dr. Ayşen Savaş
Architecture, METU

Prof. Dr. Esin Boyacıoğlu
Architecture, Gazi University

Date: 24.09.2020

I hereby declare that all information in this document has been obtained and presented in accordance with academic rules and ethical conduct. I also declare that, as required by these rules and conduct, I have fully cited and referenced all material and results that are not original to this work.

Name, Last name : Zeynep Ece Şahin

Signature :

ABSTRACT

DISPLAYING THE BODY: ANATOMY MUSEUM AND ANATOMICAL EXPRESSIONS IN ARCHITECTURE

Şahin, Zeynep Ece
Master of Architecture, Architecture
Supervisor: Prof. Dr. Ayşen Savaş

September 2020, 403 pages

Throughout history, architecture and the human body have always been in close contact, affecting, shaping, and altering each other by multifarious means. Just as the human body has been employed as a reference and source of inspiration in architectural practice and theory, the body has also been studied, represented, and communicated in architectural terms. Within this context, going beyond the clichéd body-based analogies in architectural discipline, this study draws attention to the reciprocity of the relations between architecture and the human body and analyzes these relations varying in a wide spectrum from conceptual to practical, from a point of view that focuses on the specific concept of “anatomical display”. With the aim of providing a comprehensive understanding on this particular subject, the spaces of anatomical display; visualization and display methods of anatomical objects; and anatomical structure of the human body are analyzed in detail. The “medical gaze” introduced by Michel Foucault in terms of providing a model of perception that has both medical and spatial quality and emphasizing the powerful connection between “seeing and knowing” is a significant concept for this study. In the light of this concept, the emergence and development processes of anatomy museums and

anatomical theatres and their relation and contribution to the fields of museum and theatre architecture, in general, are examined. Following this research, the relations between architecture, and body are established through the concepts of harmony, space, transparency, cutting and fragmentation. These seemingly simple, yet intrinsically complex concepts are discussed together with binary oppositions such as visible-invisible; transparency-opacity; part-whole, and interior-exterior and explored in different scales and contexts that are mainly, the space of the anatomy museum; the space of the human body; and architectural and theory and practice in a broader sense. Within the theme of “fragments”, “dismembering and remembering” is analyzed and defined as a seminal process that takes place in the space of anatomy museum. The idea of “display in fragments” that has been widely employed in anatomical displays, is presented as a new and inspiring method for the display of architecture. The exhibition “Elements of Architecture”, curated by Rem Koolhaas for the 14th Venice Architecture Biennale is examined within this context.

Keywords: Anatomy Museum, Anatomical Theatre, Anatomical Display, Display of Architecture, Display in Fragments

ÖZ

BEDENİ SERGİLEMEK: ANATOMİ MÜZESİ VE MİMARİDE ANATOMİK İFADELER

Şahin, Zeynep Ece
Yüksek Lisans, Mimarlık
Tez Danışmanı: Prof. Dr. Ayşen Savaş

Eylül 2020, 403 sayfa

Tarih boyunca, mimari ve insan bedeni her zaman yakın temas halinde olmuş, birbirini etkilemiş, şekillendirmiş ve çok çeşitli yollarla değiştirmiştir. İnsan bedeninin mimari pratikte ve teoride bir referans ve ilham kaynağı olarak kullanılması gibi, beden de mimari terimlerle incelenmiş, temsil edilmiş ve iletilmiştir. Bu bağlamda, mimari disiplinde klişeleşmiş beden temelli analogilerin ötesine geçen bu çalışma, mimarlık ile insan bedeni arasındaki ilişkilerin karşılıklılığına dikkat çekerek ve kavramsaldan pratiğe geniş bir yelpazede değişen bu ilişkileri, "anatomik sergileme" kavramı özelinde inceler. Bu spesifik konu hakkında kapsamlı bir anlayış sağlamak amacıyla anatomik sergi alanları; anatomik nesnelerin görselleştirme ve temsil yöntemleri ve insan bedeninin anatomik yapısı detaylı bir şekilde analiz edilmiştir. Michel Foucault'nun ortaya koyduğu "tıbbi bakış" hem tıbbi hem de mekânsal niteliğe sahip bir algı modeli sunması ve "görmek ve bilmek" arasındaki güçlü bağlantıyı vurgulaması açısından bu çalışma için önem taşır. Bu kavram göz önünde bulundurularak, anatomi müzeleri ve anatomi tiyatrolarının ortaya çıkış ve gelişme süreçleri ve bunların daha genel bir çerçevede müze ve tiyatro mimarisiyle kurdukları ilişkiler ve bu alanlara katkıları incelenir. Bu

araştırmanın ardından uyum, mekan, şeffaflık, kesme ve parçalama kavramları üzerinden mimarlık ve beden arasında çeşitli ilişkiler kurulur. Görünüşte basit, ancak doğası gereği karmaşık olan bu kavramlar, görünür-görünmez; şeffaflık-opaklık; parça-bütün ve iç-dış gibi ikili karşıtlıklarla birlikte tartışılır ve anatomi müzesinin mekanı; insan bedeninin mekanı; daha geniş kapsamda mimari ve teori ve pratik başta olmak üzere farklı ölçeklerde ve bağlamlarda incelenir. “Parçalar” teması içinde “parçalama ve birleştirme/hatırlama” anatomi müzesi mekânında meydana gelen ufuk açıcı bir olgu olarak tanımlanır ve incelenir. Anatomi sergilerinde yaygın olarak kullanılan “parçalar halinde sergileme” fikri, mimarlığın sergilenmesi için yeni ve ilham verici bir yöntem olarak sunulur. Rem Koolhaas’ın 14. Venedik Mimarlık Bienali için küratörlüğünü yaptığı *Elements of Architecture* sergisi bu bağlamda incelenir.

Anahtar Kelimeler: Anatomi Müzesi, Anatomi Tiyatrosu, Anatomik Sergileme, Mimarlığın Sergilenmesi, Parçalar Halinde Sergileme

To all women who bravely think, speak, and create

ACKNOWLEDGEMENTS

First and foremost, I owe my deepest gratitude to my thesis supervisor Prof. Dr. Ayşen Savaş for introducing me to the intriguing world of anatomical displays and their display environments and guiding me throughout the course of this thesis. Any thanks would be an understatement for her stimulating suggestions, illuminating contributions and encouragement. I believe this inspiring journey that we have shared since the Fourth-Year Design Studio has not come to an end. I hope her foresight and peerless knowledge will accompany me in my future studies.

I am grateful to Prof. Dr. Güven Arif Sargın who has been a mentor, a role model, and an unconditional supporter to me from my undergraduate years onwards. I would also like to express my appreciation to Prof. Dr. Jale Erzen for guiding me and broadening my horizon during my graduate studies. I owe my intellectual profundity and architectural skills to the distinguished members of METU Department of Architecture.

I would also like to thank to my jury members, Prof. Dr. Esin Boyacıođlu and Assist. Prof. Pelin Yoncacı Arslan for their constructive comments and valuable critics.

Without a doubt, I have been blessed with a supportive group of friends. I offer my sincere thanks especially to Cemre Önertürk, who has been a great companion to me through every step of this study. I would like to express my gratitude to my non-biological sisters Emine Esra Nalbant, Derin Deniz Ergun, Sim Üstüner, and Çađla Kuzu for supporting me not only during my thesis writing process but in my entire personal and professional life since high school. I would also like to thank to Sezin Sarıca, Ekin Sancak and Gizem Yetiş for their friendship since the very beginning of my adventure in architecture. Their presence has always been very comforting for me, helping me to overcome any kind of hardships. I am indebted to Buse Kırmaz for her unprecedented support, especially during the time we shared in Madrid. She has always been there for me. I am also grateful to Miya Kane for her help as a native

English speaker and as a dear friend who provides emotional support whenever I need.

I would like to express my heartfelt gratitude to Ege Korkan for his unconditional care and warm encouragement. This thesis would not have been accomplished without his immeasurable support. I will always be thankful for his generosity, kindness, and patience.

Last but not the least, I would like to thank to my family, although no words are enough to express my gratitude. I am most thankful to my parents; my mother for inspiring me to become an architect and her endless care; my father for his unconditional love, and insightful guidance. Their limitless tolerance, support and trust means a world to me. Special thanks to my little sister Nehir, for saving me from my worries and making me smile whenever I feel down. I am lucky to have my aunt Prof. Dr. Gülnur Tarhan, who has always supported me in all my endeavors in life. I am also deeply grateful to my dear grandparents for their compassionate encouragement since I was a baby. My gratitude never ends.

TABLE OF CONTENTS

ABSTRACT	v
ÖZ.....	vii
ACKNOWLEDGEMENTS	x
TABLE OF CONTENTS	xii
LIST OF FIGURES	xv
FIGURES	xv
CHAPTERS	
1 INTRODUCTION.....	1
2 ANATOMY MUSEUMS AND THE SPACES AROUND.....	13
2.1. The Emergence and Development of the Anatomy Museums.....	13
2.1.1. From Cabinets to Museums.....	13
2.1.2. The Status of Museum Architecture and the Anatomy Museum Today.....	40
2.2. Medical Gaze and the Shaping of the Spaces of Anatomy	56
2.2.1. Medical Gaze as a Model of Perception.....	56
2.2.2. Activities and Spaces Under the Influence of the Medical Gaze	66
2.3. Display of the Anatomical Body	97
2.3.1. Systems of Visual Display.....	97
2.3.2. The Art of Anatomy	101
2.3.3. Multimedia Mapping of the Body	118
2.3.4. “Real” and Representational Bodies	122

2.3.5.	The Experience of Embodiment	130
3	ANOTHER DISPLAY ENVIRONMENT: THE ANATOMICAL THEATRE	
	137	
3.1.	Memory and Theatre.....	137
3.1.1.	Representational Systems	137
3.1.2.	The Art of Memory	144
3.1.3.	Memory Theatre.....	152
3.2.	Architecture of Knowledge: Spaces for Seeing and Knowing	164
3.2.1.	From Memory Theatre to Anatomical Theatre	164
3.2.2.	Museum, Theatre and Library.....	173
3.2.3.	Theatre Architecture and the Design of Anatomical Theatres.....	182
3.2.4.	Ocular Anatomy and Ocular Space.....	199
3.3.	Public Dissection: Making the Body Visible.....	212
3.3.1.	Anatomical Theatre as a Didactic Space	212
3.3.2.	Anatomical Theatre as a Performance Space.....	215
4	ARCHITECTURE AND THE BODY	225
4.1	Order, Proportion and Harmony	226
4.2.	Space, Form and Function	237
4.2.1.	Bodyscape: The Architecture of the Body.....	239
4.2.2.	Architectural Visualization of the Body	262
4.2.3.	Spatialization of the Body in Museum Space	286
4.3.	Transparency.....	291
4.3.1.	The Visible Invisible.....	291
4.3.2.	Invisible Made Visible in Museum Space	295

4.3.3.	X-Ray Visualization	299
4.3.4.	Layering.....	319
4.4.	(Dis)section.....	329
4.4.1.	The Cut: Anatomization of the Body	329
4.4.2.	Representing the Dissection	335
4.4.3.	The Architectural Cut: Section.....	339
4.5.	Fragments	352
4.5.1.	(Dis)membering.....	352
4.5.2.	Dismembered Body Re-membered in Museum Space.....	358
4.5.3.	Display in Fragments.....	366
5	CONCLUSION	381
	REFERENCES	387

LIST OF FIGURES

FIGURES

Figure 1. Ole Worm's museum in Copenhagen from <i>Museum Wormianum</i> (1655).	18
Figure 2. Surgeon's Hall, Royal College of Surgeons of Edinburgh	19
Figure 3. Playfair Hall, Royal College of Surgeons of Edinburgh	21
Figure 4. Engraving representing the internal courtyard of Palazzo Poggi by Giovanni Battista Brustolon, 1756.....	23
Figure 5. Engraving representing the internal courtyard of Palazzo Poggi by Bartolomeo Crivellari, 1756	23
Figure 6. A view of Ercole Lelli's anatomy room, realized for the Bolognese Institute of the Sciences.	24
Figure 7. Dr. Hunter's Sketch of a Theatre, Museum, etc. published as part of the appendix to William Hunter's <i>Two Introductory Lectures</i> (1784)	27
Figure 8. Ground floor plan of William Hunter's house, museum and anatomy school at Great Windmill Street, by Robert Mylne, c.1765-1767	28
Figure 9. Sketch of the ground plan of John Hunter's house and anatomy school at Leicester Square in 1792 by William Clift, 1832	30
Figure 10. Ground and first floor plans of John Hunter's museum and house in Leicester Square, attributed to George Byfield, probably c.1801	30
Figure 11. Section perspective view of John Hunter's house, anatomy school and purpose-built museum at Leicester Square, London in 1792 made by John Ronayne, 2005	31
Figure 12. Sketch showing the display layout of the museum prepared by William Clift in 1806	34
Figure 13. Room I of V of the Hunterian Museum, around 1900.	38
Figure 14. The larger of the two galleries that comprised the Hunterian Museum in 1842. Watercolor by Tomas H. Shepherd.....	40

Figure 15. The “Crystal Gallery” in the 2005 refurbishment of the Hunterian Museum	40
Figure 16. The eastern facade of the Louvre Museum, Paris, 19th-century print ..	43
Figure 17. <i>Museumsquartier</i> Vienna	44
Figure 18. Interior perspective drawing of R. Solomon Guggenheim Museum by Frank Lloyd Wright, "The Masterpiece," 1958.	45
Figure 19. Elevation from Fifth Avenue facing east of Solomon R. Guggenheim Museum, New York City, 1943-59.	46
Figure 20. Definitive project model of Centre Pompidou, 1973 by Renzo Piano and Richard Rogers	47
Figure 21. Centre Pompidou from Sacré Cœur Basilica Montmartre Paris, 2017 ..	48
Figure 22. Image showing Guggenheim Museum together with the city of Bilbao. Colors edited by the author.....	49
Figure 23. Musée des Confluences designed by Coop Himmelb(l)au, 2014	52
Figure 24. Exterior view of Corpus. Voyage through the human body, Oegstgeest.	53
Figure 25. Front view of the Mutter Museum in Philadelphia. Colors edited by the author.....	55
Figure 26. View of Marischal College Aberdeen, looking towards the sea in the distance, c.1906	70
Figure 27. Floor plan, Anatomy Department, Marischal College, University of Aberdeen, as 2009.	71
Figure 28. Mortuary in the Anatomy Department, Marischal College, University of Aberdeen, mid 20 th century	72
Figure 29. Workshop in the Anatomy Department, Marischal College, University of Aberdeen, mid 20th century	74
Figure 30. Museum store in the Anatomy Department, Marischal College, University of Aberdeen, 2007	76
Figure 31. Lecture theatre with an ear model on the table in the Anatomy Department, Marischal College, University of Aberdeen, 1964	78

Figure 32. Science laboratory with osteological specimens on study tables in Anatomy Department, Marischal College, University of Aberdeen, c.1960.....	79
Figure 33. Dissecting room in the Anatomy Department, Marischal College, University of Aberdeen, 2007.....	81
Figure 34. Ground-floor bays and upper gallery of the Anatomy Museum, Marischal College, 2007.....	85
Figure 35. Technician’s contact prints showing views of the gallery in the Anatomy Museum, Marischal College, University of Aberdeen, c. 1980s. Image cropped and edited by the author.....	86
Figure 36. Ground floor displays and the gallery of the Anatomy Museum, Marischal College, University of Aberdeen, 2007.....	88
Figure 37. The plan drawing of the American Museum of Natural History as included in the Annual Report of the Trustees for the year 1920.....	90
Figure 38. Entrance corridor, Anatomy Department, Marischal College, University of Aberdeen, c.1906.....	92
Figure 39. Entrance corridor, Anatomy Department, Marischal College, University of Aberdeen, 2007.....	93
Figure 40. Ground floor of the Anatomy Museum in the Anatomy Department, Marischal College, University of Aberdeen, 2003.....	94
Figure 41. A study table between the display cases in the Berlin Museum of Medical History at the Charité, sketch drawing made by the author, March 2019	96
Figure 42. A student studying in the Berlin Museum of Medical History at the Charité, sketch drawing made by the author, March 2019.....	96
Figure 43. Postcard with Leiden University students surrounded by the anatomical collections in a lecture room, around 1990.....	97
Figure 44. Anatomical illustration made by Stephen van Calcar from <i>De Humani Corporis Fabrica</i> by Andreas Vesalius (1543).....	103
Figure 45. Anatomical illustration made by Giulio de’ Musi (1535-1553) from <i>Romanae archetypae tabulae anatomicae novis explicationibus</i> by Bartolomeo Eustachi (d. 1574).....	103

Figure 46. Bartolomeo Passerotti, Michelangelo Conducting an Anatomy Lesson, ca. 1570.....	105
Figure 47. Separation of the Waters from the Firmament from Last Judgment (1536–1541) by Michelangelo, Sistine Chapel, Vatican.....	106
Figure 48. Computer-assisted removal of the figures showing kidney shaped mantle of the Creator, color highlighted version.....	106
Figure 49. The Birth of Venus by Sandro Botticelli (1486), exhibited in Uffizi Gallery, Florence.	108
Figure 50. Anatomical Venus model in Museum of Natural History in Florence	108
Figure 51. Realistic illustration made by Antonio Serantoni (1755-1815) from <i>Anatomica Universale</i> by Paolo Mascagni (1780-1837).....	110
Figure 52. Illustration by Paolo Morgari in Francesco Bertinatti, <i>Elementi di anatomia fisiologica applicata alle belle arti figurative</i> . Turin, 1837–1839. Lithograph. National Library of Medicine.	112
Figure 53. Gunther von Hagens, Body Worlds Exhibition, “Skinned Man.” 1997–present.....	114
Figure 54. Figure of the flayed muscle man holding his skin and flaying knife by Gaspar Becerra in <i>Historia de la Composicion del Cuerpo Humano</i> by Juan Valverde de Amusco. (1556).....	114
Figure 55. Saint Bartholomew holding a flayed skin from Last Judgment (1536–1541) by Michelangelo, Sistine Chapel, Vatican	114
Figure 56. Viral Landscapes, Helen Chadwick, 1988-89.....	115
Figure 57. Functional Portrait: Self Portrait while drawing, Marta De Menezes, 2002	116
Figure 58. Exploring fMRI data inside the AlloBrain.....	117
Figure 59. Wax model of a dissected uterus with twins, photograph by Saulo Bambi.	119
Figure 60. Engraving of a dissected uterus with twins by Charles Grignion after Jan van Rymsdyk, 1751	119

Figure 61. Berlin Museum of Medical History at the Charité, 2016, photograph by Laura Fiorio	120
Figure 62. Dissecting room of St. Thomas' Hospital, London, 1886.....	121
Figure 63. Anatomy study in McGill Medical School, 1884.....	122
Figure 64. Wet preparation of the vertical section of a boy's face, made by or for John Hunter, before 1793	126
Figure 65. Dry preparation of human head and neck, 1850-1900	126
Figure 66. Dry preparation of a lung, 19th century, from Berlin Museum of Medical History collection.....	126
Figure 67. Life-size wax model of female anatomy from the workshop of Francesco Calenzoli at La Specola in Florence	129
Figure 68. Photograph of a plastinated body by Gunther von Hagens, from the Body Worlds exhibition in Cleveland.....	130
Figure 69. Body Scanner Interactive installation, by Jussi Ängeslevä, 2001.	135
Figure 70. Illustration of the abbey referred in the 'Abbey memory system', Johannes Romberch, <i>Congestorium Artificiose Memorie</i> , 1533.....	147
Figure 71. The guidance of images to be used in the 'Abbey memory system', Johannes Romberch, <i>Congestorium Artificiose Memorie</i> , 1533.....	147
Figure 72. Plan of the Memory Theatre of Giulio Camillo	155
Figure 73. The Zodiac from Robert Fludd's <i>Ars Amemoriae</i> (p. 329).....	160
Figure 74. The Theatre from Robert Fludd's <i>Ars Amemoriae</i> (p. 330).....	162
Figure 75. Sketch of The Swan Theatre which was, a typical Elizabethan theatre by De Witt, 1596.....	162
Figure 76. The illustration in the first page of the <i>Ars memoriae</i> in Robert Fludd's <i>De utriusque cosmi historia, Tonus Secundus</i> , Oppenheim, 1619	163
Figure 77. The Mirror of the Whole of Nature and the Image of Art by Robert Fludd, 1617. Colors edited by the author.....	165
Figure 78. Engraving depicting the Leiden Anatomical Theatre by Willem van Swanenburgh after Jan Cornelisz. van't Woud (Woudanus), 1610.....	169
Figure 79. The ceiling of Bologna Anatomical Theatre	170

Figure 80. The Bolognese Anatomy Theatre after the eighteenth-century alterations from G. Tonelli, “Sul teatro anatomico dell’ Archiginassio”, <i>Strenna Storica Bolognese</i> , xxviii (1978)	171
Figure 81. A view of the Anatomical Theatre of Bologna showing the wall facing the entrance.....	172
Figure 82. William Hunter and the Anatomy of the Modern Museum exhibition (September 2018-January 2019) in Hunterian Museum, Glasgow	177
Figure 83. Roman theatre according to Vitruvius	184
Figure 84. Greek theatre according to Vitruvius	185
Figure 85. Engraving insterted in Plautus, <i>Comodiae XX</i> , Venice, 1511.....	186
Figure 86. Architectural design of an anatomical theatre from Carolus Stephanus, in his book “De dissectione partium corporis”, Paris 1546.....	187
Figure 87. <i>Theatrum anatomicum temporarium</i> . a. Woodcut illustration of the book <i>Anatomia Mundini</i> , Rostock, University Library ed. 1513. in G. H. Schumacher and H.-G. Wischhusen 1970.....	189
Figure 88. Woodcut illustration, <i>Anatomie de Mondin</i> Paris, A. Lotrian et D. Janot 1532.....	189
Figure 89. Copperplate engraving of the Anatomical theatre of Padua, 1654	191
Figure 90. <i>Theatrum anatomicum</i> in Leiden, c.1615.	192
Figure 91. Drawing showing the front façade of the University building "Gustavianum" in Uppsala with the <i>Theatrum anatomicum</i> at the top by Nils Sundquist.....	193
Figure 92. Interior of the anatomical theatre in Uppsala.....	193
Figure 93. Longitudinal section of the Anatomical Theatre of Bologna.....	195
Figure 94. Interior of the Anatomical Theatre of Bologna. Colors edited by the author.....	195
Figure 95. <i>Le Grand Amphithéâtre des Ecoles de Chirugie</i> Paris. Cupperplate engraving from Claude-René-Gabriel Poulleau, in: Gondoin, <i>Description des Ecoles de Chirurgie</i> , Paris 1780.	197
Figure 96. <i>Bibiena Scientific Theatre</i> , Mantua	199

Figure 97. Photograph showing the interior of Teatro Farnese	203
Figure 98. The floor plan drawing of Teatro Olimpico. Colors edited by the author.	205
Figure 99. Photograph showing the perspective scenery on Scaenae frons of Teatro Olimpico, by Terry Clinton.....	205
Figure 100. Illustration from <i>De humani corporis fabrica</i> by Andreas Vesalius, 1543 showing the optic chiasm. Colors edited by the author.	208
Figure 101. Illustration showing the optic chiasm by Isaac Newton, 1704.....	208
Figure 102. Scheiner’s illustration of viewing a point through two pinholes (Scheiner’s experiment).	208
Figure 103. Diagram illustrating the relationship between the distance of a visible object and the breadth of the visual rays cast onto the back of the eye from Johannes Kepler, <i>Ad vitellionem paralipomena</i> (1604).....	208
Figure 104. Scheiner’s illustration of the eyeball.	211
Figure 105. Plan of the fourth loges of Ledoux's design for a theatre at Marseille with sightlines.	211
Figure 106. <i>Coup d’oeil du théâtre de Besançon</i> from Claude- Nicolas Ledoux’s <i>L’Architecture considérée sous le rapport de l’art, des moeurs et de la legislation</i> (1804).....	212
Figure 107. Jan van Calcar, attributed, Frontispiece, woodcut, in Andreas Vesalius, <i>De humani corporis fabrica libri septem</i> (Seven Books on the Fabric of the Human Body) (1543, Basel)	219
Figure 108. Porch of the Maidens, Erechtheum	227
Figure 109. Vitruvian man by Leonardo Da Vinci (c. 1490).....	230
Figure 110. Human figure inscribed in church plan by Francesco di Giorgio	231
Figure 111. Entablature on the human form, by Francesco di Giorgio (ca.1492)	231
Figure 112. Study on human proportions from <i>Four Books on Human Proportion</i> (1532–34) by Albrecht Dürer.....	232
Figure 113. Architectural Forms from Vincenzo Scamozzi, <i>L’idea dell architettura</i> universal (1615)	233

Figure 114. Study on human proportions, Leon Battista Alberti, c.1600	233
Figure 115. Valeriano Pastor, sketch for the District School Center near Dolo. Nude female torso in a detail study sketch of the ribbed vaulting in the school's laboratories. (From Anfione Zeto, 1, 1989)	235
Figure 116. The Modulor by Le Corbusier	237
Figure 117. Different types of cells present in the human body. Colors edited by the author.....	241
Figure 118. The exterior of the Nakagin Capsule Tower as it appeared in 2015, photograph by Noritaka Minami	242
Figure 119. Human cartilage cells under microscope. Colors edited by the author.	242
Figure 120. Axonometric of a capsule unit by Kisho Kurokawa Architect & Associates.....	243
Figure 121. Three-dimensional section model of a cell	243
Figure 122. 4 major types of tissues present in human body	245
Figure 123. Real-time imaging of endothelial cells. Colors edited by the author.	246
Figure 124. Branching Morphogenesis installation exhibited in LA at Siggraph 2008	246
Figure 125. 100um diameter fluorescent image of normal breast tissue culture. Colors edited by the author.....	247
Figure 126. Ground Substance project exhibited in Siggraph 2009 in New Orleans	247
Figure 127. Dissected heart, brain and lung. Image prepared by the author.	248
Figure 128. Midsagittal Slices of a Male and Female Body, Body Worlds Exhibition by Gunther von Hagens. Colors edited by the author.....	248
Figure 129. Greg Lynn, Embryological House	250
Figure 130. A. Bartholomew, diagram comparing the counter-abutments of Gothic vaulting with the human skeleton.....	251
Figure 131. Reliance Building in Chicago under construction, August 1st 1894.	252
Figure 132. Dom-ino House by Le Corbusier, 1914-1915.....	252

Figure 133. Diagrammatic section of the human skin showing different layers and substructures. Colors edited by the author.	254
Figure 134. Facade cross-section of the Nykredit bank building, designed by Schmidt Hammer Lassen architects.....	254
Figure 135. eSkin project.....	255
Figure 136. BIX Communicative Display Skin for the Kunsthaus Graz, 2003, view from Schlossberg	257
Figure 137. Sketches showing the separation of the “skin and bone” from the frontispiece of Le Corbusier, "The Five Points of a New Architecture," 1929	259
Figure 138. Neue Nationalgalerie in Berlin designed by Mies van der Rohe (1968)	260
Figure 139. Schematic diagram showing sequential changes in uterine cervix in case of cancer	261
Figure 140. Anatomical illustration by Toviyah Kats (ca. 1652–1729) Venice, 1708.....	263
Figure 141. Illustration from <i>De dissectione partium corporis</i> by Charles Estienne, Paris, 1545. Colors edited by the author.	265
Figure 142. Illustration from Pietro da Cortona, <i>Tabulae Anatomicae</i> 1741. Plate XVII.	266
Figure 143. Illustration from Pietro da Cortona, <i>Tabulae Anatomicae</i> 1741. Plate XVI. Colors edited by the author.	266
Figure 144. Illustration from <i>De dissectione partium corporis</i> by Charles Estienne, Paris, 1545. Colors edited by the author.	267
Figure 145. <i>De dissectione partium corporis</i> by Charles Estienne, Paris, 1545. Woodcut. National Library of Medicine. Colors edited by the author.	268
Figure 146. <i>De dissectione partium corporis</i> by Charles Estienne, Paris, 1545. Colors edited by the author.	269
Figure 147. Second plate of the muscles from Vesalius, <i>De humani corporis fabrica</i> , 1543. Colors edited by the author.	270

Figure 148. Plate II, “Nerves of the Neck,” from Charles Bell, <i>A Series of Engravings Explaining the Course of the Nerves</i> (1803).....	271
Figure 149. Plate IV, an engraving of the arteries of the head, from Charles Bell’s <i>Engravings of the Arteries</i>	271
Figure 150. Source: A view from the interior of a nostril. Fritz Kahn, <i>Das Leben des Menschen</i> , Vol. 2. (1926) Colors edited by the author.	272
Figure 151. Diagram showing image translation from eye to brain. René Descartes, <i>Tractatus de homine, et de formatione foetus</i> , 1677.	273
Figure 152. Fritz Kahn, “The Oxygen Cycle”, <i>Das Leben des Menschen: Volkstümliche Anatomie, Biologie, Physiologie und des Menschen</i>	275
Figure 153. Fritz Kahn, <i>Der mensch als industriepalast</i> . Stuttgart,1926.....	277
Figure 154. Fritz Kahn, <i>Das leben des menschen; eine volkstümliche anatomie, biologie, physiologie und entwicklungsgeschichte des menschen</i> . Vol. 2. Stuttgart, 1926. Tafel XIII.....	278
Figure 155. Fritz Kahn, <i>Das leben des menschen; eine volkstümliche anatomie, biologie, physiologie und entwicklungsgeschichte des menschen</i> . Vol. 2. Stuttgart, 1926. Tafel XV.....	278
Figure 156. Fritz Kahn, <i>Man in Structure & Function</i> , Vol. 1. New York, 1943. Colors edited by the author.....	280
Figure 157. The model and plans of Maison Citrohan. Colors edited by the author.	280
Figure 158. Some features of modern architecture that promote human comfort and health, Villa Savoye by Le Corbusier. Colors edited by the author.	282
Figure 159. Analytical diagrams of Unite d’Habitation showing concern towards human comfort, Le Corbusier.....	283
Figure 160. <i>Anatomy of a Dwelling</i> by François Dallegret	285
Figure 161. Regional display in Anatomy Museum in the Anatomy Department, Marischal College.....	288
Figure 162. Regional display in the Museum of Anatomy, University of Glasgow, 2007	288

Figure 163. Interior of Corpus Museum, Oegstgeest.....	290
Figure 164. Interior of Corpus Museum, Oegstgeest.....	290
Figure 165. Mouth section of, Corpus Museum, Oegstgeest.....	291
Figure 166. A wax Anatomical Venus shown intact and partially dissected, made in Rudolph Pohl workshop in Dresden, Germany, circa 1930. Courtesy the Münchner Stadtmuseum, Sammlung Puppentheater/Schaustellerei, Munich.	294
Figure 167. Museum technician making transparent Perspex cases for specimens at the Royal College of Surgeons of England, c.1960	296
Figure 168. Berlin Museum of Medical History at the Charité	298
Figure 169. Fresh air therapy is just one of a range of holistic treatments used in early 20th-century mental hospitals.	300
Figure 170. Jean Saidman, revolving sanatorium, Aix-les-Bains, France, 1930..	300
Figure 171. Children exercising on the terrace of the physical education institute of Karla Hladka dancing school	300
Figure 172. Artificial beach, Aix-les-Bains	301
Figure 173. A section of the exhibit on respiration, Health Exposition of Berlin, 1935. From: H.E. Kleinschmidt, “New Germany teaches her People. An Account of the Health Exposition of Berlin”, American Journal of Public Health and the Nation’s Health , 1935, 25 , p. 1112.	301
Figure 174. The hand of Bertha Roentgen: the first X-ray image, 1895.	302
Figure 175. Le Corbusier portrayed as a biologist. Pierre Winter. “The Point of View of a Biologist.”1993. Colors edited by the author.....	305
Figure 176. Cover of the Revista Nacional de Arquitectura 126, June 1952, with an image of Lake County Tuberculosis of Sanatorium superimposed on an X-ray of lungs	305
Figure 177. Terrace of the villa Stein at Garches. Film still from L’Architecture d’aujourd’hui, 1929, by Pierre Chenal and Le Corbusier	305
Figure 178. Le Corbusier, Architecture et urbanisme, suspended garden, Immeuble Wanner, Geneva, 1928-1929.	305
Figure 179. Marcel Breuer, apartment for Hilde Levi in Berlin, 1930	306

Figure 180. Theo Effenberger, house in the Werkbund housing exhibition, Breslau, 1929	306
Figure 181. Walter Gropius, communal gym for apartment house, German Building Exhibition, Berlin, 1931	306
Figure 182. Bernard Bijvoet, Jan Duiker, Open Air School for Healthy Children	307
Figure 183. Postcard of children resting and bathing in the sun in Suresnes open-air school.....	307
Figure 184. Classroom with retractable walls	307
Figure 185. Silhouette and X-ray of the same head, used as illustration in Mies van der Rohe's article in <i>G:Zeitschrift für elementare Gestaltung</i> , no. 5-6. April 1926.	308
Figure 186. Franz and Fritz Tschakert, Transparent Man, 1927. Mixed media. German Hygiene Museum, Dresden.	310
Figure 187. Mies van der Rohe, model of the Glass Skyscraper, Berlin, 1922.....	310
Figure 188. Philip Johnson, Glass House, New Canaan, CT, 1949	310
Figure 189. Mies van der Rohe, Farnsworth House, 1949	311
Figure 190. Le Corbusier's project for the Glass Skyscraper, 1925	312
Figure 191. R. Buckminster Fuller, Streamlined Dymaxion Shelter prototype, 1932	312
Figure 192. George Keck, Crystal House, 1933-1934, exhibited at the World's Columbian	312
Figure 193. Frits Peutz, Schunck Glass Palace, Heerlen, the Netherlands, 1935 .	313
Figure 194. Reflections in the Glass House, Philip Johnson, New Canaan, Connecticut, 1949.....	316
Figure 195. SANAA, rendering of the Glass Pavilion at the Toledo Museum of Art, Ohio, 2006	317
Figure 196. Novartis Pharma Headquarters, Basel, 2002	318
Figure 197. View of SANAA's installation in the Mies van der Rohe Pavilion, Barcelona, 2008.....	318

Figure 198. View of SANAA's installation in the Mies van der Rohe Pavilion, Barcelona	319
Figure 199. Jacob Frölich (after Heinrich Vogtherr), <i>Anatomy, or, a faithful reproduction of the body of a male (Anathomia oder abconterfettung eines Mans leib)</i> , 1544	322
Figure 200. Jacob Frölich (after Heinrich Vogtherr), <i>Anatomy, or, a faithful reproduction of the body of a female (Anathomia oder abconterfettung eines Weibs leib)</i> , 1564	322
Figure 201. Anatomy of the eye shown in layers of paper, from Gustave Joseph Witkowski, <i>Human Anatomy and Physiology. Part IV. A Movable Atlas Showing the Mechanism of Vision; The Eye; The Organs of Vision</i> (London, 1880-89) ..	323
Figure 202. Anatomy of the skeleton and organs shown in layers of paper, from William S. Furneaux, ed., <i>Philip's Popular Manikin</i> (London, c. 1900)	323
Figure 203. Anatomy of the forearm in layers, from J. E. Cheesman, <i>Bailliere's Synthetic Anatomy: A Series of Drawings on Transparent Sheets for Facilitating the Reconstruction of Mental Pictures of the Human Body, Part 2. The Forearm</i> (London, 1926-36)	325
Figure 204. Axonometric of Le Corbusier's <i>Still Life</i> , 1920	326
Figure 205. Le Corbusier, <i>Still Life</i> , 1920	326
Figure 206. Axonometric of Le Corbusier's Villa Stein at Garches 1927-8	326
Figure 207. Photograph of Le Corbusier's Villa Stein at Garches 1927-8	326
Figure 208. Plan and Section drawings of Moller house in Vienna designed by Adolf Loss	328
Figure 209. Villa Müller in Prague designed by Adolf Loos'	328
Figure 210. Axonometric analysis diagram of Terragni's Casa del Fascio	329
Figure 211. Anatomage Table	335
Figure 212. Pietro da Cortona, <i>Tabulae Anatomicae</i> 1741. Plate IX.	337
Figure 213. Copperplate engraving by Daniel Le Bossu in <i>Nouvelles tables anatomiques</i> , Amé Bourdon. 1678	337
Figure 214. Adriaan van de Spiegel, <i>De formato foetu liber singularis</i> , 1626	338

Figure 215. Woodcut engraving by Stephen van Calcar in <i>De humani corporis fabrica</i> , Andreas Vesalius, 1543	338
Figure 216. Illustration showing ribs, organs and blood vessels, colored lithograph by William Fairland from Francis Sibson, <i>Medical Anatomy</i> (London, 1869)	338
Figure 217. A female torso with opened uterus and foetus, c.1770 made for William Hunter.....	339
Figure 218. Gordon Matta-Clark, <i>Conical Intersect</i> , 1975.....	342
Figure 219. Gordon Matta-Clark, <i>Conical Intersect</i> , 1975.....	342
Figure 220. Leonardo Da Vinci, <i>Embryo in the Womb</i> , ca. 1510	343
Figure 221. Sliced medieval building part in <i>Dictionnaire raisonné de l'architecture française</i> by Viollet-le-Duc (1854-1868)	344
Figure 222. Exploded view of the skull, in <i>Traite complet de l'anatomie de l'homme comprenant la medecine operatoire</i> by Jean-Baptiste Bourguery, Paris, 1831	344
Figure 223. The right leg of a man cut into sections by Leonardo Da Vinci	346
Figure 224. Chromolithograph by C. Schmiedel in <i>Topographisch-anatomischer atlas nach durchschnitten an gefrorenen cadavern</i> , Wilhelm Braune Leipzig, 1872.	346
Figure 225. Photographs from Visible Human Project	347
Figure 226. The sliced body cross section display at The Body Worlds and the Cycle of Life exhibition at Telus World of Science in Edmonton, photo by Graeme Archibald, 2013	347
Figure 227. Principle of volumetric image acquisition in CT.....	349
Figure 228. Computerized axial tomography (CAT) scans.....	349
Figure 229. Multiple X-ray computed tomographs.....	349
Figure 230. Jose Luís Mateo, Ed. <i>Architekturgalerie</i> . Luzern, 1992.	350
Figure 231. Transversal sections of Yokohama International Port Terminal, Foreign Office Architects.	351
Figure 232. Observation deck plan of Yokohama International Port Terminal, Foreign Office Architects.	351

Figure 233. Suspended Self Portrait by Carolyn Henne. Sculpture installation. 2001, photo by Travis Fullerton.....	351
Figure 234. Chromolithograph by Louis Courtin in Jean-Baptiste Sarlandière, <i>Anatomie méthodique, ou Organographie humaine en tableaux synoptiques, avec figures</i> (1829).....	353
Figure 235. Anatomical Venus probably modeled by Clemente Susini, c.1790 at Natural History Museum of Florence, Italy.....	355
Figure 236. Anatomical Venus at Natural History Museum of Florence in various stages of dissection. Photos by Saulo Bambi, as seen in Taschen’s Encyclopedia Anatomica.....	355
Figure 237. Anatomical Venus in Wellcome Collection, probably made at the workshop of Clemente Susini and Francesco Calenzuoli in Florence between 1776 and 1780.....	356
Figure 238. Anatomical model by Louis Auzoux, 1879, Paris.....	357
Figure 239. Anatomical specimens in jars in John Hunter’s museum at the Royal College of Surgeons in London	359
Figure 240. Marcel Duchamp, <i>Nude Descending a Staircase, No. 2</i> , 1912.....	364
Figure 241. Étienne-Jules Marey with Georges Demeny <i>Untitled (Sprinter)</i> , after 1893.....	365
Figure 242. <i>Femme assise dans un fauteuil gris (Woman Seated in a Grey Armchair)</i> , 1939.....	365
Figure 243. The system of the five classical orders according to Claude Perrault. (From Briseux’s <i>Traité du Beau Essentiel</i>).....	367
Figure 244. Briseux’s analysis of Vignola’s proportional rules, offered as a historical demonstration of the author’s principles. (From Briseux’s <i>Traité du Beau Essentiel</i>).....	367
Figure 245. Façade drawings of Buonaccorso Giberti (Florence 1451-1516).....	368
Figure 246. Facade of Santa Maria Novella designed by Leon Battista Alberti, constructed in 1470, Florence, photograph taken before 1922	369
Figure 247. Staircase models at the Friedrich-Mielke-Institut für Scalalogie.	371

Figure 248. Specimens with Brain Tumors in Berlin Museum of Medical History at the Charité	371
Figure 249. Photograph from the Window section in Elements of Architecture in 14 th Venice Architecture Biennale, 2014, designed by Rem Koolhaas.....	373
Figure 250. Face moulage exhibit in Berlin Museum of Medical History at the Charité	373
Figure 251. Layout of the W.D. Trotter Anatomy Museum at the University of Otago in New Zealand, arranged with the method of regional display.....	374
Figure 252. Elements of Architecture exhibition layout	374
Figure 253. Ceiling section of Elements of Architecture	375
Figure 254. Window section of Elements of Architecture	375
Figure 255. Corridor section of Elements of Architecture	376
Figure 256. Floor section of Elements of Architecture	376
Figure 257. Balcony section of Elements of Architecture	377
Figure 258. Fireplace section of Elements of Architecture.....	377
Figure 259. Façade section of Elements of Architecture	378
Figure 260. Roof section of Elements of Architecture.....	378
Figure 261. Door section of Elements of Architecture.....	379
Figure 262. Wall section of Elements of Architecture	379
Figure 263. Stair section of Elements of Architecture	380
Figure 264. Ramp section of Elements of Architecture	380

CHAPTER 1

INTRODUCTION

The initial idea of this study was originally derived from the concepts and perspectives established throughout the “eye-opening” discussions held for the creation of the unpublished EU project proposal entitled “La Specola”¹. The inspiration directing towards the field of scientific displays and their display spaces, especially the university museums, engendered the interest in the display of the human body in the context of anatomical science and the sites where this display takes place. In this regard, this thesis that focuses on the spaces and objects of anatomical display have been developed. Throughout the entire process, the impressions and experience gathered from the visits of the author to the Body Worlds Exhibition (Istanbul, 2010), Berlin Museum of Medical History at the Charité, Veterinary Anatomical Theatre in Berlin, Anatomical Theatre of Bologna and Javier Puerta Museum of Anatomy in Madrid, guided and enhanced the study.

The extensive literature search carried out on the subject of “anatomical displays and their display spaces” has shown that the majority of the existing publications have handled the issue from the viewpoints of museology, medical history, art history, philosophy, anthropology, and visual and material culture studies, though not from an architectural perspective. Despite the implied presence of “architecture” in these works, there are nearly no studies, dealing specifically with this subject, directly from an architectural point of view. It seems like, for centuries architecture has been, in some way, left out of this multidisciplinary and seminal academic discourse. In

¹ Unpublished project proposal entitled “La Specola” submitted for Erasmus+ KA2: Cooperation for innovation and the exchange of good practices - Knowledge Alliances 2018 (EAC/A05/2017). Project coordinator: Prof. Dr. Ayşen Savaş.

that sense, this thesis aims to provide an in-depth study of the spaces and objects of anatomical display from an architectural standpoint, that would contribute both to the architectural discipline and to many others, that are directly or indirectly interested in the display of the human body as an anatomical object, in terms of establishing creative links between body and space, providing new perspectives on display practices and the perception of *corporeal* objects.

At this point, it is necessary to mention that the relationship between architecture and the body has been vastly studied so far, at a metaphorical/analogical level or within feminist discourse, gender studies, phenomenological discourse, and studies related to health and well-being. Theoretical works of Bernard Tschumi, Diana I. Agrest and Peter Eisenman on feminism and gender, writings of Christian Norberg-Schulz, Juhani Pallasmaa and Steven Holl on phenomenological perception², studies of Anthony Vidler, especially his renowned article “Building in Pain”³ discussing the “bodily projection in architecture” from corporeal to psychological metaphors, and the statements of the modernists on providing health and wellness through modern architecture, related human body to architecture in many different aspects. The very recent publication of Beatriz Colomina entitled “X-Ray Architecture”⁴ examining the influence of medical discourse and diagnostic technologies on the design, representation and perception of modern architecture, introduced a novel and compelling theory to the architectural discourse that has never been elaborately discussed previously. The approach of Colomina, presenting an innovative insight towards the interaction between architecture and medicine provided a significant contribution to this study by means of inspiring the way of thinking that underlies it.

In the light of all these highly influential studies, this study intends to present an unconventional reading of the relationship between architecture and the body, through the particular concept of anatomical display. Therefore, the areas below are

² Kate Nesbitt, ed., *Theorizing a New Agenda for Architecture: An Anthology of Architectural Theory 1965-1995* (New York: Princeton Architectural Press, 1996).

³ Anthony Vidler, “The Building in Pain: The Body and Architecture in Post-Modern Culture,” *AA Files*, no. 19 (1990): 3–10, <https://www.jstor.org/stable/29543679>.

⁴ Beatriz Colomina, *X-Ray Architecture* (Altenburg: Lars Müller Publishers, 2019).

investigated to find the points where architecture intersects with anatomy within the context of display:

- Spaces of anatomical display
- Visualization and display methods of the anatomical objects
- Anatomical structure of the human body

Interweaving the findings gathered from these areas, the main argument of this thesis is built in three chapters. The chapter organization reflects the research process of this study beginning with anatomy museum, proceeding with anatomical theatre and closing with examination of the architecture-body relations in a broader context. The discursive nature of the research subject led to a complex research process, thus created an interdisciplinary, multi-content and multi-context network of ideas, that is reflected on the structuring of the entire work. During the textual composing of this study, the temptation to offer a chronological history of anatomical displays and display spaces is strictly avoided. Therefore, the chapters do not correspond to certain time periods, instead each one is dedicated to a distinct theme related to the main idea. Furthermore, the arguments are built around binary oppositions such as visible-invisible, transparency-opacity, part-whole and interior-exterior and all the chapters and subchapters are connected to each other through these opposing pairs that suggest multiple meanings and stimulate further thinking. The strong bond between “seeing and knowing”⁵ as described by Foucault, is the key element that constitutes the essence of all the statements and shapes the entire study.

As Chapter 1 being the introduction, in Chapter 2, the main display space of the anatomical body, the anatomy museum, is explored. Anatomy museum is described as an “unusual space”, both tempting and repulsive for its visitors and having a unique character fitting into the “heterotopic space”⁶ description of Michel Foucault. After introducing the anatomy museum beyond its book definition, as a place of

⁵ Michel Foucault, *The Birth of the Clinic: An Archaeology of Medical Perception* (London: Routledge, 2003).107

⁶ Michel Foucault, “Of Other Spaces: Utopias and Heterotopias,” *Diacritics* 16, no. 1 (1986): 22–27, <https://www.jstor.org/stable/464648>.

novelty, wonder, curiosity and inspiration, the emergence and formation process and the setting of anatomical collections and the spaces that have housed them are studied in relation with the intellectual context of the corresponding time period. The birth and historical development of the Royal College of Surgeons, Bologna Anatomy Museum and Hunterian Museum are examined in detail. Throughout this study, a specific focus is given to the initial setting of the Hunterian collection regarding its complex yet ordered spatial arrangement. An important statement for this thesis, regarding the anatomy museums and the role of curator-anatomists, is made by Thomas A. Markus:

“...juxtaposition of spatial and natural order reinforced the status of the anatomist by linking the microcosmic scale of the dissected body and the macrocosmic divine architecture of the natural world.”⁷

Following the portrayal of the advent of the anatomy museum as a didactic space supporting anatomy education, the architectural status of the anatomy museums is investigated in relation to the new culture of museum architecture that appeared in the early 20th century and has developed since then.

The concept of the “medical gaze” introduced by Foucault in “The Birth of the Clinic: An Archaeology of Medical Perception”⁸ is quite significant for this study as it provides a model of perception that has both medical and spatial quality. According to the definition of Foucault, the medical gaze is beyond the mere act of “seeing”, it has the ability to plunge into a space and traversing it. By moving across the surfaces and linking them in three-dimensions, the medical gaze maps a volume. The activity of the medical gaze is analytical, it aims to comprehend what is beyond the visible surface, the inner depths of an object. It is a profound spatial reading. As the medical gaze operates on the patient, the volume or space referred here could be understood as the body of the patient. Therefore, what is plunged into, traversed and mapped

⁷ Thomas A. Markus, “Domes of Enlightenment: Two Scottish University Museums,” *Museum Management and Curatorship* 4, no. 3 (1985): 215–42. quoted in Simon Chaplin, “John Hunter and the ‘Museum Oeconomy’, 1750-1800” (PhD Thesis, King’s College London, 2009).200

⁸ Foucault, *The Birth of the Clinic: An Archaeology of Medical Perception*.

becomes the human body. In this respect, the description of the body as a spatial and mappable entity presents an uncommon way of perceiving the body.

The three-dimensional mapping of the body takes place in mind through the visual data gathered by the eye. This process is defined as “anatomical visualization” and considered to be an advanced skill for medical education and practice, as written by Elizabeth Hallam. The concept of “mind’s eye”, that refers to the mental ability of conceiving imaginary or recollected visions, and “mental imagery”, which is a quasi-perceptual experience highly used in mnemonics, aiding the creation and preservation of an image in mind, are essential for understanding the idea of anatomical visualization.

This study asserts that the medical practice, thus the spaces accommodating the medical activities have been designed and developed under the influence of medical gaze. It is claimed that the complex nature of medical gaze caused the medical activities to be manifold and highly interlinked which led to the interwovenness and the variety of the medical spaces. In particular, it is argued that this condition is most visible in medical school campuses. In better terms, the complexity of the medical education manifests itself in the complexity of the architectural program of the medical school campuses.

Despite its sophisticated abilities medical gaze is essentially about the intense connection between “seeing and knowing”. Therefore, among the spaces in medical schools, anatomy museum comes to fore. Anatomy museum, in terms of being a space entirely devoted to display, directly addresses the eye. It is a space, fundamentally designed for the visual reception of the anatomical body in display. Anatomy museum is a space for “knowing” the human anatomy by “seeing” it. In that sense, the role of the anatomy museum in medical education has been highly significant. Towards the end of the 18th century anatomy museums became an essential part of the medical schools, as visualization and display have become extremely important for anatomical teaching. It is no coincidence that, this time

period is the same with the time when the powers of the medical gaze began to be discovered and the *clinic* was born.

Another major argument of this study is that the multifaceted design of the anatomical education, and consequently the architectural program accommodating the educational practices, resulted in the transformation of the spaces other than the anatomy museum, such as the dissecting room, workshop, laboratory and museum store, into display environments. Since the display of the body is not considered to be limited to the space of anatomy museum, in many sentences the more comprehensive phrase “display space” is deliberately used instead of “museum”.

The last part of Chapter 2 focuses on the distinctive qualities of anatomical display. Based on the argument suggesting the transition of spaces other than the anatomy museum into display environments, the complex spatial setting of medical schools are defined as a “system of visual display” where the anatomy museum constitutes the heart. In the light of this definition, the unique conditions that connote polysemic, ambiguous and multi-layered associations regarding the display of the anatomical body are examined. For the display of the human anatomy, various methods oscillating between art and science have been employed and the simultaneous use of diverse media is favored by museum authorities and leading medical scholars to enhance the effectiveness of anatomy education and the generation and dissemination of anatomical knowledge. In anatomy museum, “the object itself” and “its representations” are exhibited together which is an idiosyncratic display condition for the museum collections. Although the distinction between the “real” and the “representation” might seem evident, the case of anatomical display suggests a more complicated condition. In that sense, the concept of “reality” or the “reality affect” is explored through different types of anatomical display objects. In addition, the idea of “embodiment”, which is quite significant for the museum displays in general, is discussed within the context of anatomy museum and the notion of “embodied experience” is analyzed in this respect.

Between anatomical theatre and museum there have been deep historical, functional, conceptual and spatial connections. Among these connections, the idea of “display” being the key element that theoretically and physically shaped both spaces, comes to the fore. Regarding that, the consideration and study of the anatomical theatre as a display space becomes meaningful and thought-provoking. In that sense, Chapter 3 focuses on the development of anatomical theatres as “spaces of display” in relation with the prominent Renaissance notions, ideals, spaces and settings – such as cabinets of curiosities, cabinets of the world, world view/picture, *theatrum mundi*, art of memory and memory theatre – and the cosmological understanding of the era.

The concept of remembering plays an important role for this study, hence it is mentioned and discussed from various aspects in different contexts and related to distinct practices and notions throughout the thesis. It is claimed that the practice of the art of memory, centering around the concepts of remembering, mental visualization and visuo-spatial cognition, relates to the “medical gaze”, thus to the anatomy education and practice. The fundamental notions of anatomical visualization such as “mind’s eye” and “mental imagery”, are also crucial for the art of memory, especially for the architectural type called the “method of *loci*”. Likewise, the concept of “inner vision” that is necessary for the practice of the art of the memory draws similarities to the “medical gaze” in terms of presenting a deep perception beyond sight, involving analytical actions such as selecting, ordering and synthesizing.

Within the scope of this study, theatres together with museums and libraries are defined as “spaces of knowledge” and their historical ties are explored. Different from museum architecture, theatre architecture suggests a specific architectural form dating back to ancient Greece. Regarding that, the influence of theatre architecture on the design of the anatomical theatres is analyzed within the context of “seeing and knowing”. The activity of “public dissection” accommodated in the space of the anatomical theatre is examined both as an educational and performative practice.

As Chapter 2 and 3 being more specific in terms of discussing particular architectural spaces and themes related to the display of the human body as an anatomical object, Chapter 4 portrays a general perspective regarding the relationship between architecture and the anatomical body. In that sense, Chapter 4 goes beyond the physical limits of anatomy museum and other display spaces and expands towards the extensive field of architecture. To be more precise, the final chapter before the conclusion explores the interactions between the design, representation and reception of architecture and the human body as an anatomical/biological object and the visualization and display of it in a broader context, traversing times and places, to create a conceptual schema. The major concepts that the relationship between architecture and body are discussed upon, are also examined within the context of anatomy museum, to create continuum throughout the study based on the dominant theme of display, by linking Chapter 2 and 3 with Chapter 4.

Between architecture and the human body there is a deep-seated relationship established through analogical reasoning. There have been two distinct kinds of interpretation of this analogical relationship dating back to ancient times: one focusing on the visual aspects and composition, the other dwelling on the functional similarities. In many cases these two approaches are interrelated.

The idea of completeness, integrity and unity in a structure, ensuring the coherent settling of all the parts constituting the whole, disallowing the removal of even a tiny piece as it would cause the entire system to collapse, has been considered to be synonymous with the classical ideal of beauty. Therefore, since ancient Greece, the human body has been seen as the perfect model of harmonious balance and proportion for the design of architectural entities.

Regarding the fact that both the human body and architectural artifact are self-enclosed, three-dimensional entities with complex interiors, this study defines the body as a “spatial” object by attributing the quality of “space”, that is commonly associated with architecture, to the human body. Within this context, the idea of space is discussed in two aspects, form and function, thus the similarities between

architecture and the body are explored in morphological and functional terms through the analysis of various cases.

The relationship between the body and architecture upon the concept of “space” is also analyzed within the context of anatomy museum. The complex process that the human body goes through in anatomy museum is defined as “spatialization”. The method of “regional display” which refers to the organization of the museum space as an anatomical body is explored as an embodiment of this spatialization process.

After discussing the two main interpretations of the analogical relationship between architecture and body under the concepts of “order, proportion and harmony” and “space, form and function”, the study continues with a deeper analysis centering upon the seminal condition arising from the tension between visibility and invisibility. The human body is defined as “visible invisible” referring both to its “visibility” as a physical entity and historical connotation as the symbol of the material world, and to the “invisibility” of its articulated interiors underneath the skin, embodying all the corporeal knowledge waiting to be disclosed. The anatomical display in the museum space is examined in the light of the definitions, “literal and phenomenal transparency”⁹, introduced by Colin Rowe and Robert Slutzky. The concept of transparency in architectural theory and practice is analyzed, focusing on the early 20th century when modern architecture was born. The analysis is guided by the treatise of Beatriz Colomina, *X-Ray Architecture*, presenting an innovative insight towards the relationship among modern architecture, tuberculosis – the medical obsession of the time – and the fascination towards its diagnostic device, the X-ray.

Another significant concept relating architecture to the human body is the act of “cutting”. Anatomical scholarship is based on dissection, or cutting up, of an organism because the continuous and seamless layer of skin covering the corporal space must be overcome in order to obtain the knowledge of the body. As both the

⁹ Colin Rowe and Robert Slutzky, “Transparency: Literal and Phenomenal,” *Perspecta* 8 (1963): 45–54, <http://www.jstor.org/stable/1566901>.

architectural artefact and the human body are enclosed entities with complex interiors, the analytic drive underlying their study involves “cutting” which renders it possible to see through the exterior envelope into the sophisticated depths. In that sense, it becomes possible to say that the conceptual equivalent of dissection is section in architecture.

Every member of the human body is exceptionally customized and autonomously functioning to a certain degree, yet all these individual elements comprise the parts of a complex whole, that works as an excellent system. Therefore, the body has been analyzed, taught and learned piece by piece, in fragments, for centuries. In this respect, the highly utilized and strongly favored study method for the human body “dismembering and re-membering”, makes perfect sense. The disassembly and reassembly of the parts of the body produces the unequivocal corporal knowledge. This study argues that the idea of “dismembering and re-membering” has not only been employed in the anatomical curriculum, the design of the anatomical objects, and the anatomical visualizations but also manifests itself in the space of the anatomy museum. It is asserted that in the museum space, the actual body fragments and their representations come together to create the “idea” of a novel and complete body. In better terms, the dismembered body is “re-membered” in the museum space. In addition, the concept of “remembering” comes to the fore within the context of anatomical display. It is highlighted that remembering, considering its historical connotation as a “learning model” and the ancient practice of the “art of memory”, by relating recalling to the process of knowing, encourages the creation, storing and piercing of knowledge. Within this framework, the term “remembering” is regarded in a dual sense, referring both to the act of gathering the dismantled body parts (re-membering) and the process of recalling (remembering). It is necessary to underline the fact, that the association between these two concepts goes beyond being a mere wordplay, as they are claimed to be semantically related. In a sense, both correspond to the recollection of the related parts of a whole, mentally, or physically.

The extensive research process reveals that architecture have been studied, visualized and represented, yet never been displayed in fragments. Although the display of human body in fragments is a common approach, the idea of displaying architecture in pieces is almost unattempted. Considering the seminal conditions created by the fragmented display of anatomy, this study examines the potentials of implementing this method to the display of architecture. The possible answers to the questions of “How could the display of architecture benefit from the display of anatomy?” and “What could be the contribution of anatomical display methods and approaches to the display of architecture?” are explored within the way of thinking suggested by the discursive concepts of fragmentation and the process of dismembering-remembering. In better terms, this thesis aims to build a bridge between anatomical display and the display of architecture under the concept of “fragments”. In terms of evoking invisible yet, undeniable links between the display of anatomy and the display of architecture, “Elements of Architecture” exhibition designed by Rem Koolhaas for the 14th Venice Biennale is analyzed and discussed in this respect.

CHAPTER 2

ANATOMY MUSEUMS AND THE SPACES AROUND

2.1. The Emergence and Development of the Anatomy Museums

2.1.1. From Cabinets to Museums

“This is a site for close encounters with extraordinary objects: bones, flesh, organs, in display cases, ... Things like this usually belong inside a body, living or dead, or in the cemetery. But here they are, on shelves, trapped behind glass, floating in fluid, or supported by wire armatures. Here, we are invited to view and reflect upon the secret insides of human bodies, things that are at once repulsive and attractive: entrails, dead fetuses, brains in jars..”¹⁰

Anatomy museums are unusual spaces. Unlike other types of museums, they contain very intimate objects; human bodies. Human body as fragmented or whole is displayed together with its representations through diverse visual and textual environments. In the space of anatomy museum all the material related to human body: preserved human remains, texts, drawings, photographs, models and films representing the body come together for the pursuit, dissemination, teaching and practice of anatomical knowledge. For the visitors, the objects displayed in anatomy museums are extremely tempting but repulsive and disturbing at the same time. Being torn between curiosity and uneasiness, the visitors are faced with an extraordinary experience inside these museums.

¹⁰ Eva Åhrén and Michael Sappol, “The Strange Space of the Body: Two Dialogues,” in *Strange Spaces: Explorations into Mediated Obscurity*, ed. Andre Jansson and Amanda Lagerkvist (Farnham: Ashgate Publishing, 2009), 73–100. 88

According to Eva Åhrén, anatomy museums are “heterotopic places”.¹¹ Regarding the definition made by Michel Foucault, heterotopia is a “counter-site, a kind of effectively enacted utopia in which . . . other real sites . . . are simultaneously represented, contested and inverted.”¹² Foucault uses the analogy of mirror while explaining the intrinsic character of a heterotopia:

“I believe that between utopias and these quite other sites, these heterotopias, there might be a sort of mixed, joint experience, which would be the mirror...heterotopia in so far as the mirror does exist in reality, where it exerts a sort of counteraction on the position that I occupy. From the standpoint of the mirror I discover my absence from the place where I am since I see myself over there. Starting from this gaze that is, as it were, directed toward me, from the ground of this virtual space that is on the other side of the glass, I come back toward myself; I begin again to direct my eyes toward myself and to reconstitute myself there where I am. The mirror functions as a heterotopia in this respect: it makes this place that I occupy at the moment when I look at myself in the glass at once absolutely real, connected with all the space that surrounds it, and absolutely unreal, since in order to be perceived it has to pass through this virtual point which is over there.”¹³

In the anatomy museum the visitors enter a space full of bodies which are on one hand not exactly their bodies but on the other hand they are very similar to their bodies. In a sense, behind the glass jars and display cases they see themselves in spite of the fact that they are not there physically. It is a confrontation with the “self”. The visitors see their reflections and reestablish themselves through the bodies behind the glass. The encounter of the visitor bodies with the bodies on display creates the mirror effect mentioned by Foucault, while the space of the anatomy museum becomes a heterotopic site. Furthermore, Åhrén says that:

“Several features of the anatomy/pathology museum fit in with Foucault’s heterotopology. It is a place of (physical) deviation, turning the inside out and displaying corporeal otherness as pathological deformity. It is also a space which has shifted meaning over time. It used to be part of the apparatus

¹¹ Eva Åhrén and Michael Sappol, “The Strange Space of the Body: Two Dialogues,” *Strange Space. Explorations into Mediated Obscurity*, 2009, 96

¹² Foucault, “Of Other Spaces: Utopias and Heterotopias.” 24

¹³ Foucault. 24

by which medical science produced and communicated knowledge, and asserted power over the patient and the dead. Now it is a museum of the history of medicine and of death and grotesquery, a place of leisure.”¹⁴

She underlines two important aspects of anatomy museums epitomizing heterotopia. The chill contact with dead and morbid beings in the space of anatomy museum evokes the strong feelings of otherness, placelessness and monochopsis which is very intrinsic to heterotopic sites. Besides, it is known that the anatomical museum had its heyday as a space for scientific advancement in the late nineteenth and early twentieth century and due to technological developments and updates in medical education it has transformed into a museum of medical/anatomical history and become a place more of novelty, wonder, curiosity and inspiration, fitting into the heterotopia description of Foucault.

As we approach to the third decade of the twenty first century, it is possible to say that human body, specifically its anatomy, is in the limelight. This may be considered as an expression of a new articulated consciousness of the body however, this interest cannot be reduced to an increasing interest towards health as it suggests a more complex motivation behind it. In parallel with this sophisticated interest in human body, anatomy museums and anatomical exhibitions are receiving growing public and academic attention. In the UK, the museums of the two royal surgical colleges in London and Edinburgh have placed human anatomical and pathological specimens at the heart of their visitor offer, to public and critical acclaim. In the US the Mütter Museum of the College of Physicians in Philadelphia is drawing huge crowds, while in Europe the Josephinum in Vienna; the Berlin Museum of Medical History at the Charité; the Musée Fragonard outside Paris and the Vrolik Museum in Amsterdam are testament to the continuing interest in such collections from non-medical audiences. Commercial shows such as Gunther von Hagens' Bodyworlds,

¹⁴ Åhrén and Sappol, “The Strange Space of the Body: Two Dialogues.”, 96

despite public and scholarly criticism, have become common-place visitor attractions.¹⁵

Although it may seem like a newly burgeoning field of interest, the passion and curiosity towards anatomical objects have a long-established history dating back to 16th century. Marking a break with the world-view associated with the Middle Ages, new perspectives were opened up by the discovery of the “New World”. The historical break created a certain group of people in Europe. These people, referred as the “virtuosi” of Renaissance, were the gentlemen with cutting-edge interest in natural history and arts. Their travels created a network of knowledge across the continent. Their collections of natural specimens and cultural artifacts were known as cabinets of curiosities, or *Wunderkammern*. Despite being unsystematic and idiosyncratic in composition¹⁶, curiosity cabinets bear great significance since they have laid the foundations of modern museums that we have today.

The German word *Wunderkammer* is a combination of the term “*wunder*” meaning wonder and “*kammer*” meaning chamber and directly translated as “wonderchamber”. As the word suggests, the concept of “wonder” was essential for the early collections and still maintains its importance for the modern museums of today. Coming from the *Wunderkammer* culture, the “Wow!” factor is a crucial element of museum display. Especially the particular case of anatomy museums, offers an augmented wonder effect to the visitors. This shows that, in addition to the idea of bringing together various objects in a certain order for display, the concept of “wonder” makes *Wunderkammern* the ancestors of modern museums.

What made these cabinets “wondrous” was the collection of objects considered to be worthy of “curiosity” and “wonder” displayed in them. Among those objects, ethnographic articles and natural specimens brought from the *New World* were highly valued. Accommodating a great variety of items, natural, artificial or the

¹⁵ Simon Chaplin, “Review: The Fate of Anatomical Collections, Edited by Rina Knoeff and Robert Zwijnenberg,” *Science Museum Group Journal*, 2016, <https://doi.org/http://dx.doi.org/10.15180/160509>.

¹⁶ Greenhill, Eileen Hooper. *Museums and the Shaping of Knowledge*. London: Routledge, 1992, 79

combination of both, these cabinets were believed to be horizon-opening and thus, fitting perfectly to the epistemic principles of the time.¹⁷

“Amassing in *Wunderkammern* (chambers of wonder) and cabinets of curiosities, was a profusion of things: plants, preserved parts of animals, stones, metals, artefacts, human bodies (and parts thereof) – either in the flesh or in fabricated versions, such as automata...Among further human remains that were highly prized for their perceived rarity and strangeness were mummified heads, foetuses with many limbs and unusual stones from kidneys.”¹⁸

Items of *humana*, which was a term used for both parts and products of the human body were common in the cabinets of curiosities in the 16th and 17th centuries.¹⁹ The inclusion of human substance in the assemblage of curiosity cabinets clearly denotes the very early enthusiasm in collecting anatomical material. These collecting practices creating the curiosity cabinets were undertaken by merchants, lawyers, and scholars as well as physicians and apothecaries. For instance Ole Worm, who is the first great collector in Scandinavia and a phenomenal figure in North European intellectual history in terms of being the local founding father for several modern disciplines, including archaeology, museology, philology, ethnology, and folklore, was a professor of medicine at the University of Copenhagen.²⁰

The great interest of medical professionals in collecting and the fact that curiosity cabinets are considered as premodern museums, there is a deeper connection between the disciplines of medicine and museology than curiosity cabinets just being the ancestors of the anatomy museums. Samuel Alberti uses the term “surgeon-curator” to describe the surgeons, or medical professionals in general, who are interested in collecting practice, have their personal collections of human remains

¹⁷ Valdimar Tr. Hafstein, “Bodies of Knowledge: Ole Worm & Collecting in Late Renaissance Scandinavia”, *Ethnologia Europea* 33, no.1 (2003): 5-20, 6

¹⁸ Elizabeth Hallam and Samuel JMM Alberti, “Bodies in Museums,” in *Medical Museums: Past, Present, Future*, ed. Samuel JMM Alberti and Elizabeth Hallam (London: The Royal College of Surgeons of England, 2013), 1–15. 3

¹⁹ Chaplin, “John Hunter and the ‘Museum Oeconomy’, 1750-1800.” 13

²⁰ Valdimar Tr. Hafstein, “Bodies of Knowledge: Ole Worm & Collecting in Late Renaissance Scandinavia”, *Ethnologia Europea* 33, no.1 (2003): 5-20, 5

and other natural history objects or, in later times, curate the anatomical museums in the institutions of medical teaching.²¹



Figure 1. Ole Worm's museum in Copenhagen from *Museum Wormianum* (1655).

Source: Elizabeth Hallam and Samuel JMM Alberti, "Bodies in Museums," in *Medical Museums: Past, Present, Future*, ed. Samuel JMM Alberti and Elizabeth Hallam (London: The Royal College of Surgeons of England, 2013), 1-15, 2.

To be specific, the first curiosity cabinet which has developed into an anatomy museum is the one owned by the guild of Barber Surgeons of Edinburgh, which later on constituted the Royal College of Surgeons of Edinburgh.²² Towards the end of the fourteenth century, "early Barber-Surgeons carried out their primitive surgery - dressing wounds, arresting bleeding, drawing blood, adjusting fractures and

²¹ Samuel JMM Alberti, "Objects and the Museum," *Isis* 96, no. 4 (2005): 559-71., 563

²² Dawn Kemp and Sarah Barnes, *Surgeons' Hall: A Museum Anthology* (Edinburgh: Royal College of Surgeons, 2009).

extracting teeth.”²³ In 1506, the Seal of Cause of the Barber-Surgeons was approved by James IV and they became one of The Incorporated Trades of Edinburgh.²⁴ After then, the Barber-Surgeons were permitted to dissect one sentenced prisoner each year with the aim of educating their apprentices in anatomy.²⁵ In 1681, the medical doctors who were educated abroad established the Royal College of Physicians of Edinburgh. In 1697, to be able to carry out public anatomical dissections once a year, the Incorporation built their first Hall, known as the Surgeons’ Hall, comprising an anatomical theatre²⁶. The building designed by architect James Smith included a “Great Hall”, a library and a laboratory in addition to the anatomy theatre.²⁷



Figure 2. Surgeon's Hall, Royal College of Surgeons of Edinburgh

Source: J.N.J. Hartley "The Early History of the Museum of the Royal College of Surgeons of Edinburgh." *Edinburgh Medical Journal* 55, no. 9 (1948), 522.

After the construction of the Hall, the Incorporation began to make a collection of books and rarities owned by the College “which formed the nucleus of the

²³ J.N.J. Hartley, “The Early History of the Museum of the Royal College of Surgeons of Edinburgh,” *Edinburgh Medical Journal* 55, no. 9 (1948): 513–32. 513

²⁴ Chris Henry, “Museums Within a Museum,” in *Medical Museums: Past, Present, Future*, ed. Samuel JMM Alberti and Elizabeth Hallam (London: The Royal College of Surgeons of England, 2013), 30–43. 32

²⁵ Hartley, “The Early History of the Museum of the Royal College of Surgeons of Edinburgh.” 513

²⁶ Anatomical Theatres are covered in detail in Chapter 3.

²⁷ “History and Vision,” accessed December 11, 2019, <https://www.rcsed.ac.uk/the-college/about-us/history-and-vision>.

museum.”²⁸ An advertisement was published in the Edinburgh Gazette saying that the Incorporation was asking for natural and artificial curiosities as donations for their collection. The list recording the donations consisted of:

“A large African Gourd, with a silver head ; a case containing ten old German lancets; a large eel skin stuff and taken in Cramond Water ; a pair of Scots cocks spurs clecked in Fife, prodigiously long ; several shells, plants of Spongie marina got in the North of Scotland ; an American Wasps’ nest ; an Allegatory, or young Crocodile.”²⁹

In 1722, the Incorporation of Surgeons officially separated from the Society of Barbers and undertook the task of surgical education which established the reputation of Edinburgh as a center of surgical teaching. In 1778, the title “Royal College of Surgeons of the City of Edinburgh” was given by King George III to the Incorporation. Shortly after the ranking of the Incorporation as Royal College, in a meeting held in October 1804, the idea of establishing a museum comprising “[m]orbid preparations, casts and drawings of diseases”³⁰ was brought up to enhance the surgical education. During the 1820s there was a great expansion of the collections via donations and purchases. Thus, Scottish architect William Henry Playfair was commissioned to design a new building principally to accommodate the expanded collection of the College. In 1832, Playfair Hall, the new home of the College opened.

²⁸ Hartley, “The Early History of the Museum of the Royal College of Surgeons of Edinburgh.” 515

²⁹ Hartley. 516

³⁰ Hartley. 519



Figure 3. Playfair Hall, Royal College of Surgeons of Edinburgh

Source: “RCSEd Archive Catalogue,” accessed October 6, 2020, <https://library.rcsed.ac.uk/about-us/blog/archive/rcsed-archive-catalogue>.

The museum of the Royal College of Surgeons was a “teaching museum”³¹ as defined by Hartley and it was a “primary learning resource”³² for the students of the college. It is important to underline the fact that the museum was not simply considered as a space of display or an archive for the College, instead a learning and teaching environment just like the Lecture Room and the Library in the Playfair Hall. Correspondingly, Hartley refers to the museum as an “instrument of education”³³ in *The Royal College of Surgeons of Edinburgh*.

In its present arrangement, The Royal College of Surgeons of Edinburgh hosts a Pathology Museum, a Surgery Museum and a Dental Collection which are altogether named as Surgeons’ Hall Museums. Although the Museums were initially established as a medical teaching resource with limited access, all are now available for public visit.³⁴

³¹ Hartley.518

³² Henry, “Museums Within a Museum.” 34

³³ Hartley, “The Early History of the Museum of the Royal College of Surgeons of Edinburgh.” 513

³⁴ “History and Vision.”

Another important example is the Bologna Anatomy Museum which is one of the most ancient museums.³⁵ In a similar fashion with many other anatomy museums established in Europe, the Bologna Anatomy Museum developed within the Medical School of the University of Bologna. The birth of the school was around 1288, the period in which the first public anatomical lectures were given. The first building devoted to public anatomy lessons was the Anatomical Theatre built inside the *Archiginnasio*. *Archiginnasio* was the first main building of *the Alma Mater Studiorum Bononiensis* (University of Bologna) which is the oldest university in the Western world. The building designed by Antonio Morandi was inaugurated in October 1563. In 1638, the erection of the Anatomy Theatre inside *Archiginnasio* was initiated and the theatre began to function in 1639.³⁶ The Anatomy Theatre was extended many times and improved until 1737.

At the end of 17th century, the University suffered from a cultural crisis depending on the dogmatism of the public teaching³⁷. To compete with the University, many private academies were established in Bologna in the fields of Arts, Philosophy and Sciences. The most well-known one was the Academy of Sciences which was founded to revive the interest to scientific observation and experimental research in all fields of natural sciences. The institution was located in *Palazzo Poggi*. Inside the *Palazzo* “each branch of natural sciences was represented in a *cabinet*, where specimens, machines, and designs were exhibited and used for experimental training.”³⁸ The Cabinet of Anatomy was one of them. In addition to the exhibition rooms, the Cabinet contained dissection and modelling rooms which engaged the practical training with display environments to enhance medical studies.³⁹

³⁵ Nadir M. Maraldi et al., “Anatomical Waxwork Modeling: The History of the Bologna Anatomy Museum,” *The Anatomical Record* 261, no. 1 (2000): 5–10. 5

³⁶ Giovanna Ferrari, “Public Anatomy Lessons and the Carnival: The Anatomy Theatre of Bologna,” *The Past and Present Society*, no. 117 (1987): 50–106, <http://www.jstor.org/stable/650788>. 50

³⁷ Maraldi et al., “Anatomical Waxwork Modeling: The History of the Bologna Anatomy Museum.”5

³⁸ Maraldi et al.6

³⁹ Franco Dicesare, “L’Architettura Dell’Illusione a Palazzo Poggi” (University of Bologna, 2018).

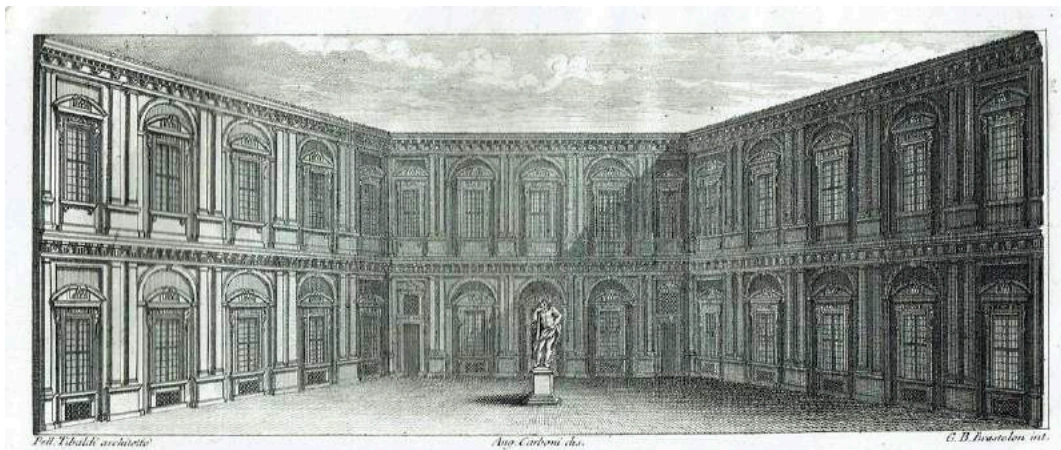

Figure 4. Engraving representing the internal courtyard of Palazzo Poggi by Giovanni Battista Brustolon, 1756
 Source: Franco Dicesare, “L’Architettura Dell’Illusione a Palazzo Poggi” (University of Bologna, 2018). 13

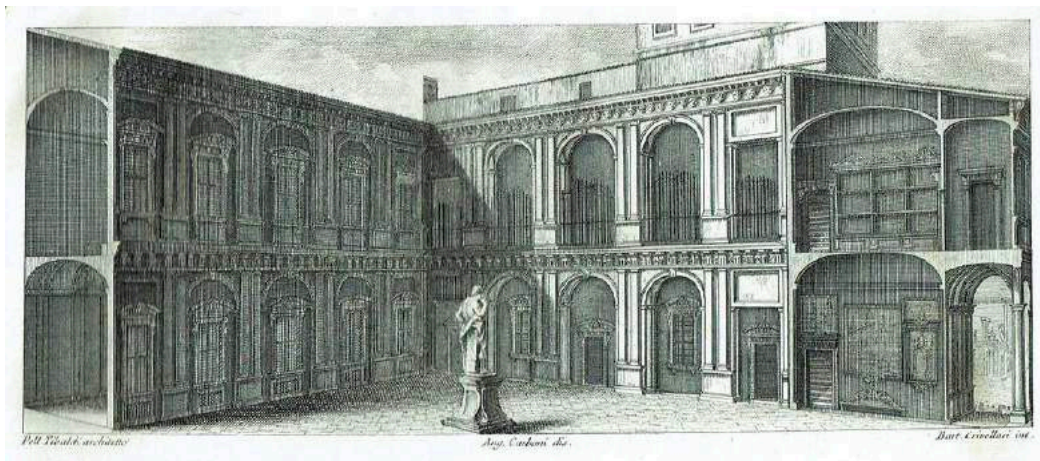

Figure 5. Engraving representing the internal courtyard of Palazzo Poggi by Bartolomeo Crivellari, 1756
 Source: Franco Dicesare, “L’Architettura Dell’Illusione a Palazzo Poggi” (University of Bologna, 2018). 13

The Anatomical Chamber initially received a small collection of dry specimens (mummified parts of the cadavers) to be used for the purpose of medical education. Due to the extensive use of the collection as a teaching instrument, the specimens got deteriorated which created the need for anatomical models made from durable materials. The first models, eight statues and individual bones and muscles, made from clay, wood and wax by the painter Ercole Lelli, constitute the early collection of the Bologna Anatomy Museum. After the death of Lelli in 1766, his work continued by the anatomy teacher Anna Morandi. Later on, the collection was further

extended between 1789 and 1815 with the incorporation of the wax models made by the well-known model artist Clemente Susini.⁴⁰



Figure 6. A view of Ercole Lelli's anatomy room, realized for the Bolognese Institute of the Sciences.

Source: Lucia Dacome, "Waxworks and the Performance of Anatomy in Mid-18th-Century Italy," *Endeavour* 30, no. 1 (2006): 29–35, <https://doi.org/10.1016/j.endeavour.2006.01.004>. 30

Most of the anatomy museums in Europe have emerged in public institutions devoted to medical teaching as seen in the cases of The Museum of The Royal College of Surgeons of Edinburgh and Bologna Anatomy Museum. Despite that, Hunterian Museum in London exemplifies another development model of anatomy museums.

During the Georgian Period in Britain, which corresponds to the second half of the 18th century, although some lecturers worked within hospitals, most anatomy teaching took place in domestic or commercial spaces. Lecturers such as William Hunter and his brother John Hunter "were effectively operating on their own accounts, often in their own homes, and without any kind of institutional framework to legitimise their work."⁴¹

During the late eighteenth century, the center of British medical education shifted from Edinburgh to London. Based upon that, William Hunter, born and trained in

⁴⁰ Maraldi et al., "Anatomical Waxwork Modeling: The History of the Bologna Anatomy Museum."

⁴¹ Chaplin, "John Hunter and the 'Museum Oeconomy', 1750-1800." 38

Scotland moved to London for professional accomplishment. He became a member of the Royal Society in 1767 and was assigned professor of anatomy to the Royal Academy in 1768. He established the Great Windmill Street School of Anatomy in 1769 and became doctor to Queen Charlotte.⁴² William's younger brother John, whose collection formed the core of Hunterian Museum in London, learned the art of dissecting and the methods for preserving body parts as preparations from him.⁴³ If the late 18th century was the heyday of the London anatomists, it was also a time of exceptional enthusiasm in anatomical collecting.⁴⁴

The development of the anatomical museum as a distinct architectural form was closely related to the teaching of anatomy through dissection in domestic settings. The cases of two well-known museums, those of William and John Hunter support this argument. The collections of William and John were referred to as museums after the completion of their anatomy schools comprising their residences in Great Windmill Street and in Leicester Square, respectively.⁴⁵

William Hunter donated his entire collection to Glasgow University which formed the basis of the Hunterian Museum in Glasgow opened in 1807 while John Hunter's collection was bought by the government for the establishment of Hunterian Museum at the Royal College of Surgeons of England in London in 1799. Although neither of the buildings in Great Windmill Street and Leicester Square house the Hunterian Museum today, those edifices and their spatial layout are extremely important to understand the emergence of anatomy museum as an individual architectural space and the relationships between anatomical teaching, dissecting, collecting and display.

In 1763 William Hunter presented a petition including a model plan to the government requesting support for a new national academy for the teaching of

⁴² Carin Berkowitz, "Systems of Display: The Making of Anatomical Knowledge in Enlightenment Britain," *The British Journal for the History of Science* 46, no. 3 (2013): 359–87, <https://www.jstor.org/stable/43820403.363>

⁴³ Chaplin, "John Hunter and the 'Museum Oeconomy', 1750-1800." 30

⁴⁴ Chaplin.95

⁴⁵ Chaplin.171

anatomy and surgery. The plan shows a rectangular plot including a house of three rooms, theatre, museum, and library. Chaplin describes the schematic plan as:

“It shows a rectangular plot seventy-one feet wide by 112 feet deep. Within this is a square ‘house of three rooms’ (on the ground floor), and adjoining it with its end facing onto the front of the plot a ‘Museum and Library’. The museum in turn connects, via a lobby, with a large square building containing a circular theatre forty-seven feet in diameter, and adjoining this in the far corner of the plot are a ‘coach house and stables’. The buildings form a C-shaped enclosure around two open areas: a large yard behind the house, and a smaller plot alongside the theatre and coach-house designated on the plan as a ‘Burying-ground of Theatre yard’. The latter was presumably a space for disposing of human remains from the dissections...”⁴⁶

The “ideal scheme” that Hunter imagined for his academy reveals the significance of spatial organization for anatomical teaching and underlines the important role of the museum within the anatomy school.⁴⁷ A few years later, Hunter found the opportunity to realize his ideal plan. In 1767 William Hunter decided to move to Great Windmill Street and establish an academy at the very same plot reflecting his ideal scheme in the design for the property. Most probably his decision stemmed from the necessity to accommodate his growing collection of anatomical preparations, minerals, artworks and other kinds of objects. Hunter’s interest towards the architecture of the spaces for anatomical teaching and display was not limited to the design of an ideal scheme for his academy. He also owned vast number of books comprising illustrations and texts of built or imagined anatomical theatres, museums, libraries and other didactic spaces.⁴⁸

⁴⁶ Chaplin.174

⁴⁷ Chaplin.176

⁴⁸ Chaplin.176-177

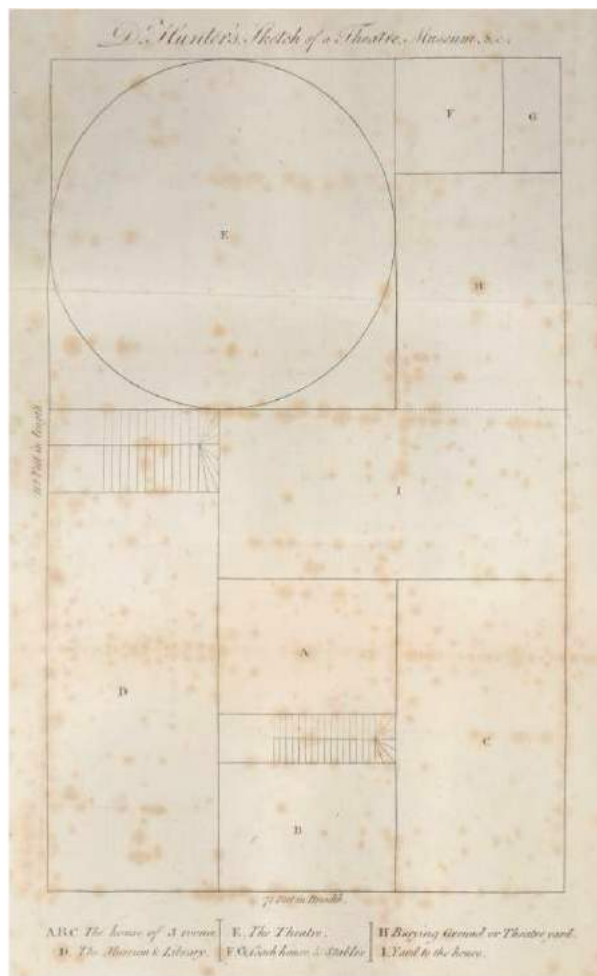

Figure 7. Dr. Hunter's Sketch of a Theatre, Museum, etc. published as part of the appendix to William Hunter's *Two Introductory Lectures* (1784)

Source: Simon Chaplin, "John Hunter and the 'Museum Oeconomy', 1750-1800" (PhD Thesis, King's College London, 2009).175

Although the idea for the plan of the academy came from William Hunter, the implementation of the "ideal scheme" was handled by the architect Robert Mylne (1733-1811). Mylne designed a building that was both practical and stylish, corresponding well to Hunter's thriving status as a connoisseur of the arts and man of science. The plan drawing of Mylne for Great Windmill Street presents how Hunter's ideal plan was translated into reality.⁴⁹

⁴⁹ Chaplin.177

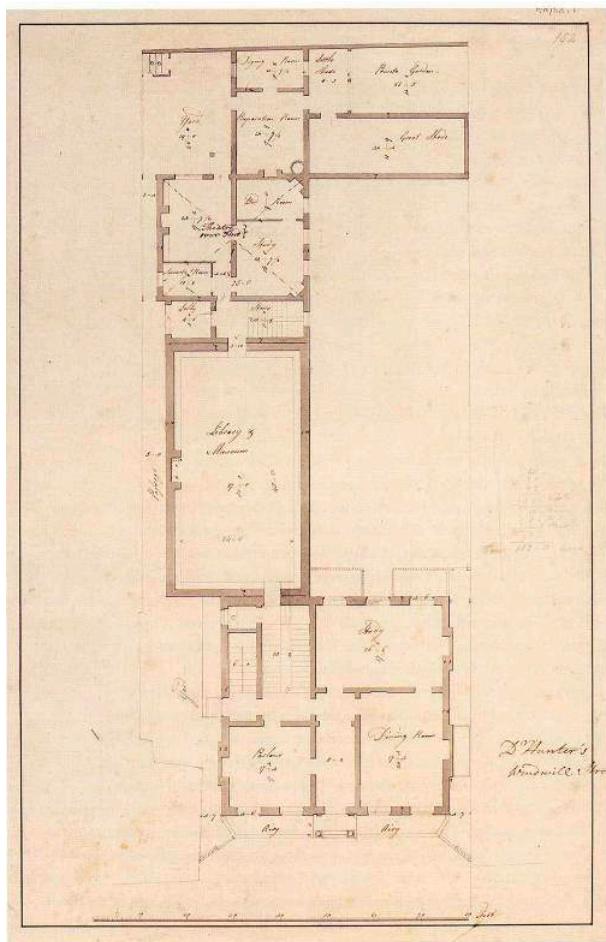

Figure 8. Ground floor plan of William Hunter's house, museum and anatomy school at Great Windmill Street, by Robert Mylne, c.1765-1767

Source: Simon Chaplin, "John Hunter and the 'Museum Oeconomy', 1750-1800" (PhD Thesis, King's College London, 2009).178

The building complex designed by Mylne consisted of three major spaces, house, museum-library and anatomy school. The house had a basement and three stories above, with three rooms on the ground floor. Behind the house there was a long rectangular structure comprising museum and library. The house and the museum were connected at ground floor level. An elliptical gallery ran around the perimeter of the museum, supported by classical pillars, and following the outline of a domed ceiling with oval lanterns. The anatomical department was located at this gallery. The arrangement of the collections was quite interesting since the space dedicated for the collections during the design process, museum-library building, could not

suffice for all the objects, resulting in their dispersion all over the place. The lower part of the gallery was filled with the comprehensive library and the medals and minerals collections. The entire collection of Hunter could not be harbored in the museum building, therefore by 1782 his collections of shells and zoophytes, stuffed birds and quadrupeds were disposed in the rooms at the upper floor of the house. The rest of his collection including his paintings was dispersed throughout the building.⁵⁰ It is possible to say that the collections overflowing from the museum building turned the entire building complex into a display space.

Chaplin underlines three major aspects that are relevant for understanding the house and school of John Hunter in Leicester Square. Two of them are extremely important as they concern the organization and the continuity of the spaces within the building complex. First one is the way architectural structure delineated functional areas within the house. Different functions such as living, exhibiting, lecturing and dissecting were assigned to different parts of the property. These activities were connected to each other in a linear way. At one end there was William Hunter's house with private spaces such as bedrooms and guestrooms, at the other there were the "anatomical spaces" designed for the use of Hunter and his pupils. In this scheme the museum was located between the house and the anatomical spaces. This means that the role assigned by Hunter to the museum, as a building separate from but connecting the teaching and domestic spaces, suggests a significance which went beyond its practical utility as a repository for books and specimens, giving the museum a "liminal quality as a boundary space"⁵¹. Second one is the use of objects as a way of linking the spaces and activities in the house. Due to their penetration into the other parts of the building complex, the collection objects created a visual continuity.⁵²

Considering the aspects mentioned above and many others, the house and anatomy school of John Hunter in 28 Leicester Square was remarkably similar to that of

⁵⁰ Chaplin.180

⁵¹ Chaplin.181

⁵² Chaplin.181

William Hunter in Great Windmill Street. There are no complete architectural plan drawings of John Hunter's house that have survived until today but, a sketch plan showing the ground floor layout of the site as it was in 1792 made by William Clift in 1832 and an unknown surveyor's drawing, attributed to George Byfield, of the ground and the first floors of the museum and Castle Street buildings provide significant information. Together with other records, these plans have been taken as reference for the section perspective drawing of John Hunterian's property prepared by the designer John Ronayne for the Hunterian Museum in 2005.⁵³

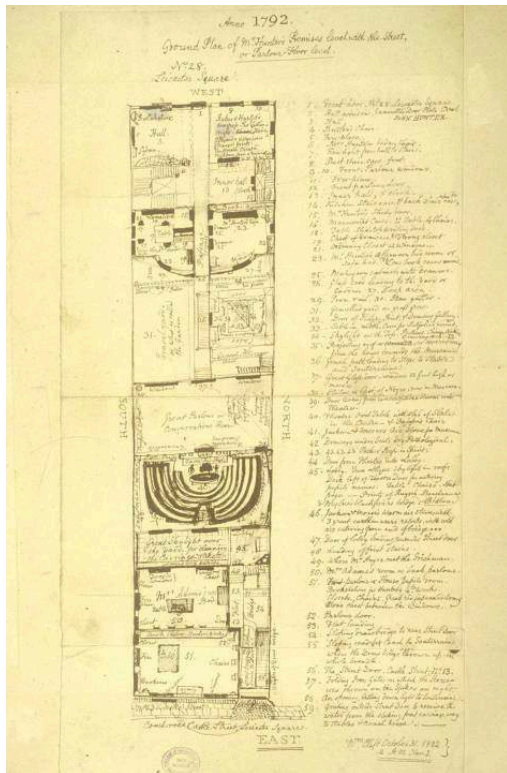

Figure 9. Sketch of the ground plan of John Hunter's house and anatomy school at Leicester Square in 1792 by William Clift, 1832

Source: Simon Chaplin, "John Hunter and the 'Museum Oeconomy', 1750-1800" (PhD Thesis, King's College London, 2009).184

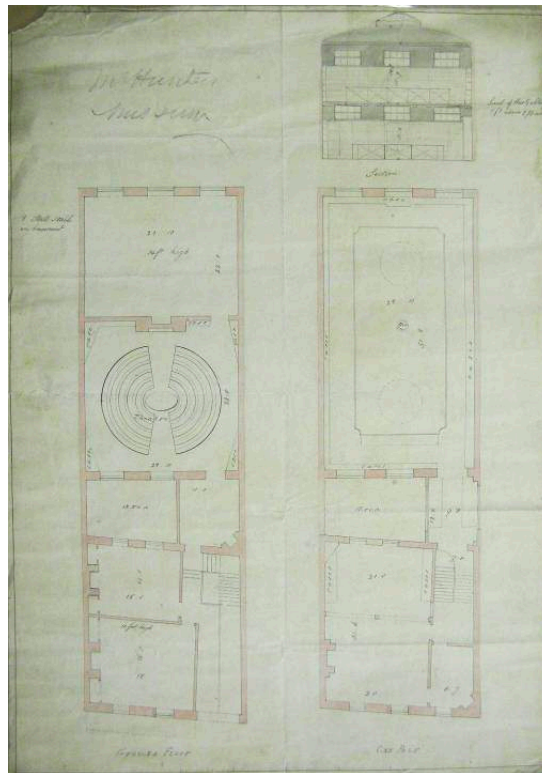

Figure 10. Ground and first floor plans of John Hunter's museum and house in Leicester Square, attributed to George Byfield, probably c.1801

Source: Simon Chaplin, 185

⁵³ Chaplin.182-185

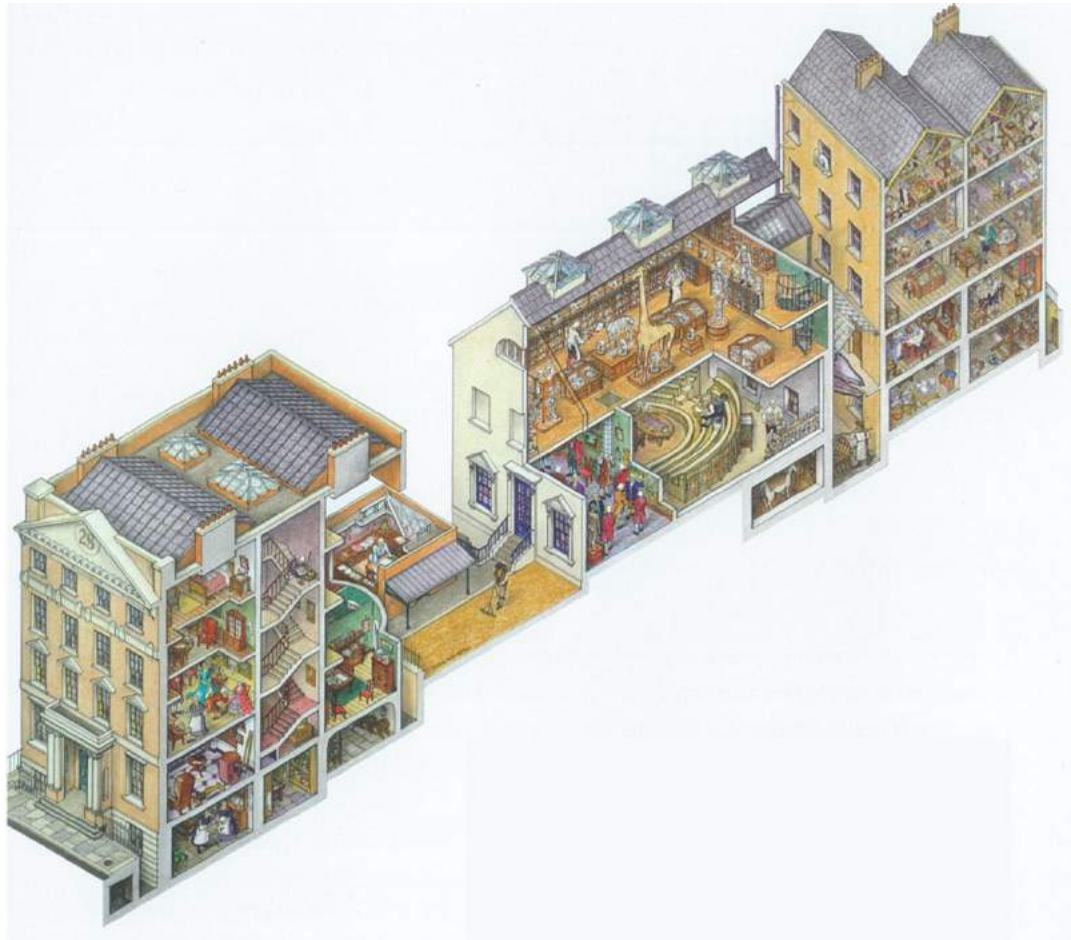

Figure 11. Section perspective view of John Hunter's house, anatomy school and purpose-built museum at Leicester Square, London in 1792 made by John Ronayne, 2005

Source: Samuel JMM Alberti, "The Organic Museum: The Hunterian and Other Collections at the Royal College of Surgeons of England," in *Medical Museums: Past, Present, Future* (London: The Royal College of Surgeons of England, 2013), 16-29, 18.

Regarding the scope of the design and construction work, John Hunter must have gotten the professional input of a trained surveyor or an architect. Possible candidates are Robert Mylne and George Richardson but there are no records showing their direct participation in the building work. Despite that, the design of the property in Leicester Square shows the influence of Mylne's plan for Great Windmill Street and reflects the style of Richardson in interior design.⁵⁴

⁵⁴ Chaplin.190

The first space encountered by guests was the receiving room on the ground floor. Behind the receiving room a larger inner hall gave access to a main staircase on one side of the house, and a servants' staircase on the other. A passage ran from the center of the house to the back, and exiting in the center of a semicircular bay. At both sides there were rooms used by Hunter as study rooms, bedroom or personal library. In these rooms, at night, Hunter was instructing their assistants using the preparations brought from the museum. Unlike his brother William, John Hunter did not have an extensive display of collected books and manuscripts, he only had a modest library consisting of books for practical use. There is no exact information regarding the other storeys, but first floor was probably the main social space of the house. A long drawing room ran the full width of the house at the front. There were paintings hung on the walls of the passageways and the receiving room. Numerous other objects were displayed in the rooms and hallways of the ground and first floor.⁵⁵

John Hunter's property in Leicester Square is described by Chaplin as follows:

Picture gallery

Behind 28 Leicester Square there was a yard with a central pathway leading from the rear door of the house. On the north side of the path there was a tiny, single-storey, windowless building illuminated by a central lantern with a doorway opening to the path. Although it was a separate structure, it was connected to the main house at basement level. The room was used as a picture, print and drawing gallery. Mainly the building was used as a repository for the prints of Hunter but it also included art objects and paintings hung on the walls. In addition to serving as a storage space and a picture gallery, the artists employed for making the drawings of the specimens were working in that building.⁵⁶

⁵⁵ Chaplin.191-194

⁵⁶ Chaplin.194

The Conversazione Room

Next to the picture gallery there was a larger building occupying the full width of the plot. At the basement there were stables enough to accommodate eight horses. There were two main floors above ground. On the ground level there were two rooms. The smaller room at the end of the building is described in Clift's plan as a "Conversazione Room" which was used for the meetings of the Society for the Improvement of Medical and Chirurgical Knowledge and Lyceum Medicum Londinense founded by Hunter and his colleagues.⁵⁷

Lecture Theatre

In the north-eastern corner of the conversazione room a door led through into a larger room which was the lecture theatre. The theatre was used by John Hunter for giving lectures on surgical principles. It included two semi-circular sets of tiered seats on iron frames, a large oval table, a wooden chair for the lecturer and a wooden board or table for the display of preparations during the lectures.⁵⁸

Museum

The museum was located above the conversazione room and the theatre. It was a two-storey structure running the full length and width of the building with a domed ceiling with two circular lanterns. On both levels the walls of the museum were lined with open shelves displaying the preparations of comparative anatomy. The arrangement of the preparations was recorded by the sketch drawing prepared by William Clift.

⁵⁷ Chaplin.195

⁵⁸ Chaplin.195

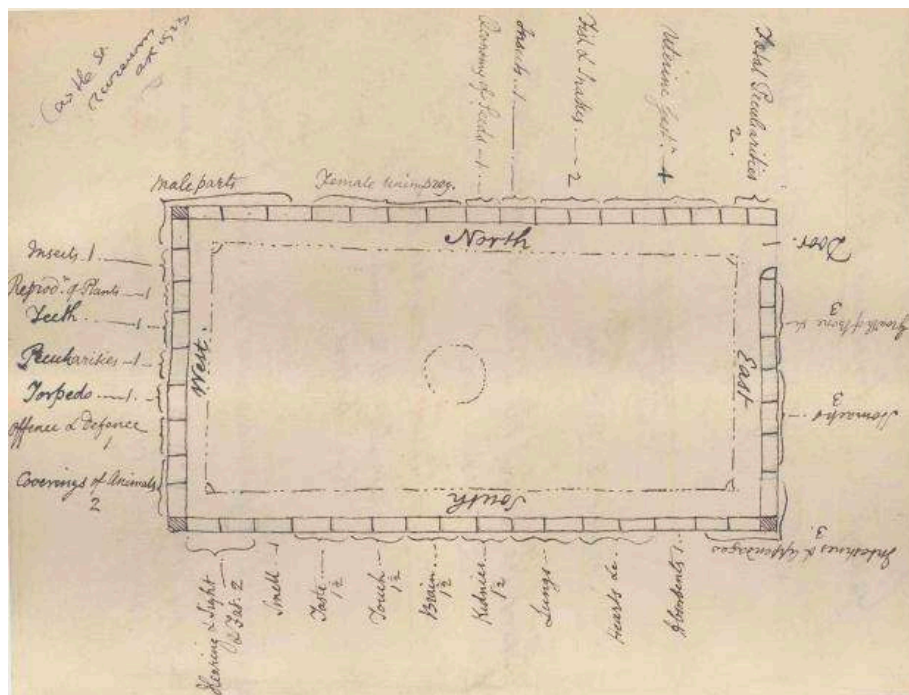

Figure 12. Sketch showing the display layout of the museum prepared by William Clift in 1806

Source: Simon Chaplin, "John Hunter and the 'Museum Oeconomy', 1750-1800" (PhD Thesis, King's College London, 2009).185

The sketch shows that the preparations were classified according to physiological function, resulting in the grouping of human, animal and sometimes plant material together. The cases around the gallery contained fragile internal casts made in wax or metal of organs such as the lungs. The gallery cases also contained John Hunter's specimens of undissected animals preserved in alcohol. In addition to the shelves/cases on the wall, the main floor of the museum was filled with free-standing desk cases with animal skeletons attached on top. Different from William, John Hunter did not use the museum space to display portraits or busts of physicians, art objects, antiquities or ethnographic objects.⁵⁹

⁵⁹ Chaplin.196-199

13 Castle Street

The Castle Street building was a terraced house having one basement and four above-ground storeys. On the first floor there was a lobby wide enough to accommodate large cabinets holding calculi collection of Hunter. Next to the lobby, there was a yard with a whale skull on display. On the third floor there was the dissecting-room illuminated from above. Below the dissecting room there was a workshop space for making the preparations and a bedroom for Hunter's students. Originally the preparation room was on the first floor below, but in 1792 it has been modified to create an extension to the museum for the display of fossil and coralline collections. Hunter's own printing press was located in the basement.

Regarding the spatial organization of John Hunter's property, Chaplin says that:

“Like William Hunter's Great Windmill Street plan, the arrangement of John Hunter's house reveals the degree to which apparently antithetical activities were accommodated through a system of architectural delineation.”⁶⁰

As well described by Chaplin, for comfort and practical reasons the activities of dwelling, teaching, displaying, dissecting, preparation-making, storing were delineated and separated through architectural elements. The physical separation of the house and the dissecting room is especially important. The idea of locating the dissecting room at the rear part of the building to prevent the coming and going corpses disturbing the neighborhood and the household was a common strategy used in 18th century London.⁶¹ On the other hand, the associated activities were visually and spatially connected in the Leicester Square building. The spaces devoted to interrelated functions were linked through stairs and hallways, creating a spatial continuity.

Thomas Markus argues that the architectural scheme of the properties of William and John Hunter illustrates the spatial dependence of Hunters' work as anatomist and collector upon the organization of medical/anatomical knowledge in the museum. According to Markus, the ordered hierarchy of the spaces is related to the

⁶⁰ Chaplin.200

⁶¹ Chaplin.202

hierarchical system established within the museum and library for the classification and ordering of the collections. He also asserts that the overlap of the spatial and natural order enhanced the position of the curator-anatomist in terms of linking the microcosmic scale of the dissected body and the macrocosmic divine architecture of the nature.⁶² The concepts of microcosm and macrocosm and their connection is further explained in Chapter 3.

Unlike the clean lines of the architectural plans drawn by Mylne for the property of William Hunter at Great Windmill Street, Clift's sketch depicting the house and academy of John Hunter gives a dynamic impression. His drawing reflects the fluid relations with multiple meanings between the spaces, activities and objects. Throughout the time Leicester Square building was owned and used by John Hunter, structural alterations, addition, removal and translocation of objects, entering and exiting visitors enhanced this dynamic layout.⁶³

The concept of combining the domestic accommodation with the spaces of anatomical teaching was very common during the 18th-19th centuries in the medical milieu of London. Apart from the properties of William and John Hunter, Andrew Blackall's anatomical theatre in Thavie Inn also combined domestic settings with the spaces for anatomical teaching and dissecting.⁶⁴

Among the spaces of anatomical teaching John Hunter emphasized the role of the museum. In a syllabus he prepared for his lectures on the principles of surgery published in *European Magazine* in 1782, he presented a clear approach regarding the use of anatomical collections as teaching material.⁶⁵

By the time of John Hunter's death in 1793 his collection comprised over seventeen thousand objects including preparations of human and animal anatomy and pathology, collections of fossils, shells and other objects of natural history, paintings,

⁶² Thomas A. Markus, "Domes of enlightenment: Two Scottish university museums." *Museum Management and Curatorship* 4, no. 3 (1985): 215-242. quoted in Chaplin.200

⁶³ Chaplin.200

⁶⁴ Chaplin.202

⁶⁵ Chaplin.112

prints and drawings. The entire collection is now exhibited in the Hunterian Museum at the Royal College of Surgeons of England in London which has a prominent role in the British museum landscape and high prestige among the medical museums around the world. In addition to John Hunter's contribution to the medical history and collecting culture with his extensive collection, also his museological work is unprecedented. David Murray wrote regarding the ideas of Sir William Flower (1831- 1899) who was the conservator of the Hunterian Museum between 1861-1884:

“...John Hunter is to be regarded as the founder of the modern museum, the distinguishing features of which are specialisation and classification.”⁶⁶

The first edifice of the Hunterian Museum at the Royal College of Surgeons of England in London was designed by George Dance and Nathaniel Lewis. Due to the issue of space inadequacy, the building was redesigned by Charles Barry. After the implementation of the new design the museum reopened in 1837. In 1852 an extension was built since the collection kept growing. Between 1888-1892 two other galleries were added following the style of Barry. In total the five galleries were numbered I-V. Other than these exhibition galleries two additional rooms were also used as workshops and display spaces. The areas used to exhibit growing collection of surgical instruments and items such as mummies and other objects apart from the main collection series.⁶⁷

⁶⁶ David Murray, *Museums, Their History and Their Use* (Glasgow: James MacLehose and Sons, 1904). quoted in Chaplin, “John Hunter and the ‘Museum Oeconomy’, 1750-1800.”¹⁰

⁶⁷ “History of the College Museums,” accessed October 7, 2020, <https://www.rcseng.ac.uk/museums-and-archives/hunterian-museum/about-us/history/>.



Figure 13. Room I of V of the Hunterian Museum, around 1900.

Source: Samuel JMM Alberti, "The Organic Museum: The Hunterian and Other Collections at the Royal College of Surgeons of England," in *Medical Museums: Past, Present, Future* (London: The Royal College of Surgeons of England, 2013), 16-29, 21.

A major addition to the museum built in 1909 when the College received on loan the collection of the Odontological Society of Great Britain which included a new gallery under the existing Room II. In 1921 further underground extensions were made for the inclusion of Army Medical Collection. In 1925 another underground extension is made for osteological series below Room I.⁶⁸

The building was bombed in 1941 and the Rooms IV and V were completely destroyed and Room III was partially demolished. The Odontological Collection, located in the basement survived but other parts of the basement were damaged, resulting in the partial loss of the Hunterian Collection. During the reconstruction process after the war considering the damage the collection took, the new edifice built in a different form. The Odontological collection and the modern teaching/research collections were placed in separate buildings. The latter were

⁶⁸ "History of the College Museums."

created as three, then reduced to two museums funded by the Wellcome Trust, which became known as the Wellcome Museums of Anatomy and Pathology respectively.⁶⁹

The new Hunterian Museum, in a lessened form and once again re-centred around John Hunter's original collection, was opened in 1963. Although it had some features of the pre-war design; one could say that it is totally a new building. In 2003 the Hunterian and Odontological Museums were also merged forming the new Hunterian Museum in 2005. In 2017 the museum has closed again for refurbishment. The new display will emphasize the relations between John Hunter, the specimens and the history of the Company and College of Surgeons.⁷⁰

⁶⁹ "History of the College Museums."

⁷⁰ "History of the College Museums."



Figure 14. The larger of the two galleries that comprised the Hunterian Museum in 1842. Watercolor by Tomas H. Shepherd.

Source: Samuel JMM Alberti, “The Organic Museum: The Hunterian and Other Collections at the Royal College of Surgeons of England,” in *Medical Museums: Past, Present, Future* (London: The Royal College of Surgeons of England, 2013), 16-29, 20.



Figure 15. The “Crystal Gallery” in the 2005 refurbishment of the Hunterian Museum

Source: Alberti, 28.

2.1.2. The Status of Museum Architecture and the Anatomy Museum Today

After exploring the emergence of anatomy museums in terms of unfolding the establishment processes of three prominent museums, The Museum of the Royal College of Surgeons of Edinburgh, Bologna Anatomy Museum and the Hunterian Museum at the Royal College of Surgeons of England in London, from an architectural point of view, it is important to understand the status of anatomy museums among other museum types in the architectural milieu today.

Sophie Forgan argues that “museums are complex sites, standing at the intersection of scientific work and display”⁷¹. Recent studies have discussed different aspects of museums, such as their role in public and academic education, the manners they contribute to the shaping of knowledge, their position in urban context and civic life and its manifold social, economic and cultural functions. The studies of museums and their histories constitute a field that embraces many disciplines and relates to various discourses. Among museum-related studies, subjects and discussions, “museum architecture” comes to the fore regarding its growing social, economic and, cultural impact for centuries, especially more recently.

“Buildings are artefacts in themselves, reflecting the intellectual and material context of the society in which they were founded.”⁷²

Buildings are a reflection of the ideas, mindsets and circumstances that create them. They cannot be understood or studied without knowing the context they were produced. They are highly related to the society in which they were designed and erected. The relation of buildings to their context is not one-way. As the intellectual and the material environments affect architecture, architecture affects them reciprocally. Forgan claims that “buildings have enormous transformative potential”⁷³. Her statement underlines the power of architecture for shaping the society, altering the intellectual mindset and restructuring the social and financial paradigms. In that sense, it becomes necessary to examine the contemporary role of museum buildings as artefacts in urban context and their influence on social, cultural and economic areas. Then, evaluate the particular case of anatomy museums within this context.

⁷¹ Sophie Forgan, “Building the Museum Knowledge, Conflict, and the Power of Place,” *Isis* 96, no. 4 (2005): 572–85, <http://www.jstor.org/stable/10.1086/498594>. 572

⁷² Brigitte Schroeder-Gudehus, “Patrons and Publics: Museums as Historical Artefacts,” *History and Technology, an International Journal* 10, no. 1 (1993): 1–3. quoted in Forgan, “Building the Museum Knowledge, Conflict, and the Power of Place.” 572

⁷³ Forgan, “Building the Museum Knowledge, Conflict, and the Power of Place.” 572

“What a strange time we live in: museums are turning into churches, and churches into museums!”⁷⁴

In recent times, museums have been scholarly and socially characterized as “ritual spaces” due to the enactment of multifold civilizing and spiritually satisfying activities taking place in them. In modern museums facilities such as quiet spaces, sitting areas leading to musing, tearooms, or even sculpture gardens for reflective meditation demonstrate the role of museums as ritual spaces, replacing the canonical religious edifices.⁷⁵ Besides that, there is another important, maybe more visible, aspect which may have caused Jean Cocteau to compare the museum buildings with churches and led him think that museums were becoming churches. For many centuries religious buildings were erected to be the most spectacular, iconic and monumental structures of the towns and big cities but today, museum buildings are upstaging the iconic religious buildings with their eye-catching architecture.

During the Enlightenment, the shifting attention from religion to other notions such as politics, culture, art and science, the iconic buildings of the cities began to be edifices other than churches. In the second half of 18th century, museums began to be constructed as monumental edifices, or transformed from existing iconic structures, in metropolitan cities, like Louvre Museum (1793) in Paris, British Museum (1753) in London and Rijksmuseum (1798) in Amsterdam.

⁷⁴ Jean Cocteau quoted in Arthur Gillette, “Museum Architecture: Beyond the ‘Temple’ and... Beyond,” *Museum International* 41, no. 4 (1989): 247–56.

⁷⁵ Forgan, “Building the Museum Knowledge, Conflict, and the Power of Place.” 582

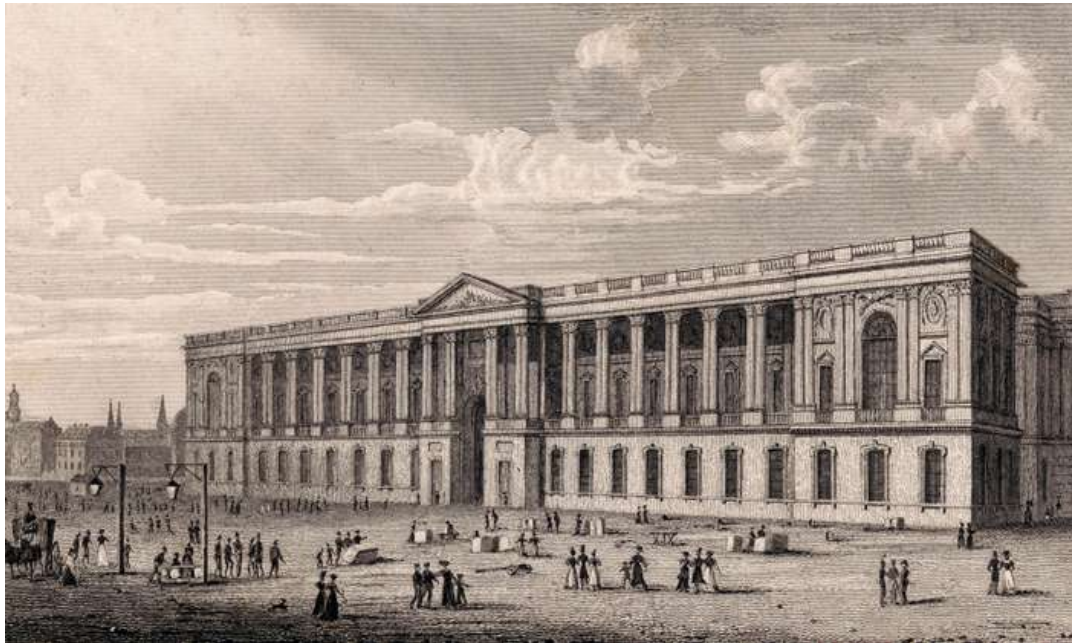

Figure 16. The eastern facade of the Louvre Museum, Paris, 19th-century print.

Source: “Louvre,” in *Britannica*, accessed October 7, 2020, <https://www.britannica.com/topic/Louvre-Museum>.

In addition to iconic museum buildings “museum islands”, districts that include multiple museums and cultural institutions, were built such as *Museuminsel* in Berlin and South Kensington in London. Especially, *Museumsquartier* in Vienna was designed as a part of the formal urban design aiming to enhance the city and impress the visitors with the magnificence of clustered museum buildings underlining significance of the institutions housed by them. In a way all these grandiose buildings were representatives of authoritative nature and the power of knowledge. Forgan claims that “the respectability of institutional buildings,...lends credibility to the knowledge embedded within museum displays and activities.”⁷⁶ This underlines the relationship between the authority of the institution, the reliability of the knowledge produced, disseminated and preserved by these institutions, and the grandeur architecture of the museum building.

⁷⁶ Forgan. 580



Figure 17. Museumsquartier Vienna

Source: "MuseumsQuartier Wien," accessed October 8, 2020, <https://www.mqw.at/en/about-us/>.

In 20th century the trend of making spectacular museum buildings developed and transformed into a statement in architectural discipline. Museum design has become a special field in architecture which enables and promotes architects to show their architectural skills, play with different forms and experiment with new materials.

A pioneering example of this condition is the Solomon R. Guggenheim Museum in New York, designed by the architect Frank Lloyd Wright and built between 1956-1959. The circular form of the museum building was very unusual for its time. The idea of concave exhibition niches surrounding a central spiral accompanied with a ramp connecting the stories was considered as a daring approach when compared with the traditional definition and perception of a museum space. The extraordinary design of the museum initiated intense arguments among architects, critics, artists and public.

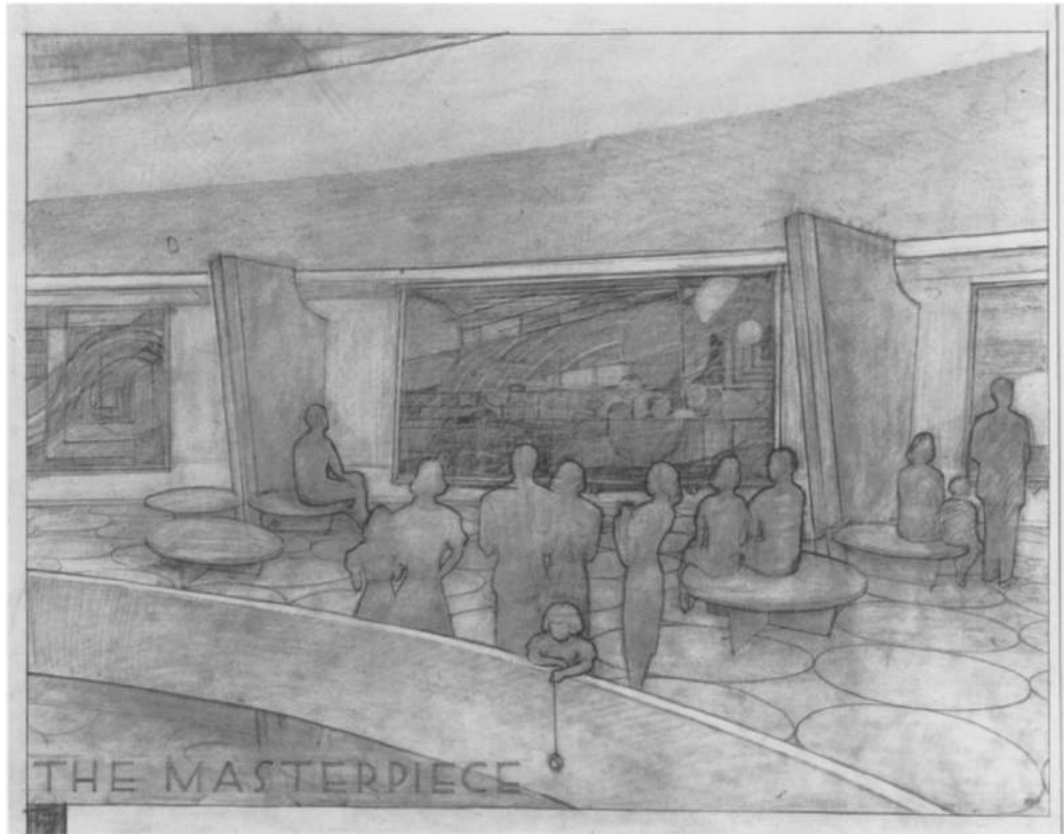

Figure 18. Interior perspective drawing of R. Solomon Guggenheim Museum by Frank Lloyd Wright, "The Masterpiece," 1958.

Source: Jack Quinan, "Frank Lloyd Wright's Guggenheim Museum: A Historian's Report," *Journal of the Society of Architectural Historians* 52, no. 4 (1993): 466–82, <https://www.jstor.org/stable/990869>. 467

The building had an unconventional form breaking the taboos of the canonical museum architecture and it was disharmonious with the grid plan of the city. Before the opening of the museum, twenty-one artists signed a letter protesting the display of their work in such a space. In addition, historian Lewis Mumford harshly criticized the building in his article published in 1959 in *The New Yorker* saying that "[Wright] created a shell whose form had no relation to its function and offered no possibility of any future departure from his rigid preconceptions."⁷⁷ All these reactions to the

⁷⁷ Lewis Mumford, "What Wright Hath Wrought," *The New Yorker*, 1959, <https://www.newyorker.com/magazine/1959/12/05/what-wright-hath-wrought>.

building underline the fact that it was an innovative approach to museum design foreshadowing the birth of a new culture in architecture.

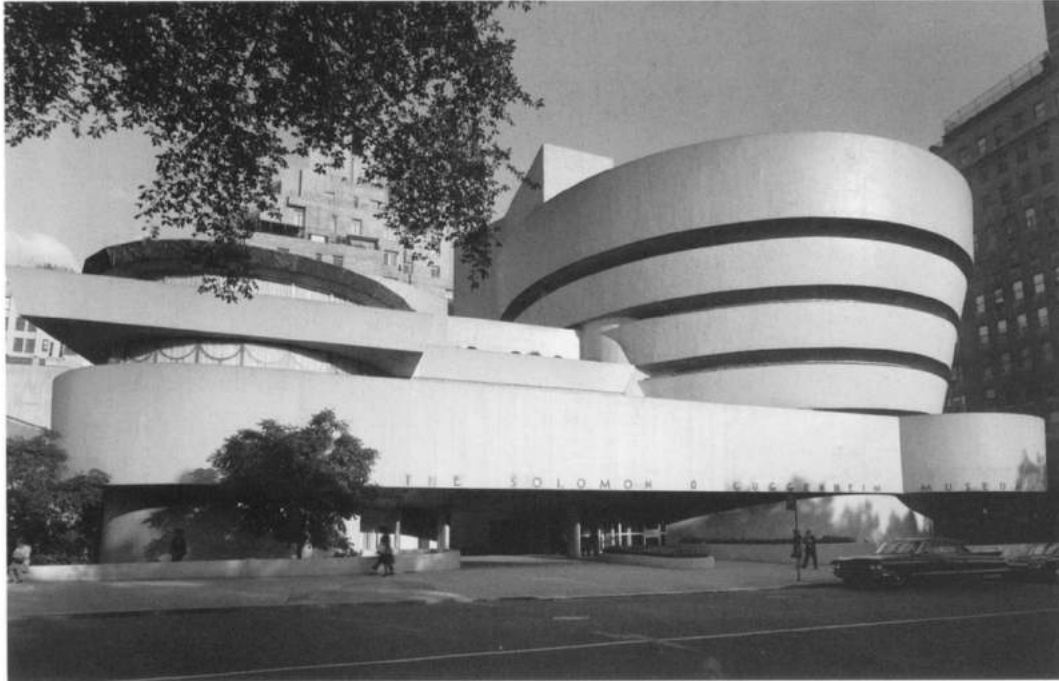

Figure 19. Elevation from Fifth Avenue facing east of Solomon R. Guggenheim Museum, New York City, 1943-59.

Source: Jack Quinan, “Frank Lloyd Wright’s Guggenheim Museum: A Historian’s Report,” *Journal of the Society of Architectural Historians* 52, no. 4 (1993): 466–82, <https://www.jstor.org/stable/990869>. 479

To better understand the case of Solomon R. Guggenheim Museum in New York, it is important to examine the attitude and the role of the client. Guggenheim assigned the task of selecting the architect for the design of the museum to Baroness Hilla von Rebay and she chose Frank Lloyd Wright. Her instruction to Wright was “I want a temple of spirit, a monument!”⁷⁸ In addition to the case of museums becoming the new monumental structures in the cities, the expectation of Rebay epitomizes another aspect of this condition: museums replacing the role of the religious buildings not only in the urban silhouette but also function-wise. As the art critic Jason Farago states, “museums are the new churches”⁷⁹. As its inverted-ziggurat design denotes,

⁷⁸ “About Us,” accessed July 8, 2020, <https://www.guggenheim.org/about-us>.

⁷⁹ Jason Farago, “Why Museums Are the New Churches,” 2015, <http://www.bbc.com/culture/story/20150716-why-museums-are-the-new-churches>.

Solomon R. Guggenheim museum was not just a museum it was a space designed to satisfy the spiritual needs of the visitors.

In addition to its socio-cultural impact, this new culture in architecture has political and economic dimensions. For Solomon Guggenheim, the erection of the Guggenheim Museum in New York was a matter of visibility and prestige. It was more than commissioning the construction of an edifice to harbor the invaluable art collection, it was a political statement. Despite all the negative reactions to the design of the building, Guggenheim supported Wright till his death as he wanted to build a landmark, a monument, an icon in New York City showing his power as a businessman and collector, the power of his collection and the power of art.

Another early example following the trend of erecting spectacular museum buildings that push the limits of architecture and advertise their designers is The Centre Georges Pompidou built between 1971-1977 in Paris. The building housing the Public Information Library, Europe's largest modern art museum and a center for music and acoustic research is considered as an important representative of high-tech architectural style and the first prominent instance of an 'inside-out' building, a building having its structural, mechanical and circulation systems exposed on the exterior.

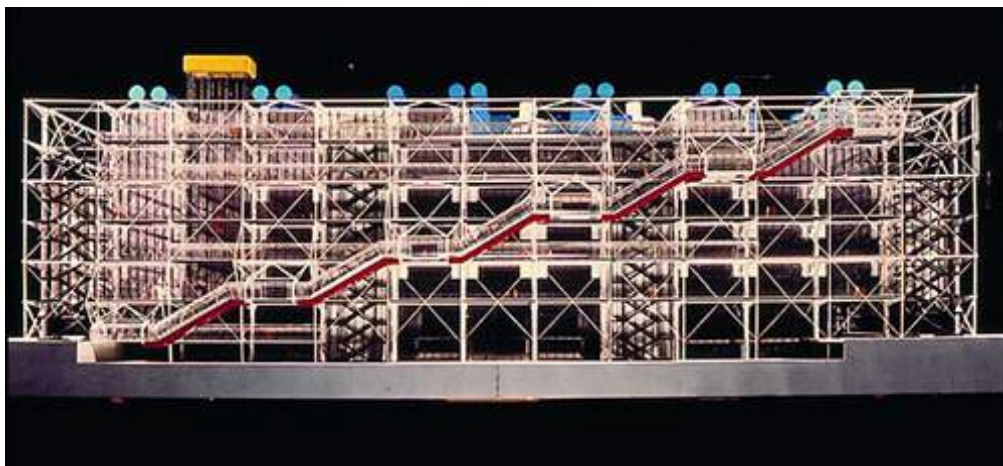

Figure 20. Definitive project model of Centre Pompidou, 1973 by Renzo Piano and Richard Rogers

Source: "The History," accessed October 8, 2020, <https://www.centrepompidou.fr/en/The-Centre-Pompidou/The-history>.

The daring design of The Centre Pompidou “turned the architecture world upside down”⁸⁰ and brought worldwide fame to the architects Richard Rogers, Renzo Piano and Gianfranco Franchini. When Richard Rogers won the Pritzker Prize in 2007, it was mentioned in the jury citation that The Pompidou Centre “revolutionized museums, transforming what had once been elite monuments into popular places of social and cultural exchange, woven into the heart of the city.”⁸¹ In terms of introducing a new style to museum architecture, manifesting the exceptional architectural skills of its architects, honoring its commissioner President Georges Pompidou and being one of the significant monuments of Paris it draws parallels with the Solomon R. Guggenheim Museum in New York.



Figure 21. Centre Pompidou from Sacré Cœur Basilica Montmartre Paris, 2017

Source: Vue Centre Pompidou depuis Basilique Sacré Cœur Montmartre Paris, 11 March 2017, Wikimedia Commons accessed October 8, 2020

https://commons.wikimedia.org/wiki/File:Vue_Centre_Pompidou_depuis_Basilique_Sacr%C3%A9_C%C5%93ur_Montmartre_Paris_2.jpg

⁸⁰ Robin Pogrebin, “British Architect Wins 2007 Pritzker Prize,” *The New York Times*, March 2007, <https://www.nytimes.com/2007/03/28/arts/design/28cnd-pritzker.html?hp>.

⁸¹ “The Pritzker Architecture Prize,” accessed July 8, 2020, <https://www.pritzkerprize.com/jury-citation-richard-rogers>.

With the inauguration of Guggenheim Museum Bilbao on 18 October 1997 an economic dimension was added to the concept of building museums as the monuments/landmarks of the city. The phenomenon “Guggenheim effect” or “Bilbao effect” named after the Guggenheim Museum in Bilbao refers to the economic uplift for cities achieved due to cultural investment and showy architecture.⁸² Despite the modesty of the collection on display, the imaginatively designed museum by the architect Frank Gehry, who is well-known for his iconic architecture, turned around the city of Bilbao which had a negative image as an industrial city in decline distressed by Basque separatist terrorism. The Guggenheim Museum in Bilbao brought global fame both to its architect Frank Gehry and to the dying Basque city.⁸³



Figure 22. Image showing Guggenheim Museum together with the city of Bilbao. Colors edited by the author

Source: Ashley Mendelsohn, “How Analog and Digital Came Together in the 1990s Creation of the Guggenheim Museum Bilbao,” accessed October 8, 2020, <https://www.guggenheim.org/blogs/checklist/how-analog-and-digital-came-together-in-the-1990s-creation-of-the-guggenheim-museum-bilbao>.

⁸² Rowan Moore, “The Bilbao Effect: How Frank Gehry’s Guggenheim Started a Global Craze,” *The Guardian*, October 1, 2017, <https://www.theguardian.com/artanddesign/2017/oct/01/bilbao-effect-frank-gehry-guggenheim-global-craze>.

⁸³ Joseba Zulaika, *Guggenheim Bilbao Museoa Museums, Architecture, and City Renewal* (Reno: Center for Basque Studies University of Nevada, 2003).

Although the case in Bilbao is very striking, it is possible to encounter the “Guggenheim effect” in other cities around the world. Prince Philip Science Museum (2000) in City of Arts and Sciences complex in Valencia designed by Santiago Calatrava and Kunsthaus Graz (2003) designed by Colin Fournier and Peter Cook can be considered as other prominent examples of this effect, showing the transformative power of museum architecture by helping forgotten cities for their revival.

Today, decades after the inauguration of Solomon R. Guggenheim Museum in New York, museum buildings continue to be constructed as the ostentatious monuments of the cities. In some cases they become the new landmarks and attraction points of the already-highly-visited cities of the world, in other cases they generate “Guggenheim effect” and uplift the dying cities.

In addition to the economic, socio-cultural and political impact of these attention-grabbing museums, their influence on the architectural discipline is pivotal. Starting with the Solomon R. Guggenheim Museum the trend of designing museums with bold and progressive architecture created a new culture in the discipline of architecture. This culture refers to the condition of museum architecture being the representative of the most avant-garde ideas and approaches in the architectural discipline. In better terms, the prestige of the architectural profession is manifested through museum buildings. Museums are the mirrors of the latest developments in the field of architecture. As mentioned above, Centre Pompidou is the first prominent example of “inside-out” architecture and it is no coincidence that the building which is the primary example of a new architectural approach is a museum (a cultural center involving a large museum and temporary exhibition spaces). Jason Farago puts the situation into words by saying that: “If churches and cathedrals once stood at the top of the architectural hierarchy, today the museum is the building form that every serious architect dreams of designing.”⁸⁴

⁸⁴ Farago, “Why Museums Are the New Churches.”

As Farago mentions, as a consequence of this new culture, designing a museum building has become a prestigious achievement for the architects. Today, the concepts of “being the architect of a museum” and “being a notable architect” are highly correlated. The clients want their museums to be designed by famous architects and the architects desire to design museum buildings to become famous. Designing a museum has become a matter of reputation in the architectural milieu. Supporting this argument, Forgan says that “[a] new museum building is a prestigious commission, offering architects the opportunity to make their mark on the international scene.”⁸⁵ Jewish Museum (1999) in Berlin designed by Daniel Libeskind, MAXXI Museum (2010) in Rome designed by Zaha Hadid, Musée des Confluences (2014) in Lyon designed by Coop Himmelb(l)au, Louvre Abu Dhabi (2017) and National Museum of Qatar (2019) in Doha by Jean Nouvel are prominent cases embodying this situation.

In most cases, the museum building designed and constructed for prestige happens to be an art museum. It is possible to relate this with the increasing power of art in the society and the growing importance of its role in shaping the society. Among the previously mentioned examples, Solomon R. Guggenheim, Centre Pompidou, Guggenheim Bilbao, MAXXI, Louvre Abu Dhabi are all art museums. It is possible to extend this list with The Rosenthal Center for Contemporary Art (2003) in Cincinnati designed by Zaha Hadid, The Akron Art Museum (2004) by Coop Himmelb(l)au, *Musée national des beaux-arts du Québec* (2016) by OMA and Denver Art Museum (2006) by Daniel Libeskind. Although art museums take the lead in this new culture of museum architecture, there are few examples of natural history and science museums with innovative and attractive designs such as Prince Philip Science Museum or *Musée des Confluences*.

⁸⁵ Forgan, “Building the Museum Knowledge, Conflict, and the Power of Place.”



Figure 23. Musée des Confluences designed by Coop Himmelb(l)au, 2014

Source: “Musée Des Confluences / Coop Himmelb(l)Au,” accessed October 8, 2020, <https://www.archdaily.com/585697/musee-des-confluences-coop-himmelb-l-au>.

Within this context, although there are examples of natural history or science museums that include material related to human anatomy with remarkable architecture there are no anatomy museums, museums entirely devoted to the display of the human body, built with the objectives of this new culture. Despite the rising public and academic interest towards the human body, among the elaborate museum buildings built in the last seventy years, none were anatomy museums. It is an important question why anatomy museum buildings are condemned to be invisible, blended into their surroundings with their ordinary design rather than having an attractive architectural quality.

At this point the Corpus Museum located near Oegstgeest in the Netherlands is worth mentioning. It is an attention-grabbing building composed of a thirty-five meters high transparent structure combined with another structure in the form of the human body created by Reco Productions with the contribution of the Dutch Ministry of Health. Corpus is an interactive space imitating the human body. Briefly, it offers a journey through the body by literally going through a giant human body-shaped building.⁸⁶

⁸⁶ Elena Canadelli, “‘Scientific Peep Show’: The Human Body in Contemporary Science Museums,” *Nuncius* 26, no. 1 (2011): 159–84, <https://doi.org/10.1163/182539111X569801>. 181



Figure 24. Exterior view of Corpus. Voyage through the human body, Oegstgeest.

Source: Elena Canadelli, “Scientific Peep Show’: The Human Body in Contemporary Science Museums,” *Nuncius* 26, no. 1 (2011): 159–84, <https://doi.org/10.1163/182539111X569801>. 182

The visitors go inside from the knee area of the human form and go up towards the brain, visiting every part of the body on the way up. During the tour inside Corpus it is aimed to explain how the human body functions, how organs relate to each other and what to be done to keep it healthy in a “playful” manner with various activities, games, and quizzes. The interactive settings inside Corpus involves 5D effects, sounds and magnified replicas of the organs.

Although it is called as “museum”, it does not accommodate and display a collection of anatomy-related objects with heritage value. ICOM defines museum as follows:

“A museum is a non-profit, permanent institution in the service of society and its development, open to the public, which acquires, conserves, researches, communicates and exhibits the tangible and intangible heritage

of humanity and its environment for the purposes of education, study and enjoyment.”⁸⁷

Considering the definition made by ICOM, it is possible to say that Corpus is not a museum in a literal sense. Instead, it is a “science center” or an “experience” in a more abstract manner. In that sense, it is not convenient to evaluate the architectural quality of Corpus within the context of anatomy museum architecture.

Going further in the topic of anatomy museum buildings, it could be argued that not all, but most of the anatomy museums subsist in buildings that were refunctioned to serve as display spaces. Except few cases such as Museum of Royal College of Surgeons of Edinburgh, Mütter Museum in Philadelphia or Hunterian Museum at the Royal College of Surgeons in London, no anatomy museum was established in a building which was originally designed to accommodate anatomy collections and operate as an anatomy museum. The analysis of the establishment processes of medical museums shows that the main concern of medical collection owners was to “find a permanent space”⁸⁸ instead of designing one.

⁸⁷ “The Extraordinary General Conference Postpones the Vote on a New Museum Definition,” 2019, <https://icom.museum/en/news/the-extraordinary-general-conference-postpones-the-vote-on-a-new-museum-definition/>.

⁸⁸ Henry, “Museums Within a Museum.”



Figure 25. Front view of the Mütter Museum in Philadelphia. Colors edited by the author.

Source: "The College of Physicians of Philadelphia," accessed October 8, 2020, <http://muttermuseum.org/about/the-college-of-physicians-of-philadelphia/>.

Some cases like the Hunterian Museum discussed in Chapter 2.1.1 show that despite the construction of a specific building devoted to the display of the anatomical objects, due to the dramatic growth of the collection, a constant need for additional structures and extensions to the initial building occurred which resulted in the disruption of the original design, maybe caused by the short-sightedness of the architect or the institution.

In addition to the discrepancies between the increasing size the of the collections and the space designed to house them, there are other issues concerning the architecture of the anatomy museums. The buildings which were built to be anatomy museums generally lack specialized design approaches enhancing the unique case of displaying the human body and mindful details regarding the delicacy of creating a space for the intimate and uneasy encounter of the visitors with their own bodies.

In the academic milieu, the studies related to anatomy museums focus on the collection, museum objects, and the spaces where the collections are exhibited are often neglected. As the complex relations between the museum objects and their

display spaces are discovered, the architecture of the museum building and the exhibition design are becoming increasingly prominent. Thus, it becomes quite relevant and crucial to study the spaces of anatomical display and explore the possible design approaches for prospective anatomy museum buildings.

2.2. Medical Gaze and the Shaping of the Spaces of Anatomy

2.2.1. Medical Gaze as a Model of Perception

In his book *The Birth of the Clinic: An Archaeology of Medical Perception* (*Naissance de la Clinique: Une Archéologie du Regard Médical*), Michel Foucault defines a concept called *regard médical* which is translated as “medical gaze” in the book. In order to understand this concept, it is necessary to comprehend the context in which it is introduced. In basic terms, the book is about the development of the medical profession in the Western world. Specifically, it focuses on the emergence of *la clinique*, referring to both clinical medicine and the teaching hospital, during the late eighteenth - early nineteenth century in France. According to Foucault, the mentioned time period has great importance in the history of Western culture. It denotes a *paradigm shift*⁸⁹, a transition from the mindset of the Enlightenment to the mindset of the nineteenth century. Foucault describes this drastic epistemological change as:

“...the relation between the visible and invisible—which is necessary to all concrete knowledge—changed its structure, revealing through gaze and language what had previously been below and beyond their domain.”⁹⁰

Foucault emphasizes the relationship between “seeing and knowing”. He argues that the correlation between what is seen and what is unseen is a critical constituent for the production and perception of knowledge. According to him the new way of

⁸⁹ Referred to the concept introduced in Thomas S. Kuhn, *The Structure of Scientific Revolutions* (Chicago: University of Chicago Press, 1962).

⁹⁰ Foucault, *The Birth of the Clinic: An Archaeology of Medical Perception*. xii

thinking developed by the end of the eighteenth century is associated with the “visibility” of the things. The threshold separating the visible from the invisible transformed and what had remained beneath that threshold began to be exposed, the things that had been invisible till then became visible. The agents leading this significant process are declared as “gaze” and “language”. This thesis does not address the concepts related to language so the focus will be on “gaze”. Regarding the role and the importance of “seeing” in this *paradigm shift*, Foucault says:

“The eye becomes the depository and source of clarity; it has the power to bring a truth to light that it receives only to the extent that it has brought it to light; as it opens, the eye first opens the truth: a flexion that marks the transition from the world of classical clarity—from the ‘enlightenment’—to the nineteenth century.”⁹¹

For Foucault, the reason for the epistemological break happened by the end of eighteenth century was the understanding of the direct relationship between “seeing” and “truth”. The power of “seeing” as a revealer of the truth was understood which led to a significant change in the way of perceiving the world. He uses the phrase “the eye” as a metonymy for the act the of “seeing” since it is the organ which is responsible for sight.

The realization of the strong bonds between “knowledge”, “visibility”, “seeing” and ‘truth’ caused a sudden reorganization of knowledge which naturally affected the medical sciences. While exploring this critical change in medical understanding, Foucault frequently builds his arguments upon the concept of “gaze” and refers to the act of seeing. He relates the transformation of medical perception and practice with the activity of the “gaze” whose powers began to be recognized by the end of eighteenth century. Throughout the book, he uses the phrases “empirical gaze”, “medical gaze”, “clinical gaze”, “anatomical gaze”, “surface gaze”, “doctor’s gaze” while discussing the establishment of clinical medicine. Although he uses different words to denote different aspects of this “gaze” in different contexts, in general, he refers to medical perception/medical way of seeing. Considering the translator’s

⁹¹ Foucault. xiii

note, it is possible to use “medical gaze” as an umbrella term to cover all these phrases used by Foucault.

In different chapters, distinct characteristics of ‘medical gaze’ are put forward. Among the virtues attributed to the “medical gaze”, its spatial quality draws attention. The importance attributed by Foucault to the concept of “space” and its relationship with “seeing and knowing” is highly crucial. The very first sentence of the book reveals the perception of Foucault on the subject:

“This book is about space, about language, and about death; it is about the act of seeing, the gaze.”⁹²

While describing the activity of medical gaze Foucault uses spatial metaphor. He refers to concepts related to space such as dimensionality, depth and surface to explain the interaction of medical gaze with the patient.

“The medical gaze must therefore travel along a path that had not so far been opened to it: vertically from the symptomatic surface to the tissual surface; in depth, plunging from the manifest to the hidden; and in both directions, as it must continuously travel if one wishes to define, from one end to the other, the network of essential necessities. The medical gaze, which, as we have seen, was directed upon the two-dimensional areas of tissues and symptoms, must, in order to reconcile them, itself move along a third dimension. In this way, anatomico-clinical range will be defined.”⁹³

According to Foucault, medical gaze should be capable of perceiving what is beyond the visible surface. Its activity should not be superficial or limited to two-dimensions. Rather than moving horizontally, it should proceed vertically. It should move in depth traversing the surfaces and linking them in three-dimensions. It is possible to infer that the medical gaze Foucault mentions has a spatial quality. In other words, it refers to a visual system that is about perceiving an object in three-dimensions, understanding the depth and relating the surfaces along that depth. Foucault also claims that medical gaze “plunges into the space that it has given itself the task of

⁹² Foucault. ix

⁹³ Foucault. 135

traversing.”⁹⁴ The actions “plunging into” and “traversing” are important since they are also used by Giuliana Bruno in a similar context. Instead of medical gaze she prefers the term anatomical or anatomical-analytical gaze and argues that this gaze “dissects by moving across and in depth, plunging into space and traversing it.”⁹⁵ It means that medical gaze have two important abilities: going beyond the outer surface of an entity and passing through all along its depth.

Furthermore, on the spatial quality of the medical gaze Foucault asserts that “[t]he anatomico-clinician’s gaze has to map a volume; it deals with the complexity of spatial data which for the first time in medicine are three-dimensional.”⁹⁶ The sentence implies that, in addition to penetrating a volume and traversing it, medical gaze should map that volume in three-dimensions by using the space-based information related to it. This shows that medical gaze is interested in perceiving a three-dimensional entity with its entire volume including its interior space. It is not only about “seeing” but also understanding the intricate details of the entity. It is a profound spatial reading beyond the covering surface. Therefore, the medical gaze suggests a reconciliation of inner space with the outer surface and the inner space in itself through mapping.

Since the medical gaze operates on the patient, the volume or the space referred by Foucault can be interpreted as the body of the patient or with more general terms, the human body. Consequently, what is plunged, traversed and mapped becomes the human body. In this context, human body is described as a spatial and mappable entity which is an uncommon way of perceiving the body.

Although ‘the eye’ is used as a metonymy for ‘seeing’, the exercise of the medical gaze involves both the eye and the mind. Especially the concept of mapping requires the active participation and collaboration of the eye and the mind. The three-

⁹⁴ Foucault. 136

⁹⁵ Giuliana Bruno, *Public Intimacy: Architecture and the Visual Arts* (Cambridge: The MIT Press, 2007). 93

⁹⁶ Foucault, *The Birth of the Clinic: An Archaeology of Medical Perception*. 163

dimensional mapping of the body occurs in mind through the combination of the visual data gathered by the eye.

The idea of spatially mapping the body in mind is referred to as “anatomical visualization”⁹⁷ by Hallam. She describes anatomical visualization as “a process that creates a three-dimensional image of the human body in the mind through extended periods of close visual investigation”⁹⁸.

In medical schools, students are expected to develop certain anatomical skills. Among these skills, the ability to do anatomical visualization is extremely essential to be able to comprehend the complex organization of the human body. The students acquire this skill in medical school and effectively use it during their learning process and practice.

Considering its highly complex organization, the human body is studied in pieces. Both the medical education and medical practice are shaped around this condition. In medical schools, the human anatomy is taught piece by piece. Every part of the body is treated individually in detail. While learning the body piece by piece, the students need to combine all these pieces in mind to have a complete understanding of the human body. On this subject, Hallam says that:

“Although students learned anatomy in ‘pieces’, these had to be fitted together so that the relations between them could be visualized and the body understood, in terms of structure and function, as a ‘single unit’.”⁹⁹

As the body is studied in numerous pieces, also each piece is communicated through numerous media. During their education, students utilize two dimensional illustrations and diagrams, three-dimensional models from wax, clay, wood or plastic, photographs and videos in addition to the prosected cadavers. They are

⁹⁷ Elizabeth Hallam, *Anatomy Museum: Death and the Body Displayed* (London: Reaktion Books, 2016). 49

⁹⁸ Hallam.50

⁹⁹ Hallam.50

expected to reflect their knowledge attained through these materials on actual human bodies.

Learning, moreover internalizing the human anatomy as a medical student requires oscillating between 2D and 3D and jumping from one medium to the other. The transition from 2D to 3D and vice versa and the multiplicity of the instruments both enhance and complicate the anatomical education. As an important part of their education, students are expected to develop the skill of “anatomical visualization” by using the above-mentioned materials. By means of physical objects such as illustrations, diagrams, models, photographs, videos and specimens, a virtual image is generated in mind. In other words, students visually, yet virtually map the representations of the body in order to be able to create a three-dimensional mental image of it.

“Relationships between parts of a single model, between several models, and between models and other anatomical materials were discerned by students engaged in an intermedial process of feeling shapes, seeing colours, interpreting lines and reading labels. Here anatomical intermediality aided the visualization of an integrated anatomical body.”¹⁰⁰

Like a collage, the pieces of the body rendered through various media come together and constitute a complete body in mind. The multiplicity of the media involved in the process generates an image that is so abstract that it corresponds to all bodies but none of them in particular at the same time.

Anatomical visualization is about relating fragments, making connections and detecting associations in a spatial context. The human body divided into pieces for study is mentally recreated through the process of anatomical visualization. During that process the pieces in 2D and 3D are linked together in a 3D space. Translating planar images, schemes and illustrations to the third dimension is a compelling task. Therefore, in addition to the complexity stemming from the intermediality, the

¹⁰⁰ Hallam.92

necessity to switch between different dimensions complicates anatomical visualization.

Since the human body has a specific form and structure, the pieces come together with a certain “order”. The body parts have specific locations with reference to each other and this complex structure has to be virtually rebuilt in the mind of a student. Despite its difficulty the continuous shuttle between 3D and 2D anatomical renderings enhances the comprehension of the associations between anatomical structures. This aids students to develop a “3D mental map of the body”¹⁰¹.

Medical practitioners are expected to use this advanced skill of “anatomical visualization” not only during their education but also in medical practice. For the accurate diagnosis of a disease, the findings of the physical examination together with the visual and numerical data collected from medical devices must be combined and associated with the three-dimensional mental image of the body. The data showing the individual case of the patient is mapped onto the generic body image developed throughout the medical education.

While explaining anatomical visualization “mind’s eye” is a concept that is worth mentioning. It means the “mental faculty of conceiving imaginary or recollected scenes”¹⁰² which refers to the ability of the mind to create a mental picture using the conceived data.

“...they built up a “3D structural image of the whole body’ in their ‘mind’s eye’. This body comprised anatomical parts and their relations abstracted from anatomical materials which were (predominantly but not completely) depersonalized and dehistoricized.”¹⁰³

The representational body created in mind’s eye is an “abstract body”. It does not have any personal data. It is ageless, nationless, raceless, without character traits or

¹⁰¹Debra Patten, “What Lies Beneath: The Use of Three-Dimensional Projection in Living Anatomy Teaching,” *The Clinical Teacher* 4, no. 1 (2007): 10–14, <https://doi.org/10.1111/j.1743-498X.2007.00136.x>. quoted in Hallam, *Anatomy Museum: Death and the Body Displayed*.91

¹⁰² “Mind’s Eye,” in *Merriam-Webster Dictionary*, accessed July 8, 2020, [https://www.merriam-webster.com/dictionary/mind%27s eye](https://www.merriam-webster.com/dictionary/mind%27s%20eye).

¹⁰³ Hallam, *Anatomy Museum: Death and the Body Displayed*.94

life experience. It corresponds to all bodies but it is not any of them in specific. During medical education and practice the mental body and the concrete body serve as models for each other that is a “cross-fading of experience and representation”¹⁰⁴ Real life experience of a cadaver or a patient’s body and the representational body in mind are in constant interaction for a complete and seamless learning, training, diagnosis or treatment.

In addition, it is important to underline the fact the three-dimensional image of the body with its intricate interiors in the student’s mind’s eye is not static or finished, instead it is conceived as a dynamic image, updated, enhanced and developed during training with further material providing further knowledge.¹⁰⁵

The notion of “mind’s eye” is also related to “mental imagery” which is a quasi-perceptual experience availing the generation and conservation of an image in mind, that has been vastly utilized in mnemonics for centuries.¹⁰⁶ More importantly it is believed to be highly involved in “visuo-spatial reasoning and inventive or creative thinking”¹⁰⁷ which are both very essential for medical education and practice.

“The medical gaze is now endowed with a plurisensorial structure. A gaze that touches, hears, and, moreover, not by essence or necessity, sees.”¹⁰⁸

Foucault argues that “medical gaze” is not simply about seeing. Hearing and touch are added to the sight. The perceptual experience of the eye is enhanced with the data collected by the ear and the skin. This multisensorial gaze integrates the visual, tactile and audial information and maps the body accordingly. Although other senses have a significant contribution to the medical perception, Foucault still underlines the sovereignty of the vision.

¹⁰⁴ Hallam.52

¹⁰⁵ Hallam.52

¹⁰⁶ The relationship between mental imagery and mnemonic arts is further explained in Chapter 3.1.2

¹⁰⁷ Nigel J.T. Thomas, “Mental Imagery,” accessed July 8, 2020, <https://plato.stanford.edu/entries/mental-imagery/>.

¹⁰⁸ Foucault, *The Birth of the Clinic: An Archaeology of Medical Perception*.164

In fact, the active use of multiple senses together constitutes the essence of medical practice. Having been mentioned and emphasized by many physicians for centuries, especially, sight and touch play significant roles in medical practice for the right diagnosis and effective treatment. Thus, the disciplining of the eye and the hand becomes extremely crucial in the education of medical students. Specifically, Scottish surgeon, anatomist, neurologist, artist, and philosophical theologian who is known with his ground-breaking studies on human nervous system and influential ideas on anatomical teaching, Charles Bell (1774-1842) strongly defended training hand and eye together. Berkowitz describes the approach of Bell as follows:

“...doing was seeing in anatomy. Anatomical objects provided vision to the hands that held and described, and eventually replicated, those objects. While the hand was taught, it was taught to see, rather than to feel, in order to know...Bell taught advanced students by having them dissect out and preserve their own specimens, in effect having them conduct their own research... Students learned to see by creating and preserving anatomical objects and by drawing, using their hands.”¹⁰⁹

During the late eighteenth-early nineteenth century students were expected to carry out dissections and prepare their own specimens for later use. Also, they were making the drawings of the dissected and dismembered bodies. While carrying out these activities, they highly relied on their senses of sight and touch. This shows that the hand and eye were seen as analogous organs, therefore their training was interrelated and simultaneous.¹¹⁰ Despite the drastic alterations in medical education, the importance of touch and sight and the together training of hand and eye is still highly promoted. On this subject, Hallam wrote:

“...students continued to examine cadaveric material, visually and manually, to develop their three-dimensional spatial knowledge of anatomy.”¹¹¹

¹⁰⁹ Berkowitz, “Systems of Display: The Making of Anatomical Knowledge in Enlightenment Britain.” 373

¹¹⁰ Berkowitz. 373

¹¹¹ Hallam, *Anatomy Museum: Death and the Body Displayed*.79

Anatomical visualization is strongly related to the multisensory practice of the medical gaze. The sensory data obtained through the hand and the eye are processed in mind to have a holistic idea about the body under scrutiny. The spatial mapping of the body in mind mainly occurs by means of the visual and tactile experience.

“Thus armed, the medical gaze embraces more than is said by the word ‘gaze’ alone. It contains within a single structure different sensorial fields. The sight/touch/hearing trinity defines a perceptual configuration in which the inaccessible illness is tracked down by markers, gauged in depth, drawn to the surface, and projected virtually on the dispersed organs of the corpse.”¹¹²

Foucault underlines another significant characteristic of the medical gaze. Regarding its multisensorial nature, it has the ability to attain corporeal knowledge that is hidden in the symptoms, buried in the viscera, marked on the surface and reflected on different pieces of the body. In clear terms, Foucault argues that the information related to the illness which is “invisible” at the first sight is obtained through medical gaze which sees, touches and hears the signals embedded and manifested by the body. Since the gaze operates spatially, sensing the surfaces and depths of the body to bring the obscured knowledge of the disease to light, its activity in this context is described as “spatial assignation of the invisible”¹¹³ by Foucault. In parallel with this concept, as a part of anatomical visualization, medical students and practitioners are expected to imagine what is beneath the visible surface, in other words to visualize the invisible through the knowledge and skills attained by the medical gaze. Regarding that, Hallam wrote:

“Gaining sufficiently skilled, in-depth knowledge of the body would enable the medical practitioner to see the body, as Cooke asserted using the ‘metaphor of the day’, as though it were ‘like glass, transparent’. From this perspective, thorough knowledge manifested as the ability to see through the body to visually reach into its deep anatomical structures... Body envisaged

¹¹² Foucault, *The Birth of the Clinic: An Archaeology of Medical Perception*, 164.

¹¹³ Foucault, 164.

as glass, a transparent material, allows those knowledgeable and skilled in anatomy to ‘see’ into its interior, into its very depths with striking clarity.”¹¹⁴

The actions “plunging into” and “traversing” used for describing the way medical gaze behaves are related to this condition. In order to be able to accomplish anatomical visualization, the students have to overcome the opaque surface covering the body which is the skin, and then proceed through the opaque organic masses beneath the skin which are the organs. This is only possible with the good training of not only vision but all the other senses.

Briefly, the medical gaze with its plurisensorial nature and by functioning spatially, renders the body transparent, in clear terms it makes the “invisible”, “visible”.¹¹⁵

2.2.2. Activities and Spaces Under the Influence of the Medical Gaze

Although Foucault uses the concept “medical gaze” within the context of late 18th - early 19th century as he claims that the powers of the medical gaze began to be discovered during that time period but in fact as a perception model it has a long history. Considering the characteristics and the activity of the medical gaze defined by Foucault, its influence in medical education and medical practice could be observed even centuries before. Within this context, it is possible to assert that the profession of medicine, which has origins dating back to ancient times, has been developed and shaped under the influence of the medical gaze for centuries. As a consequence of this, the spaces that have been built for medical activities have always been designed and developed under the medical gaze. For instance, the anatomical theatre buildings, which first appeared in the 16th century, are considered

¹¹⁴ Thomas Cooke, “The Teaching of Anatomy: Its Aims and Methods,” *The Lancet* 142, no. 3662 (1893): 1153–55, [https://doi.org/10.1016/S0140-6736\(01\)45576-0](https://doi.org/10.1016/S0140-6736(01)45576-0). quoted in Hallam, *Anatomy Museum: Death and the Body Displayed*. 283

¹¹⁵ Foucault, *The Birth of the Clinic: An Archaeology of Medical Perception*. xiii

to be the signature spaces of anatomical scholarship and they perfectly embody the powers of the medical gaze.¹¹⁶

In *The Birth of the Clinic*, Foucault talks about the structure of medical profession. He talks about two different domains in medicine: “the hospital domain” and “the pedagogic domain”¹¹⁷. Hospital domain refers to the medical practice and the pedagogic domain refers to the medical education. Under the influence of the medical gaze, these two domains have grown in a highly integrated manner. As a result, in medicine, there have been no clear distinction between education and practice unlike other disciplines. As a vital component of medical education, the students have been obliged to acquire “anatomical skills” via “practical experience” which means that the development of the visual and tactile abilities have been ensured through practical exercises. While learning, the students have been expected to practice on corpses or real patients. “Learning-by-doing” have always been the key approach in medical education. Reciprocally, many medical practitioners have involved in medical education by teaching and guiding the medical students.

This interwoven condition of the medical practice and medical education have caused medical activities to become multifold, fluid and interrelated. The interwovenness and the variety of the medical activities, originally caused by the medical gaze, made way for the interrelatedness and diversity of the medical spaces. This condition is most observable in the case of medical school campuses.

Apart from its advanced faculties, the relation between “seeing and knowing” constitutes the essence of the medical gaze. Hence, among the multifarious spaces in medical school campuses, anatomy museum shines out. Anatomy museum is a space devoted to the visual perception of the anatomical body in display. It serves for the acquisition of the anatomical knowledge through optical practices: glancing, gazing, observing, and focusing. Towards the end of the 18th century anatomy museums

¹¹⁶ The history and prominent qualities of anatomical theatres are elaborated in Chapter 3.

¹¹⁷ Foucault, *The Birth of the Clinic: An Archaeology of Medical Perception*. 109

became an essential component of the medical schools, as visualization and display have become highly significant for anatomy education.

Medical historian Jonathan Reinarz argues that the museum was to nineteenth-century medical education what the clinic was to its practice.¹¹⁸ In addition, in 1836, the anatomist Frederick Knox wrote that “[w]ithout museums the profession [of anatomy] would be in the state of man without a language”.¹¹⁹ Especially, during the 19th and early 20th centuries, students expected a medical school to include an anatomy museum as it became very common for colleges and teaching hospitals to own collections of anatomical material for pedagogical use.¹²⁰ Then, anatomy museums lost their former influence in medical training due to the changes in the education methods and the invention of new visualization techniques and mostly became museums of medical history. Nevertheless, they are still valued and engaged in medical education by different means in prominent medical schools. For instance, in the University of Florence, visits to the Pathology Museum guided by the lecturers are currently a standard component of the course of Pathological Anatomy at the Faculty of Medicine.¹²¹

Within this context, the spaces within the medical school campuses and their interwoven organization, claimed to be developed under the influence of the medical gaze, is examined, centering on the anatomy museum space. The case selected for this analysis is the Anatomy Museum and the spaces around it in the Anatomical

¹¹⁸ Jonathan Reinarz, “The Age of Museum Medicine: The Rise and Fall of the Medical Museum at Birmingham’s School of Medicine,” *Social History of Medicine* 18, no. 3 (2005): 419–37, <https://doi.org/10.1093/shm/hki050>. quoted in A.W. Bates, “‘Indecent and Demoralising Representations’: Public Anatomy Museums in Mid-Victorian England,” *Medical History* 52, no. 1 (2008): 1–22, <https://doi.org/10.1017/s0025727300002039>. 1

¹¹⁹ Frederick John Knox, *The Anatomist’s Instructor, and Museum Companion: Being Practical Directions for the Formation and Subsequent Management of Anatomical Museums* (Edinburgh: Adam and Charles Black, 1836). quoted in Bates, “‘Indecent and Demoralising Representations’: Public Anatomy Museums in Mid-Victorian England.” 1

¹²⁰ Bates, “‘Indecent and Demoralising Representations’: Public Anatomy Museums in Mid-Victorian England.” 7

¹²¹ Gabriella Nesi, Raffaella Santi, and Gian Luigi Taddei, “Art and the Teaching of Pathological Anatomy at the University of Florence since the Nineteenth Century,” *Virchows Archiv* 455, no. 1 (2009): 15–19, <https://doi.org/10.1007/s00428-009-0794-y>.16

Department of Marischal College in the University of Aberdeen located in the northeast Scotland.

Marischal College was founded in 1593 and merged with King's College in 1860 to form the modern University of Aberdeen. The school of medicine was situated in the Marischal College. The construction of the current Marischal College building began in 1830s and a second phase was completed in 1906.

In the early 1800s, there were many collections including human remains in Aberdeen. The body fragments, specimens and bones were circulated among curious collectors, doctors, anatomists, surgeons and scholars and displayed in manifold settings varying from houses to universities. In the late 1850s, some of these collections began to be gathered in the Anatomical Department of Marischal College. Although the exact date of the opening of the Anatomical Museum is unclear, it is known that c.1860-90, it was built and developed as a space devoted to the collecting, display and study of human and comparative anatomy.¹²² There is documentation describing the opening of the renovated Anatomy Museum at Marischal College in 1881 as part of the general restoration of the Anatomy department at that time.¹²³ After going through many changes, in 2009 the Anatomy Museum's collection was transferred from its "Victorian shell" to its most recent location and reconfigured in the new medical school building at Aberdeen's hospital complex.¹²⁴ Within the scope of this study, the original architectural layout of the Anatomy Museum and its surrounding spaces is analyzed, before the relocation of the collection in 2009.

¹²² Hallam, *Anatomy Museum: Death and the Body Displayed*. 133

¹²³ "Marischal College," accessed July 8, 2020, <https://www.abdn.ac.uk/about/campus/marischal-college-394.php>.

¹²⁴ Hallam, *Anatomy Museum: Death and the Body Displayed*. 351



Figure 26. View of Marischal College Aberdeen, looking towards the sea in the distance, c.1906

Source: Elizabeth Hallam, *Anatomy Museum: Death and the Body Displayed* (London: Reaktion Books, 2016). 206

Anatomy Department in Marischal College, like the ones in other universities, presents a pedagogical system of interrelated activities, spaces and objects. Especially the relationship between the spaces and the activities is quite important. A “nexus of activities”¹²⁵ which includes observing, examining, dissecting, dismembering, associating, preserving, handling, writing, reading, listening, drawing, modelling, demonstrating, displaying, lecturing occur in the anatomy department. The spaces inside the Anatomy Department have been developed in relation with these activities constituting the basis of the anatomy education. Essentially, the science laboratory is associated with the activities of observing and examining; the workshop with preserving, handling, drawing and modelling; lecture theatre with demonstrating, lecturing and listening; library with reading and writing; mortuary and museum store with preserving; dissecting room with dissecting,

¹²⁵ Michael Lynch, “The Production of Scientific Images: Vision and Re-Vision in the History, Philosophy and Sociology of Science,” in *Visual Cultures of Science: Rethinking Representational Practices in Knowledge Building and Science Communication*, ed. Luc Pauwels (Hannover: Dartmouth College Press, 2006), 26–40.27 quoted in Hallam, *Anatomy Museum: Death and the Body Displayed*.50

dismembering and observing and anatomy museum with displaying and observing. Although this easy and quick match-up explains the basic associations between the spaces and the activities, the real situation in the Anatomy Department is much more complicated than this. To better understand the complex organization of the spaces and activities and the special position of the Anatomy Museum in the Anatomy Department, each space in the architectural program is analyzed both on an individual basis and in relation with the museum space.

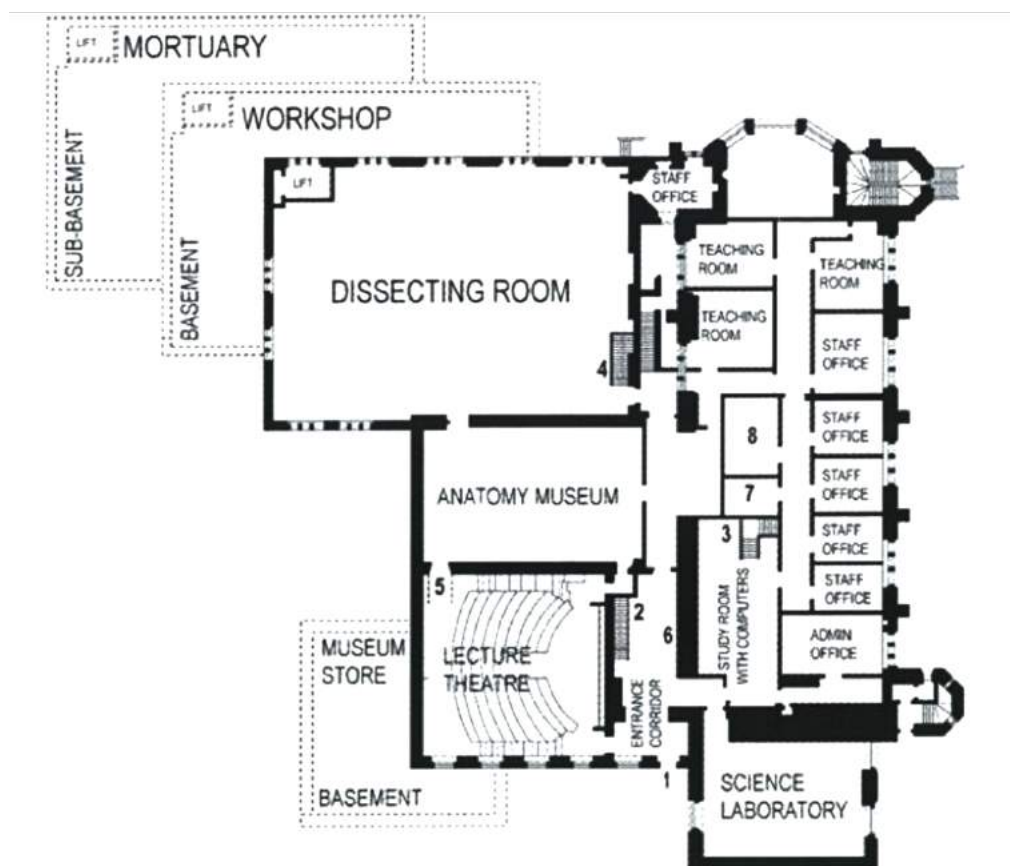

Figure 27. Floor plan, Anatomy Department, Marischal College, University of Aberdeen, as 2009.

Source: Elizabeth Hallam, *Anatomy Museum: Death and the Body Displayed* (London: Reaktion Books, 2016), 50

Mortuary

The mortuary was located in the Anatomy Department's sub-basement, two floors below the dissecting room (Fig. 27). An elevator was connecting these two spaces

to each other. In this space, the bodies which were donated to the faculty for dissection were stored and preserved. In this space the focus was on the preservation of the whole bodies that are not yet “anatomized”. To prevent their decay, the bodies were embalmed which was a process including three main steps. First, the body was disinfected, then the body fluids including blood were drained and finally an embalming fluid including formaldehyde was pumped through the blood vessels. This made them persistent enough to survive through the extensive process of visual and tactile examination that included many interventions and manipulations in different levels in the dissecting room. The embalmed bodies were kept in individual storage compartments until needed.¹²⁶



Figure 28. Mortuary in the Anatomy Department, Marischal College, University of Aberdeen, mid 20th century
Source: Elizabeth Hallam, *Anatomy Museum: Death and the Body Displayed* (London: Reaktion Books, 2016), 56

¹²⁶ Hallam, *Anatomy Museum: Death and the Body Displayed*. 57

Upon delivery, the personal information related to the bodies, such as the name and the wished regarding burial or cremation, were registered and kept away. Also, all the clothing and jewelry was removed, hair was shaved off. Then a unique number was assigned to the body. During the examination and study in the department, the name of the donor was never mentioned, only the given number was used. When the anatomical process was over, the body was transferred out of the department to be buried or cremated, the number was removed and the name was reattached.¹²⁷

Embalming for anatomical purposes converted the deceased body to a depersonalized body for scientific study. From that moment on, the body was not a “subject” anymore, it was an “object”, a “human material”. By means of embalming the body transformed to visual and tactile learning resource for the students.

Workshop

Workshop was in the basement, one floor above the mortuary, right below the dissecting room and again connected to it by an elevator (Fig. 27). In the workshop anatomical specimens preserved in fluid-filled transparent cases were restored, models were built and maintained for display in the Anatomical Museum. For modelmaking purposes, workshop space included facilities mainly for wood, metal and acrylic work. Different from the mortuary, in workshop space the body began to be “anatomized” in terms of focusing on anatomical parts in soft tissue or skeletal form, or their models.¹²⁸

¹²⁷ Hallam. 58

¹²⁸ Hallam. 60

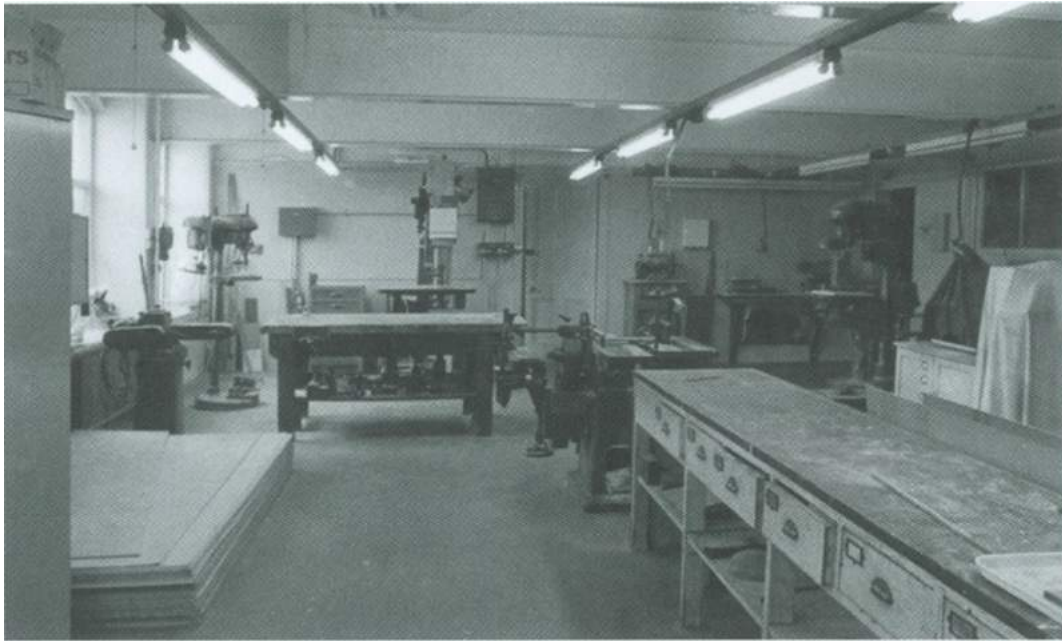

Figure 29. Workshop in the Anatomy Department, Marischal College, University of Aberdeen, mid 20th century

Source: Elizabeth Hallam, *Anatomy Museum: Death and the Body Displayed* (London: Reaktion Books, 2016), 59

In addition, the workshop was a maintenance space for the specimens in the Anatomy Museum. The ageing, dissolving or falling away specimens or the damaged display cases were all repaired and restored in the workshop. The anatomical displays in the museum were sustained and renewed by means of the practices in the workshop, therefore the workshop was quite significant for the museum. The continuity and the quality of the display in the museum was highly dependent on the continuity and the quality of the activities in the workshop. Nevertheless, the investment of the university in this area declined after the 1980s. As a consequence, the activity of the workshop declined and the machinery, tools and equipment became deactivated historical objects.¹²⁹

¹²⁹ Hallam. 60

Museum store

The store was located in the residual space generated by the ascending tiers of seats of the lecture theatre (Fig. 30). It was only accessible by the staff and like the mortuary and workshop was entered through a concealed door in the Anatomy Museum. The discarded objects due to their reduced relevance, and those that were worn out, unstable or damaged, were accumulated in the museum store by the late 1990s.¹³⁰ At first sight, the store may seem like a secondary or insignificant space but in fact, it was an extremely valuable space. Hallam wrote on the subject as follows:

“...the store was not static,...from an anthropological perspective it was a shifting palimpsest where material accumulations could reveal historical aspects of anatomy, past collecting practices and traces of dismantled displays that were no longer visible in the current museum.”¹³¹

Regarding that, it is possible say that the role of the museum store was beyond being just a depot space. It worked like an archive of the Anatomy museum recording the history of the museum display. In a way, it was a “museum of the museum”, preserving not only the obsolescent objects themselves but also keeping their chronicle.

¹³⁰ Hallam. 60

¹³¹ Hallam. 60



Figure 30. Museum store in the Anatomy Department, Marischal College, University of Aberdeen, 2007

Source: Elizabeth Hallam, *Anatomy Museum: Death and the Body Displayed* (London: Reaktion Books, 2016), 61

In the museum store the objects were not simply stacked up on top of each other. There was a certain order organizing the space. The spatial arrangement of the store space, established in 2003, consisted of three main categories of material which were human skeletal remains, anatomical models and unused scientific instruments. Each category occupied a certain space and subdivided by temporal and morphological distinctions. Also, the historical material was distinguished from that in regular use.¹³²

¹³² Hallam. 64

Lecture theatre

After entering the building, the main corridor led to the lecture theatre. The theatre included ascending tiers of semicircular seats, providing a seating capacity of 250, and a stage for the instructor. The lecture theatre and the Anatomy Museum were highly related. In most of the lectures, the anatomy professors demonstrated anatomical material such as plastic models, skeletons or specimens brought from the Anatomy Museum to visually reinforce the subject that was covered. The tables located at the stage area functioned as display platforms for the museum objects. In addition, the lecture was enhanced with the use of lantern. Through the lantern slides, the photographs of the specimens in Anatomy Museum were shown in the lecture theatre. The technology of lantern enabled the visual amplification of the images, while projecting for large audiences of students. The museum objects physically brought or projected in the lecture theatre complemented the verbal information given by the professor, hence enriched the learning process.¹³³

¹³³ Hallam. 217

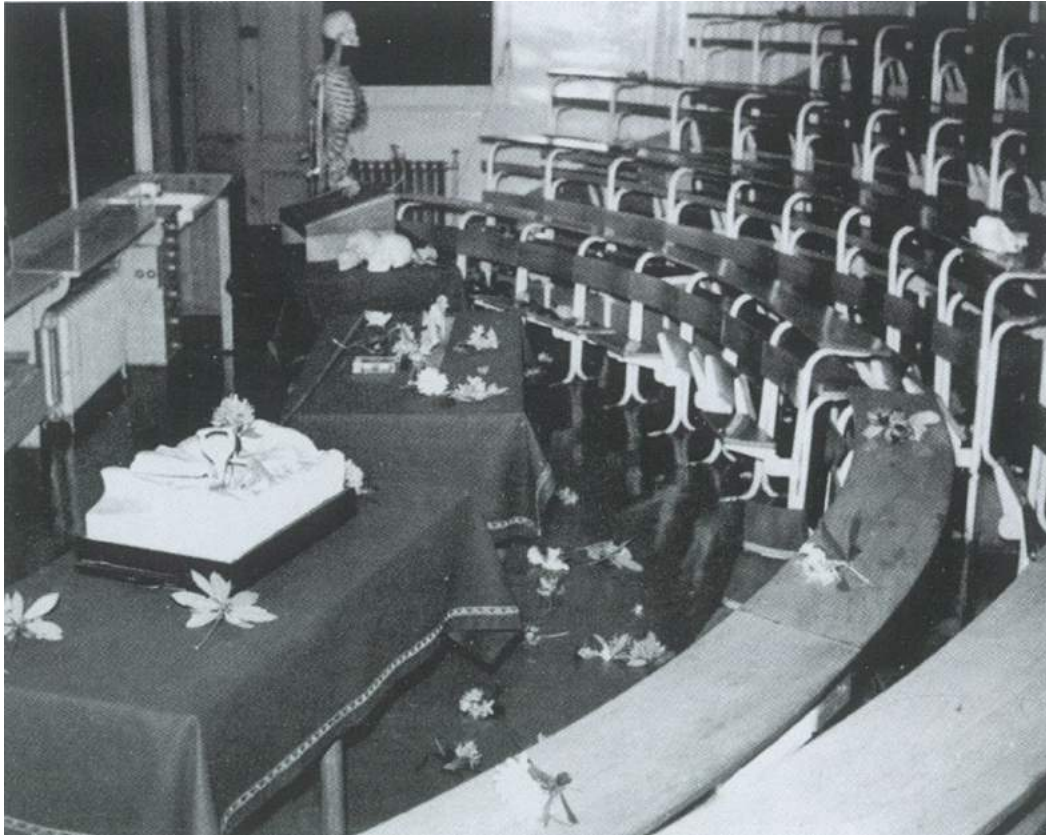

Figure 31. Lecture theatre with an ear model on the table in the Anatomy Department, Marischal College, University of Aberdeen, 1964

Source: Elizabeth Hallam, *Anatomy Museum: Death and the Body Displayed* (London: Reaktion Books, 2016), 217

Science Laboratory

In the department there were three main spaces allocated for practical learning which were all located near the lecture theatre. These spaces were the dissecting room, Anatomy Museum and the science laboratory and in all three spaces “human material” was examined through visual and tactile contact. As the students learned and practiced upon the embalmed bodies in the dissecting room and the specimens in the Anatomy museum, in the science laboratory they were working mainly on the osteological material. The laboratory was filled with rows of wooden study tables and chairs. For the lectures, osteological specimens were brought from the museum to provide guidance to the students during the lab sessions. There were anatomical

objects displayed in the laboratory in a glass cabinet. In addition, illustrations that were mounted in frames and arranged like the pages of a book were hinged on the wall.¹³⁴



Figure 32. Science laboratory with osteological specimens on study tables in Anatomy Department, Marischal College, University of Aberdeen, c.1960

Source: Elizabeth Hallam, *Anatomy Museum: Death and the Body Displayed* (London: Reaktion Books, 2016), 263

Dissecting room

The dissecting room was located on the ground floor and had the largest teaching area. (Fig. 27) It had a nineteenth century glass roof and large frosted-glass windows to maximize the daylight intake while ensuring privacy. Walls glazed with off-white tiles and a row of sinks running the length of the room were the indications of the

¹³⁴ Hallam. 263

emphasis put on hygiene. The room was equipped with rows of numerous stainless-steel dissecting tables that were brightly illuminated from above. The pungent smell of the formaldehyde used in the embalming fluid was a distinctive feature of the dissecting room.¹³⁵ In addition to the uncomfortable odor, dissection rooms are known to be sentimentally challenging spaces as the confrontation with the dead bodies might trigger complex emotions or wake painful memories.

Considering the activities that took place in the dissecting room, in addition to being a space for the dissection of the dead bodies, it was also a display space. In general, the concept of display is associated with the museum space yet, it occurred in the dissecting room in multiple ways, as well.

Temporary displays were set up in the dissecting room. For certain time periods certain parts of the body were studied and models related to that part were brought from the museum store and disposed on the tables. For instance, during the weeks devoted to the dissection of the upper limb, models showing the structure of the arm and the hand were exhibited in the dissecting room for enhancing the learning process of the students.¹³⁶ Another mode of display was the students themselves. They were suggested to observe their own bodies through full-length mirrors provided in the dissecting room. In addition, it is possible to think that the viscera if the cadaver revealed during the dissection process suggests another display. In better terms, the act of dissecting could be considered as a display by itself. These examples show that, through the act of display, the Anatomy Museum and the dissecting room were conceptually connected. In line with this idea, Hallam wrote:

“At Marishcal College disciplined interaction with tactile displays in the dissecting room informed students’ engagements with displays in the adjoining Anatomy Museum- and,...patterns of anatomical study in the museum also in turn fed back into dissecting room learning.”¹³⁷

¹³⁵ Hallam. 65

¹³⁶ Hallam. 74

¹³⁷ Hallam. 66

It is important to mention that the conceptual relationship between the Anatomy Museum and the dissecting room was also supported by the architectural layout. The close alignment of the museum and the dissecting room was enhanced with the opening of a doorway between them allowing the staff and the students to pass from one space to the other easily while working with the displays (Fig. 27).¹³⁸



Figure 33. Dissecting room in the Anatomy Department, Marischal College, University of Aberdeen, 2007

Source: Elizabeth Hallam, *Anatomy Museum: Death and the Body Displayed* (London: Reaktion Books, 2016), 68

In the space of the dissecting room, the body that was depersonalized and objectified in the mortuary became a “cadaver”, a body that was ready to be investigated by tactile and visual means. As the dissection and dismantling proceeded, the conception of the embalmed body as a person diminished and bodies began to be perceived “anatomically”. As Rachel Prentice indicates, the “ontological duality” of

¹³⁸ Hallam. 332

the body which refers to the condition of being both a “person” and a “thing”¹³⁹ is revealed in the dissecting room.

In the dissecting room, each table was used by a group of students. In the dissection session, students took turns to dismantle, identify and sense the anatomical parts while others members of the group read instructions from manuals, studied related diagrams, X-rays or other visual material or observed and discussed the dissection. The dissection procedure was organized according to the scholarly defined anatomical regions of the body which were, upper limb, lower limb, back, thorax, abdomen, pelvis and perineum, head and neck. In that sense, the dissection began with the upper limb and ended with the head and neck.¹⁴⁰ This process epitomizes the pedagogical interaction between the representational body in the student’s mind and the cadaver in real life explained in Chapter 2.2.1.

Dissection required multiple actions to occur simultaneously. It is a multi-sensory learning environment involving sight, touch and hearing. The major act of dissecting was accompanied by reading of instructions, observing visuals and examining models. The visual and textual knowledge provided by anatomical textbooks, plastic models and osteological specimens and also, prosections, which were the previously dissected parts by staff, guided the complex process of dissecting. The multiplicity of the activities and related material provided in manifold media combined with the tactile experience of dissection constituted the anatomical knowledge.¹⁴¹

In this context, a special attention must be payed to the engagement of the eye and the hand in the dissection room. The dissection sessions procured the development of a “sharp eye”, “trained hand” and “educated finger” together.¹⁴² Moving the argument one step further, Hallam wrote:

¹³⁹ Rachel Prentice, *Bodies in Formation: An Ethnography of Anatomy and Surgery Education* (Durham: Duke University Press, 2013).157 quoted in Hallam, *Anatomy Museum: Death and the Body Displayed*. 70

¹⁴⁰ Hallam, *Anatomy Museum: Death and the Body Displayed*. 71

¹⁴¹ Hallam. 74

¹⁴² Hallam. 207

“With practice the hands and eyes of the emerging expert would become so closely aligned that, according to Cooke, he would acquire an ‘eye at the tip of his finger’ – ‘digital eye’ that could see the deeper parts of the body by means of ‘tactile sensations’.”¹⁴³

The concept of “digital eye” is quite related to the notion of “medical gaze” described in Chapter 2.2.1. To be specific, it corresponds to the plurisensorial structure centering around senses of sight and touch, and the ability of making the invisible visible of the medical gaze. In the dissecting room, recurrent tactile contacts with cadavers accompanied by visual investigation, produced, developed and reinforced the anatomical knowledge. The trained activity of the hand and the eye operating through the body fostered anatomical visualization.

“Their (students’) extended navigation of bodily exteriors and interiors was educated into ‘skilled movement’, facilitating the visualization and remembering of anatomy.”¹⁴⁴

Here the concepts of “visualization” and “remembering” of anatomy are quite important. Regularly repeated bodily practices become skills through memory. The students performed dissections on a regular basis and each time their hands and eyes remembered their previous sensations and operated more skillfully. By that, the tactile and visual abilities were achieved. This remembering process is called as the “mnemonics of the body”¹⁴⁵ On the other hand, as defined previously, anatomical visualization is about piecing together anatomical information in mind to create a three-dimensional mental map of the body. In that sense, it is possible to call it simply as a process of “re-membering”. The relation between “remembering” and “re-membering” is an important argument of this study and further examined in Chapter 4.5.2.

¹⁴³“Future of the Medical Museum,” *The Lancet* 245, no. 6343 (1945): 376–77, [https://doi.org/10.1016/S0140-6736\(45\)90225-X](https://doi.org/10.1016/S0140-6736(45)90225-X), 376 quoted in Hallam, *Anatomy Museum: Death and the Body Displayed*. 207

¹⁴⁴ Hallam, *Anatomy Museum: Death and the Body Displayed*. 77

¹⁴⁵ Paul Connerton, *How Societies Remember* (Cambridge: Cambridge University Press, 1989)., 74 quoted in Hallam, *Anatomy Museum: Death and the Body Displayed*. 77

In addition to the act of dissection itself, the association of the hand and the eye is epitomized in another activity that took place in the dissection room. During the dissection sessions, the students were highly encouraged to make the drawings of the malformations and uncommon structures. Between the 1890s and 1940s students were supposed to fill standardized forms with sketches and brief descriptions of the body that they were dissecting. Students used watercolor and crayons to capture the three-dimensionality of the anatomical parts. The outcomes of the tactile and visual experience of dissecting was reflected on the drawing, which was also a tactile and visual practice. The drawings created by the students were temporarily displayed which provides another example to the display activities happening in the dissecting room. Dissection manuals specifically advised students to make drawings during the dissection because drawing enhanced the attention paid on the details and the memorability of them.¹⁴⁶ In that sense, drawing was a respected method for gaining and consolidating knowledge.

Anatomy Museum

Anatomy Museum was located right next to the dissecting room and there was an inner door connecting these two spaces (Fig. 27). The museum had a ground floor and an upper gallery running around the perimeter, covered with a glass-roof. Similar to the dissecting room, the museum sustained its nineteenth century structure. The extensive collection included human skeletal specimens, fluid preserved specimens of human tissues, modern plastic models, historical models, illustrations and old instruments. The ground floor was arranged as a “learning space”. The open-shelf display cases and study tables with chairs around clearly demonstrated this aspect of the museum. Also, there were desks with computers providing the students arrays of digital images of dissected body parts, X-rays, histology slides and videos

¹⁴⁶ Hallam, *Anatomy Museum: Death and the Body Displayed*. 209-210



Figure 34. Ground-floor bays and upper gallery of the Anatomy Museum, Marischal College, 2007.

Source: Elizabeth Hallam, “Disappearing Museums? Medical Collections at the University of Aberdeen,” in *Medical Museums: Past, Present, Future* (London: The Royal College of Surgeons of England, 2013), 44–59. 54

On the contrary, the gallery was a “frozen” and inaccessible display area, where only staff could enter. It was mainly used as a storage space for the collection of human bones. Apart from that, in the gallery there was an exhibit narrating the history of anatomy in Aberdeen.¹⁴⁷

¹⁴⁷ Hallam. 80



Figure 35. Technician's contact prints showing views of the gallery in the Anatomy Museum, Marischal College, University of Aberdeen, c. 1980s. Image cropped and edited by the author.

Source: Elizabeth Hallam, *Anatomy Museum: Death and the Body Displayed* (London: Reaktion Books, 2016), 325

The anatomical displays on the ground floor were related to, nonetheless different from those in the dissecting room. The displays in the dissecting room were temporary as the bodies of the donors could be kept for maximum three years from their death till their cremation or burial, whereas the specimens in the museum were on permanent display.¹⁴⁸ It could be argued that in terms of display, dissecting room was more dynamic, transforming and fluid compared to the static environment of the museum. The static and rigid nature of museum display may seem like a negative quality, but Bates favors museum over the dissecting room:

“Museums were particularly important to anatomy teaching, as they allowed more prolonged and careful study than the dissecting room, and availability of specimens could be guaranteed.”¹⁴⁹

Despite the scholarly charm of touching, cutting and exploring a “real” body in the dissecting room, the Anatomy Museum provided readily-prepared and permanently available material which was a great contribution to the learning process of the students.

Another difference was that in the dissecting room, the embalmed bodies were open and ready for any kind of tactile contact, even to manipulations like cutting, tearing, or teasing apart. Whereas, the specimens in the museum were “inaccessible to touch” in terms of being, delicate, fragile, too heavy to be moved from the shelves or rare.

¹⁴⁸ Hallam. 82

¹⁴⁹ Bates, “‘Indecent and Demoralising Representations’: Public Anatomy Museums in Mid-Victorian England.” 1

Above all, most of the specimens were contained in jars, which made them physically unavailable for tactile experience.¹⁵⁰

Despite these distinctions, there was a continuous interaction between the dissecting room and the museum. The architectural connection between the two spaces enhanced the mobility of the staff, students and objects. For instance material like plastic models were the common display elements of both spaces and related specimens of the museum were temporarily exhibited in the dissecting room. Even the dissecting tables and the study tables in the museum were conceptually related elements, integrating the Anatomy museum and the dissecting room.

Although all the spaces in the Anatomical Department were the parts of a whole, there was a special bond between the Anatomy Museum and the dissecting room. Both spaces aided students in terms of providing anatomical material for visual and tactile examination, leading them to build their “three-dimensional spatial knowledge of anatomy”.¹⁵¹ This underlines the fact that both spaces were essentially designed for “learning by doing”. On this subject Hallam wrote:

“At Marischal College both the dissecting room and the Anatomy Museum were key sites in which teaching staff encouraged students to learn by ‘doing’, through active and engrossing ‘hands-on’ participation.”¹⁵²

The pedagogical activities that took place in the museum and the dissecting room were mutually-complementary, supporting each other for the creation, dissemination and consolidation of anatomical knowledge. The students correlated the cadavers performatively studied in the dissecting room with the preserved specimens, models, diagrams and illustrations in the museum. Through the material in the museum, the aspects that were left unclear, ambiguous or missing after the dissection session were clarified and completed.

¹⁵⁰ Hallam, *Anatomy Museum: Death and the Body Displayed*. 82

¹⁵¹ Hallam. 79

¹⁵² Hallam.48



Figure 36. Ground floor displays and the gallery of the Anatomy Museum, Marischal College, University of Aberdeen, 2007

Source: Elizabeth Hallam, *Anatomy Museum: Death and the Body Displayed* (London: Reaktion Books, 2016), 80

In many aspects, Anatomy Museum presented a distinctive museum environment. Primarily, the idea of “open-shelf display cases” was an uncommon approach when other museum types and the common idea of a museum display are considered. As previously explained, tactile experience was highly valued in anatomical education. Therefore, the concept of “tactile display” was considered to be an important part of the learning process.¹⁵³ The ground floor of the museum was arranged as a study space consisted of open-shelf display cases which meant that the objects on display were available for tactile contact and moving. Like a library, the students could take an object from the shelf, bring it to the tables at the central space of the museum and study it thoroughly. Many other anatomical museums had similar approaches for encouraging the tactile engagement of the students with the material on display.

¹⁵³ Hallam.76

“Nevertheless, in all of these museums emphasis has been placed on tactile learning, and where there are glass cases, rather than open shelves, they are unlocked for students to closely examine their contents.”¹⁵⁴

The whole idea of “tactile display” is something quite unusual because in most cases, the museum displays are not to be touched, just allowing visual contact within certain limits. In that sense, the Anatomy Museum, and the anatomical museums in general, presented a different model of engagement with the display objects, beyond the common approach which is confined to vision-based activities, they incorporated the tactile sensation to the museum experience.

Another distinctive quality of the Anatomy Museum was its spatial context. In most of the museums, the subsidiary spaces such as the storage areas, workshops, study or lecture rooms and laboratories have been located within the limits of the space designated as museum. This refers to the interwoven condition of the exhibition galleries and the supporting spaces. For instance, the American Museum of Natural History as it was in 1920, included a lecture hall and laboratories which were embedded in the scheme of the exhibition galleries. (Fig. 37) The galleries housing different collections were dispersed all around the building and the spaces defined as the lecture hall and laboratories were interlaced with the galleries. On the contrary, the floor plan of the Anatomical Department of Marischal College as it was in 2009 presents a layout where the auxiliary spaces of the museum such as the museum store and the workshop were defined outside the contours of the space named as the “Anatomy Museum”. (Fig. 27) In the case of American Museum of Natural History, the term “museum” comprised all the exhibition galleries and the supporting spaces, whereas in Marischal College, “museum” only referred to the exhibition galleries. Within this context, it is possible to argue that the spatial configuration of the Anatomy Museum is the “inside-out” version that of the usual museum format. The spatial layout of the Anatomical Museum and its subsidiary spaces may seem less integrated just by looking at the floor plan, but indeed the activity scheme proves the

¹⁵⁴ Hallam.84

opposite. It could be argued that the placement of the supporting spaces, that have been commonly designed within the boundaries of the “museum”, outside the “museum”, paved the way for a more sophisticated layout in practice by allowing multiple interactions between distinct spaces and attributing unconventional qualities to those spaces.

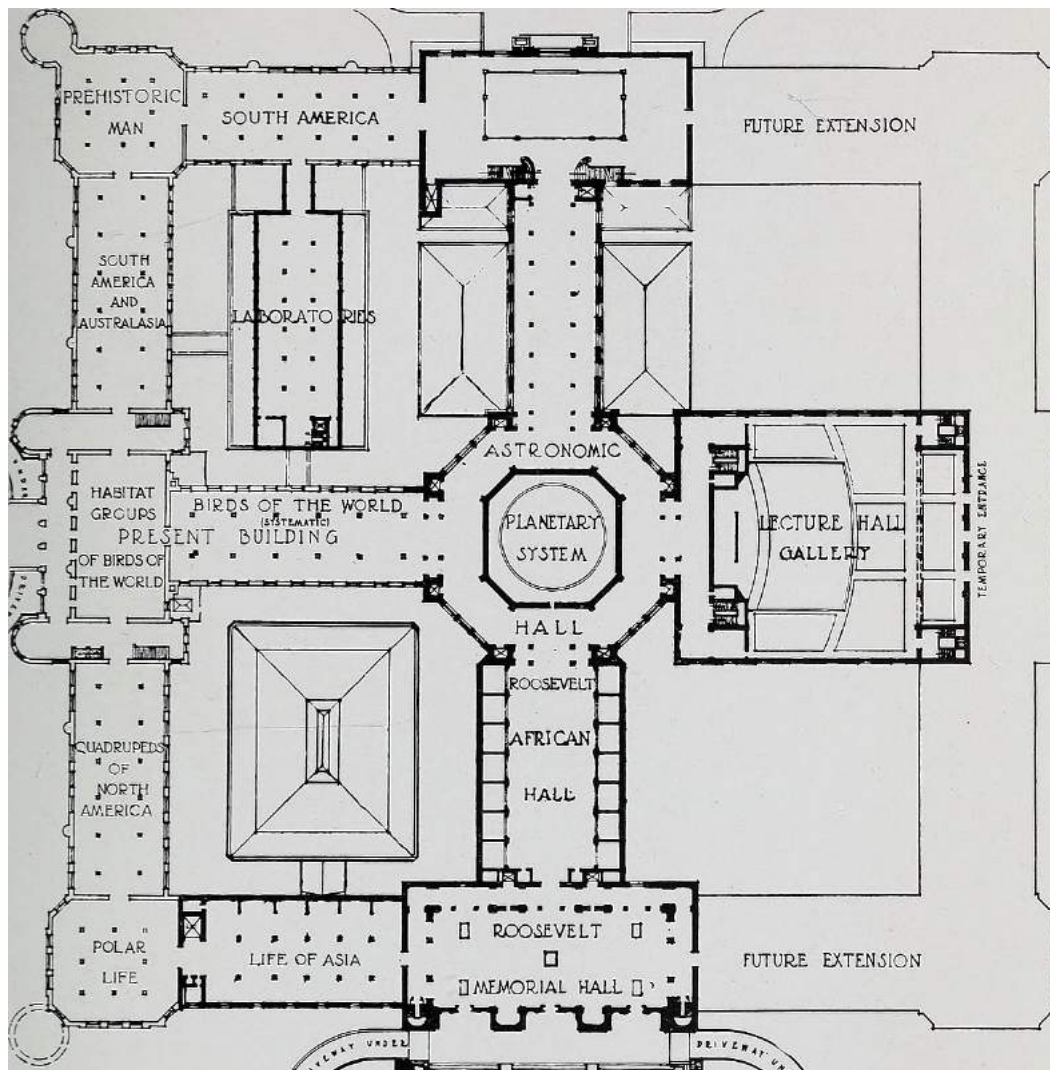

Figure 37. The plan drawing of the American Museum of Natural History as included in the Annual Report of the Trustees for the year 1920

Source: Annual report of the trustees of the American Museum of Natural History for the year (1920), Wikimedia Commons accessed July 8, 2020, [https://commons.wikimedia.org/wiki/File:Annual_report_of_the_trustees_of_the_American_Museum_of_Natural_History_for_the_year_\(1920\)_19179965490.jpg](https://commons.wikimedia.org/wiki/File:Annual_report_of_the_trustees_of_the_American_Museum_of_Natural_History_for_the_year_(1920)_19179965490.jpg)

Hans Ulrich Obrist remarks that “museum space is always in contact with other oscillating spaces and conditions.”¹⁵⁵ The case of the Anatomy Museum of the Anatomical Department in Marischal College epitomizes this argument. The analysis of the Anatomical Museum and the spaces around shows the complex relations between them. More importantly, it reveals the fact that the functioning of the museum space was dependent on the activities taking place in the surrounding spaces such as the dissecting room, mortuary, workshop and the museum store. Reciprocally, the practices in all these spaces were materially and conceptually connected to the Anatomy Museum. Regarding the importance of the supporting spaces for the museums, Ivan Gaskell wrote:

“Contrary to popular and even dominant academic opinion, exhibition galleries are not the heart of a museum. The heart comprises the storage areas and the collections they contain, the study rooms and laboratories in which those collections are investigated, the archival records that concern them, and the curators, conservators, and scientists who conduct and publish their research, whether in conjunction with exhibitions or not. Public galleries, while not exactly optional extras, are secondary.”¹⁵⁶

Although Gaskell’s argument may seem quite extreme, he frames well the essential role of the “secondary” spaces such as the workshop, storage, and laboratory for the sustenance of the museum.

Beyond these links, as implicitly mentioned throughout the subchapter, this study claims that under the medical gaze, the complex design of the anatomical education and consequently, the architectural program accommodating the educational practices, resulted in the transformation of the spaces other than the Anatomy Museum into display environments.

The orderly arrangement of the unused anatomical objects in the museum store; the models and specimens brought from the museum for demonstration and the projected

¹⁵⁵ Hans Ulrich Obrist, Vivian Rehberg, and Stefano Boeri, “Moving Interventions: Curating at Large,” *Journal of Visual Culture* 2, no. 2 (2003): 147–60, <https://doi.org/10.1177/14704129030022001>. 150

¹⁵⁶ Ivan Gaskell, “University and College Museums: Some Challenges,” *The Antioch Review* 74, no. 2 (2016): 228–36. 228

images of museum objects in the lecture theatre; the objects in the glass cabinet, illustrations on the wall and the osteological specimens brought from the museum in the science laboratory; temporary exhibits of the museum objects, the manifestation of the human body, alive, the students, and dead, the embalmed bodies, in the dissecting room are all different kinds of display, rendering these rooms spaces of display. Even the entrance corridor of the anatomical department became a display space by means of the reliefs and images on the wall and the skeletons mounted on the ceiling. Hallam commented on this subject as:

“The corridor was a display space leading to the museum and just as the museum has changed over time so has the corridor, conveying different impressions of the scope of anatomy.”¹⁵⁷



Figure 38. Entrance corridor, Anatomy Department, Marischal College, University of Aberdeen, c.1906

Source: Elizabeth Hallam, *Anatomy Museum: Death and the Body Displayed* (London: Reaktion Books, 2016), 202

¹⁵⁷ Hallam, *Anatomy Museum: Death and the Body Displayed*.54



Figure 39. Entrance corridor, Anatomy Department, Marischal College, University of Aberdeen, 2007

Source: Elizabeth Hallam, *Anatomy Museum: Death and the Body Displayed* (London: Reaktion Books, 2016), 54

In this “nexus of activities”, besides the display practice was not confined to the museum space, other practices took place in spaces outside of their usual ones. In particular, the extensity of the activities that were accommodated by the museum draw attention. As spaces other than the Anatomy Museum turned into spaces of display, the museum also gained the attributes of other spaces. The museum, which is known to be a space devoted to the exhibition of the objects, became a classroom and laboratory.¹⁵⁸

In addition to the prominent role of museum display in anatomical education, the design of the Anatomical Museum as a learning and study space underlines its pedagogical role. Open-shelf display cases, large study tables and computer equipped desks in the ground floor of the museum supports the attributed functions

¹⁵⁸ Referred to unpublished notes-Ayşen Savaş, Bologna Experience, 2016

of museum space as an “augmented classroom” and a laboratory for research and practice.



Figure 40. Ground floor of the Anatomy Museum in the Anatomy Department, Marischal College, University of Aberdeen, 2003

Source: Elizabeth Hallam, *Anatomy Museum: Death and the Body Displayed* (London: Reaktion Books, 2016), 93

The arguments regarding the transformation of the spaces surrounding the museum into display spaces and the museum space becoming a classroom and laboratory are epitomized in many other medical school complexes. The house-academy complex of William Hunter at Great Windmill Street and that of John Hunter in Leicester Square, discussed in Chapter 2.1.1, set good examples when their complex schemes of spaces and activities are considered. Medical School of McGill University¹⁵⁹,

¹⁵⁹ See Annmarie Adams, “Encountering Maude Abbott,” *Feminist Encounters: A Journal of Critical Studies in Culture and Politics* 2, no. 2 (2018): 1–17, <https://doi.org/10.20897/femenc/3889>.

Leiden University Faculty of Medicine¹⁶⁰ and Charité in Berlin¹⁶¹ are other prominent examples that could be further examined. (Fig.43)

According to the observations of the author, Berlin Museum of Medical History at the Charité (1899) still actively functions as a study space. In the museum, the study tables disposed in-between the parallel rows of display cases are currently used by the medical students for study, practice and research purposes. (Fig. 41-42)

Within this context, it is possible to argue that, although the advanced pedagogical setting of the Anatomical Department of Marischal College which centered around the spaces and activities of display does not sustain its original scheme today but the relations, conditions and acts created or redefined in this environment are still significant and valid. In line with this argument, Hans Ulrich Obrist states that:

“To explore how museums can be envisioned not as homogeneous spaces but as a site that satisfies a diversity of conditions so that, let’s say, the white cube, a laboratory and a space for intimate conversation can coexist.”¹⁶²

¹⁶⁰ See Merieke Hendriksen, Hieke Huistra, and Rina Knoeff, “Recycling Anatomical Preparations: Leiden’s Anatomical Collections,” in *Medical Museums: Past, Present, Future*, ed. Samuel JMM Alberti and Elizabeth Hallam (London: The Royal College of Surgeons of England, 2013), 74–87.

¹⁶¹ See Thomas Schnalke, “Tracing Life: The Berlin Museum of Medical History at the Charité,” in *Medical Museums: Past, Present, Future*, ed. Samuel JMM Alberti and Elizabeth Hallam (London: The Royal College of Surgeons of England, 2013), 130–43.

¹⁶² Obrist, Rehberg, and Boeri, “Moving Interventions: Curating at Large.” 150



Figure 41. A study table between the display cases in the Berlin Museum of Medical History at the Charité, sketch drawing made by the author, March 2019



Figure 42. A student studying in the Berlin Museum of Medical History at the Charité, sketch drawing made by the author, March 2019

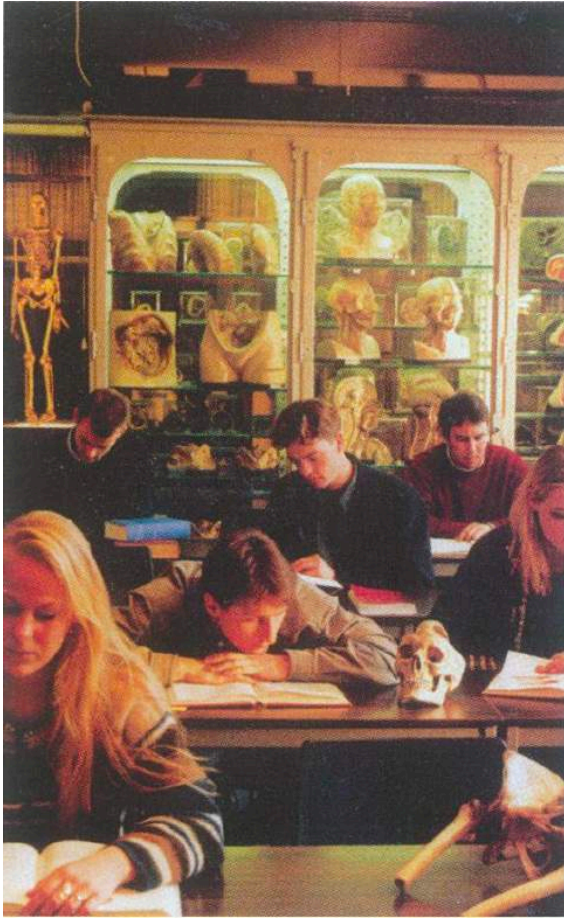

Figure 43. Postcard with Leiden University students surrounded by the anatomical collections in a lecture room, around 1990.

Source: Merieke Hendriksen, Hieke Huistra, and Rina Knoeff, “Recycling Anatomical Preparations: Leiden’s Anatomical Collections,” in *Medical Museums: Past, Present, Future*, ed. Samuel JMM Alberti and Elizabeth Hallam (London: The Royal College of Surgeons of England, 2013), 74–87, 86

2.3. Display of the Anatomical Body

2.3.1. Systems of Visual Display

“The only museum object, which by definition preserves its body, in better terms, which remains unchanged, is the body. As the body remains the same as a total entity, its study as an object changes in time and context.”¹⁶³

¹⁶³ It is stated by Ayşen Savaş in the report presented for the EU Project “La Specola” in February 2018, based on her studies in Bologna as a visiting fellow.

As Ayşen Savaş states, the special case with the display of the human body is the fact that human body does not change. Nevertheless, the methods to study the body continuously evolve. For centuries the updates and alterations in anatomical teaching and practice have given rise to the development of new languages, styles, representation methods and visualization instruments for the display of the bodily interiors. Manifold display methods visualizing the body in different ways have been devised and employed. The history of the anatomical display and the correlated visualization techniques is “tied to the desire to find secure knowledges, to find stable referents in relation to the messiness of human bodies.”¹⁶⁴ All the display methods developed so far have aimed to present the body in a different manner by offering a novel “way of seeing” for reading, interpreting and understanding the complex and intricate interiors of the body. These methods have emphasized distinct aspects of the human anatomy in order to serve for diverse purposes within the field of anatomy education and research. The anatomical body translated, abstracted and represented through different methods, serving for various learning modalities, led to the generation and dissemination of new knowledges.

Visual displays systematize the pedagogical training and constitute the basis of many educational theories such as that of Swiss pedagogue Johann Pestalozzi (1746-1827) who believed that “observation of objects themselves formed the best mode of teaching.”¹⁶⁵ Accordingly, anatomy education, research and practice depended, and still depends upon a variety of visual displays that involve diverse practices that render the human body observable and intelligible.

For centuries, various methods, techniques, and approaches have been employed for displaying the structure and the functioning of the human body. Besides, a great variety of materials have been used for anatomical displays including paper, wax, plaster, wood, and plastic to provide diverse visual, and in some cases tactile,

¹⁶⁴ Petra Kuppers, “Visions of Anatomy: Exhibitions and Dense Bodies,” *Differences* 15, no. 3 (2004): 123–56, <https://doi.org/10.1215/10407391-15-3-123.124>

¹⁶⁵ Berkowitz, “Systems of Display: The Making of Anatomical Knowledge in Enlightenment Britain.” 4

experiences. A constellation of interrelated material has served for pedagogical and research purposes. These displays have helped not only to the medical professionals but also others such as artists, biologists and natural philosophers learn to see both the tiniest and rarest parts and the overall composition of the human body and understand the human nature in all its dimensions.

Charles Bell introduced the concept of “system of visual display” through which the complex structure of the human body has been discovered, studied, and thought. In this system, displays that were materially and methodologically different from each other serving for different purposes within the broad scope of anatomy education, together formed the “complementary parts of a unified project.”¹⁶⁶ In 1814 Bell wrote in a letter that “whole system must be kept in full operation – preparations, drawings, models, cases, lectures, clinical lectures.”¹⁶⁷ It is important to underline the fact that Bell’s pedagogical system highly valued sensory experience. Especially, the major aim was to train the vision. Therefore, every component of the system was fundamentally visual. Although seeing was privileged, the display system was not limited to the sense of sight since Bell strongly advocated the training of the hand and the eye together, as elaborated in Chapter 2.2.1.

This system of display commonly constituted illustrated books, schematic chalk drawings done in classroom, wax models, preserved specimens in jars, paintings and sculptures, dissected bodies and also, living bodies. All these individual elements of display functioned together as parts of a system that was arranged in the particular setting of medical school complexes and for a particular objective, the comprehensive and orderly study of human anatomy.

Medical schools presented a system of the visual display where the anatomy museum constituted the heart. The major display environment of the anatomical body was the museum space. Nevertheless, the system was not confined to the museum as other

¹⁶⁶ Berkowitz. 1

¹⁶⁷ Charles Bell, *Letters of Sir Charles Bell, Selected from His Correspondence with His Brother George Joseph Bell* (London: John Murray, 1870). 220 quoted in Berkowitz, “Systems of Display: The Making of Anatomical Knowledge in Enlightenment Britain.” 2

spaces of anatomical scholarship such as the anatomical theatre, dissection room, lecture theatre, workshop, and laboratory were also parts of this system. All these spaces accommodated different kinds of display activities and, established various spatial and conceptual associations with the anatomy museum as discussed in Chapter 2.2.2 through the case of the Anatomical Department of Marischal College in the University of Aberdeen. In every space that was involved in the display system, different renderings of the human body were presented. Regarding that, Berkowitz wrote:

“In the early nineteenth century, drawings appeared in journals, books, and lecture halls. Museums containing preserved specimens and models were common. Lectures were sometimes given in the middle of museums so that the lecturer could illustrate his point. And, of course, actual bodies were displayed in dissection rooms, in which students would customarily watch a demonstrator perform a dissection.”¹⁶⁸

In fact, the system of visual display could be seen as a process in which the “body as a subject” transformed into a “body as an object.” The dead bodies brought to the mortuary became embalmed subjects, then cadavers in the dissecting room, and after then turned into specimens in the workshop to be exhibited in the museum. After spending some time in the museum, the “objectified” bodies were brought back to the workshop for maintenance, or carried to the dissecting room, lecture theatre or the laboratory for enhancing the learning process, whereas the unused ones were transferred to the museum store. Alberti wrote on this subject as follows:

“Human remains collected from elsewhere moved along the same acquisition routes as plants, animals, and books, in the process shifting from subject to object. As Ruth Richardson writes, this process demonstrated “the capacity of the human body itself to become artefact.” Natural history objects are prone to a comparable slippage between “natural” and “artificial” as they became material culture through the process of collecting, storage, and display.”¹⁶⁹

¹⁶⁸ Carin Berkowitz, “The Beauty of Anatomy: Visual Displays and Surgical Education in Early-Nineteenth-Century London,” *Bulletin of the History of Medicine* 85, no. 2 (2011): 248–78, <https://www.jstor.org/stable/44451985.253>

¹⁶⁹ Alberti, “Objects and the Museum.” 563

Based on this, it is possible to say that, in medical school complexes the dead bodies which were once alive, transformed into display objects for pedagogical purposes by travelling from one space to the other. In better terms, the body was *anatomized* by becoming a display object which constituted the essence of anatomical teaching. In addition to the literal conversion of the cadaver to specimen, the body was also translated into other media conceptually. As Hallam wrote, “body was sequentially transformed to demonstrate her anatomy into dissecting room subject, specimen, drawing, and photograph.”¹⁷⁰

Despite the drastic changes in the medical curriculum and the integration of new teaching modalities and modern technologies in anatomy education, displays continue to have an important role, and the “system of visual display” defined by Bell still preserves its validity.

2.3.2. The Art of Anatomy

Throughout history there have been intersections between art and anatomy in many aspects. The main reason behind these intersections is the common interest directed towards the human body, the pursuit of discovering and unfolding its complex structure and organization in order to extract the spectacular knowledge it embodies. The roots of this intertwined relational dynamic can be traced back to the Middle Ages where medicine was considered to be one of the seven mechanical arts, corresponding to the seven liberal arts that were: “*lanificium, armatura, navigation, agricultura, venatio, medicina, theatrica*”¹⁷¹. The interactions between both fields, art and anatomical science, and their main actors, the artist, and the anatomist, have reflected into the representation, display and study methods of the anatomical body. Therefore, to have a better understanding of the anatomical displays, it is necessary

¹⁷⁰ Hallam, *Anatomy Museum: Death and the Body Displayed*.213

¹⁷¹ Eilean Hooper-Greenhill, *Museums and the Shaping of Knowledge* (London: Routledge, 1992).41

to underline their artistic aspect and explore the interactions between art and anatomy in depth from the early medical illustrations to the present approaches.

The early anatomical illustrations and models, created during the Renaissance, had to satisfy the aesthetic needs of the viewer. They had to be “delightful”¹⁷², theatrical and emotional. This condition might have been a reflection of the cultural and intellectual framework of the era or could be directly explained by the urge to mask the disgust or irritation caused by the violence and the obscenity of the anatomical representations. The importance of this appealing character of the anatomical illustrations is expressed by Sappol as follows:

“The producers and audience for anatomical representation expected, even demanded, that anatomical illustration represent the human body morally, socially, theologically, theatrically, balletically, literarily, erotically as well as scientifically.”¹⁷³

¹⁷² Michael Sappol, *Dream Anatomy* (Bethesda MD and Washington DC: US Dept. of Health and Human Services, National Institutes of Health, National Library of Medicine, 2006).17

¹⁷³ Sappol.19



Figure 44. Anatomical illustration made by Stephen van Calcar from *De Humani Corporis Fabrica* by Andreas Vesalius (1543)

Source: Michael Sappol, *Dream Anatomy* (Bethesda MD and Washington DC: US Dept. of Health and Human Services, National Institutes of Health, National Library of Medicine, 2006), 13



Figure 45. Anatomical illustration made by Giulio de' Musi (1535-1553) from *Romanae archetypae tabulae anatomicae novis explicationibus* by Bartolomeo Eustachi (d. 1574)

Source: Sappol, 21

Following the statement of Kemp and Wallace, it is possible to epitomize the fruitful collaboration between artists and anatomists of the Renaissance era through many different cases. The drawings in the publications of well-respected anatomists were created by talented artists. For instance, the illustrations in Andreas Vesalius' *De Humani Corporis Fabrica* (1543)¹⁷⁴ were drawn by Jan Stephan Van Calcar, who was the student of famous Italian painter Titian.¹⁷⁵

¹⁷⁴ Andreas Vesalius as a prominent figure in anatomical science and his influential treatise *De Humani Corporis Fabrica* are discussed in detail in Chapter 3.

¹⁷⁵ "Part V-Animating Bodies, Exhibition Gallery Guide," *Paper Worlds: Printing Knowledge in Early Modern Europe* (Harvard University, 2010).

The actors of both fields, artists and anatomists, chose to explore and study the human body by means of “dissecting cadavers.” As stated by Schumacher, many artists of Renaissance such as Verrocchio, Donatello, Mantegna, Raphael, Boticelli and Michelangelo were highly interested in the cadaveric dissections.¹⁷⁶ These artists not only made the illustrations of the dissected bodies, “that were then recreated into prints and studied by medical students,”¹⁷⁷ but also performed dissections themselves.(Fig.46) Among them, Leonardo da Vinci (1452-1519) appears as a prominent figure, “who is said to have dissected more than 30 bodies.”¹⁷⁸ The intense relationship between anatomy and art is redefined by Da Vinci in his anatomical manuscripts as follows:

“...you, who wish with words to demonstrate the figure of man with all the aspects of his bodily parts, must renounce that opinion, because the more minutely you describe your object, the more you will confound the mind of the reader, and the more impossible will you render knowledge of the thing described. It is therefore necessary both to depict and to describe.”¹⁷⁹

¹⁷⁶ Gert Horst Schumacher, “Theatrum Anatomicum in History and Today,” *International Journal of Morphology* 25, no. 1 (2007): 15–32, <https://doi.org/10.4067/S0717-95022007000100002>. 17

¹⁷⁷ Marisa Satsia, “Inner Space: The Evolution of the Representation of the Human Body in Art and Science” (Bachelor Thesis, The University of Dundee, 2014). 13

¹⁷⁸ Schumacher, “Theatrum Anatomicum in History and Today.” 17

¹⁷⁹ A.M. Brizio, ed., *Scritti Scelti Di Leonardo Da Vinci* (Turin, 1952).514-515 quoted in Ferrari, “Public Anatomy Lessons and the Carnival: The Anatomy Theatre of Bologna.”56



Figure 46. Bartolomeo Passerotti, Michelangelo Conducting an Anatomy Lesson, ca. 1570.

Source: Fredrika Jacobs, “(Dis)Assembling: Marsyas, Michelangelo, and the Accademia Del Disegno,” *The Art Bulletin* 84, no. 3 (2002): 426–48, <http://www.jstor.org/stable/3177307>. 439

Via producing extremely precise anatomical drawings, the “artist-anatomist Leonardo Da Vinci”¹⁸⁰ provided comprehensive and accurate anatomical knowledge both to the field of art and science. His anatomical drawings propounded two essential aspects: they generated the act of “deep seeing” through which the inner structure and mechanism of the body could be understood, and they provided a way of “capturing and isolating” the fragments of the body until the invention of X-rays and MRI¹⁸¹. In alternative terms, he mastered the perception of the anatomical body through his redefinitions of “seeing” and “visualizing” which not only inspired the future technologies, but also enlightened the hidden interiors and the intricate details of the body.

Renowned Italian artist, Michelangelo (1475-1564), appears as another important figure regarding the strong bond between art and anatomy. Michelangelo’s life-long

¹⁸⁰ Satsia, “Inner Space: The Evolution of the Representation of the Human Body in Art and Science.”¹⁵

¹⁸¹ Satsia.²²

engagement with anatomy commenced with his attendance to public dissections¹⁸² during his early teen years. Later, he carried out cadaveric dissections himself, published an anatomy book for the artists and collaborated with anatomists by means of creating the illustrations in medical/anatomical texts. In his highly cited article, Garabed Eknayan reveals Michelangelo’s specific interest in kidney structure and function.¹⁸³ He draws attention to Michelangelo’s impressive fresco on Sistine Chapel in Vatican and argues that:

“...the kidneys as the organs that separate solid from liquid were probably familiar to Michelangelo, if not from his own studies then at least at second hand, and would constitute an appropriate symbolic backdrop for the Sistine Ceiling scene on Separation of the Waters from the Firmament.”¹⁸⁴

The smart metaphorical relation established between the form and function of the kidneys and the theme of the biblical scene, “Separation of the Waters from the Firmament,” underlines Michelangelo’s passion towards anatomy and embodies the intense interaction between anatomical science and the artistic creation.



Figure 47. Separation of the Waters from the Firmament from Last Judgment (1536–1541) by Michelangelo, Sistine Chapel, Vatican

Source: Garabed Eknayan, “Michelangelo: Art, Anatomy, and the Kidney,” *Kidney International* 57 (2000): 1190–1201. 1192

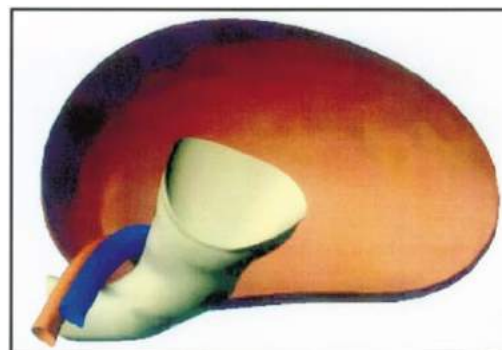

Figure 48. Computer-assisted removal of the figures showing kidney shaped mantle of the Creator, color highlighted version

Source: Eknayan, 1192

¹⁸² The concept of public dissections is elaborated in Chapter 3.3.

¹⁸³ Garabed Eknayan, “Michelangelo: Art, Anatomy, and the Kidney,” *Kidney International* 57 (2000): 1190–1201. 1190

¹⁸⁴ Eknayan. 1199

Renaissance not only introduced important figures in the intersection of art and anatomy, but also presented “a predominant symbol of art”, Venus, which was also re-presented as an anatomical figure.(Fig. 49-50) Venus originally expresses “beauty, desire, fecundity” and “a synecdoche of beautiful art”¹⁸⁵. Via composing “beauty and utility”¹⁸⁶ in itself, the Anatomical Venus not only brings together art and science, but also provides a dialogue between the physicality of the human body and the sublimity of nature¹⁸⁷. Thereby, the Anatomical Venus was beyond being a ¹⁸⁸mere instrument for medical education, it was a novel intersection of art and anatomy. As stated by Messbarger, the Anatomical Venus introduced a “more perfect mix of *bella e utile*”, that presents an instructive figure to the viewers in combination with a certain aesthetic appeal¹⁸⁹. The idea of creating objects for anatomical scholarship with artistic qualities was not limited to the concept of Anatomical Venus, many life-size male and female models with “canonical poses and pathos” made reference to the “masterworks of the art historical canon” dying warriors, reclining river gods, voluptuous goddesses, and rapturous Christian saints.”¹⁹⁰

¹⁸⁵ Rebecca Messbarger, “The Re-Birth of Venus in Florence’s Royal Museum of Physics and Natural History,” *Journal of the History of Collections* 25, no. 2 (2012): 1–21, <https://doi.org/10.1093/jhc/fhs007.4>

¹⁸⁶ Messbarger.14

¹⁸⁷ Joanna Ebenstein, “Ode to an Anatomical Venus,” *WSQ: Women’s Studies Quarterly* 40, no. 3–4 (2013): 346–52, <https://doi.org/10.1353/wsq.2013.0021.346>

¹⁸⁸ Martin Kemp and Marina Wallace, *Spectacular Bodies: The Art and Science of the Human Body From Leonardo to Now* (London: Hayward Gallery Publishing, 2000).

¹⁸⁹ Messbarger, “The Re-Birth of Venus in Florence’s Royal Museum of Physics and Natural History.”¹⁶

¹⁹⁰ Messbarger.14



Figure 49. The Birth of Venus by Sandro Botticelli (1486), exhibited in Uffizi Gallery, Florence.

Source: Rebecca Messbarger, "The Re-Birth of Venus in Florence's Royal Museum of Physics and Natural History," *Journal of the History of Collections* 25, no. 2 (2012): 1–21, 17



Figure 50. Anatomical Venus model in Museum of Natural History in Florence

Source: Rebecca Messbarger, "The Re-Birth of Venus in Florence's Royal Museum of Physics and Natural History," *Journal of the History of Collections* 25, no. 2 (2012): 1–21, 2

Unlike the remark put on the notions “beauty” and “aesthetic appeal” during the 16th century, 17th century brought the dominance of “scientific method” which underlined the hegemony of “systematic observation, measurement, experiment as well as formulation, testing, and modification of hypotheses”¹⁹¹. Although their collaboration continued at a certain level, 17th century set boundaries between the anatomist and the artist. Since the period was about truth and realism, the playful approaches towards the cadaver were abandoned and the dissected bodies were presented “in harshly realistic detail”¹⁹². As stated by Sappol, the contribution of the artist by means of the “fantasy architecture and landscapes for the anatomical figures to frolic in” was not accepted and the humorous/spiritual expressions of the body were subtracted and the whole representational space was dominated with the direct expression of its structure.¹⁹³

18th century maintained the anatomical realism of 17th century, and it also witnessed the development of anatomical universalism during 1830s and ‘40s. Sappol exemplifies anatomical universalism with the style of Gray’s Anatomy and describes it as “the most widely circulated twentieth-century anatomies”. The domination of both anatomical approaches put an end to the theatrical and ornamental elements. They manifested the complete division of science and art referring alternately “the truth of the body and the physical universe” and “everything else”.¹⁹⁴

¹⁹¹ Maria da Piedade Aldinhas de Freitas Ferreira, “Embodied Emotions: Observations and Experiments in Architecture and Corporeality” (PhD Thesis, University of Lisbon, 2015). 98

¹⁹² Sappol, *Dream Anatomy*. 28

¹⁹³ Sappol. 25

¹⁹⁴ Sappol. 48

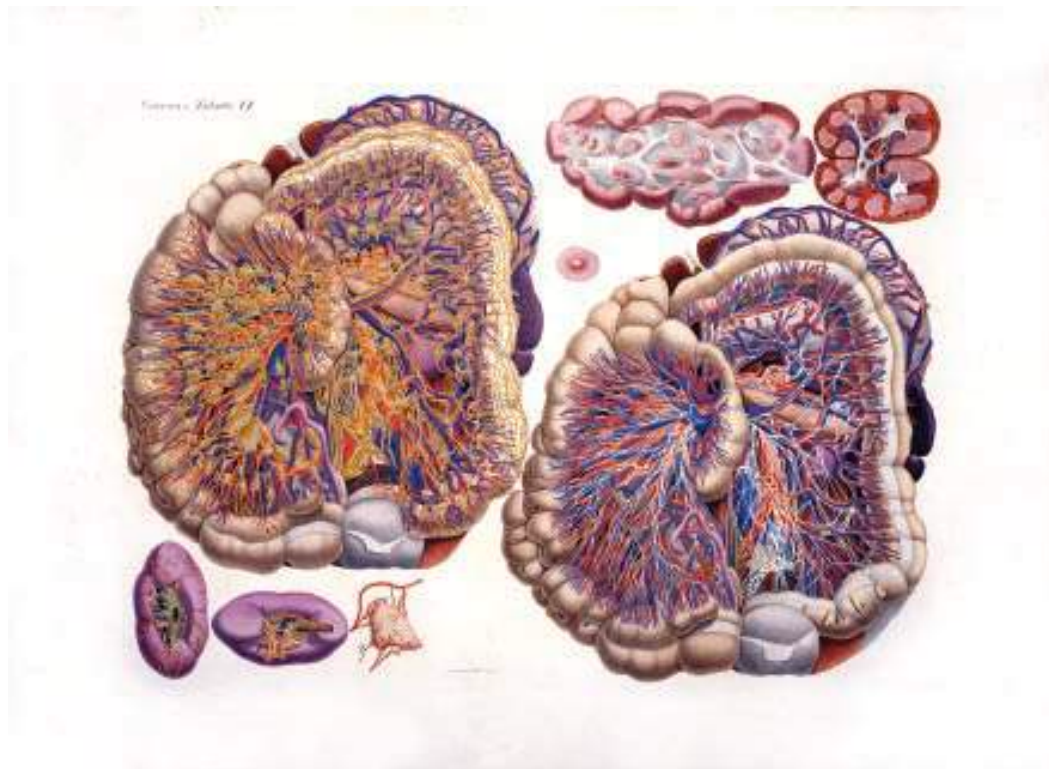

Figure 51. Realistic illustration made by Antonio Serantoni (1755-1815) from *Anatomica Universale* by Paolo Mascagni (1780-1837)

Source: Michael Sappol, *Dream Anatomy* (Bethesda MD and Washington DC: US Dept. of Health and Human Services, National Institutes of Health, National Library of Medicine, 2006), 49

The rise of science and medicine during the 17th-18th centuries reveals an overlapping timeline with the institutionalization of art. In the art academies, anatomical approaches were specialized as a separate branch in which the playful and fantastic expressions continued to be employed. In alternative terms, the anatomical study/artwork began to be considered as a common genre of art. However, the anatomical representation was acknowledged as a distinct concept detached from both scientific drawings and works of fine art.¹⁹⁵

The early 19th century highlights Sir Charles Bell who was an artist, anatomist and teacher pioneering his contemporaries in terms of acknowledging fine arts as a prominent tool for teaching anatomists, artists and surgeons. He not only promoted

¹⁹⁵ Sappol. 52

the artist to learn anatomy and use anatomical knowledge in their artworks, but also encouraged the anatomists and surgeons to draw, paint and make models to train and enhance their visual and tactile abilities. He claimed that the combination of anatomy and fine arts in the teaching/learning environment was critically important since “disciplining hand and eye” was essential for both fields.¹⁹⁶ Berkowitz explains the approach of Bell as follows:

“Creating anatomical models and drawings was thought to discipline the surgeon’s hand, while the study of anatomy and comparative anatomy would discipline the artist’s eye. And for Bell, beauty made drawings into better pedagogical tools.”¹⁹⁷

Among these processes, Bell prioritized “the art of anatomical preparation” as the most influential practice which stands at a distinct position compared to the “exercise of the scalpel”. Compared to the practices carried out in the dissecting room and the surgical theatre, the preparation making process provided the medical students a larger period of study, helping them to develop and improve manual skills in a more effective way.¹⁹⁸

¹⁹⁶ Berkowitz, “The Beauty of Anatomy: Visual Displays and Surgical Education in Early-Nineteenth-Century London.”

¹⁹⁷ Berkowitz. 248

¹⁹⁸ Berkowitz. 264



Figure 52. Illustration by Paolo Morgari in Francesco Bertinatti, *Elementi di anatomia fisiologica applicata alle belle arti figurative*. Turin, 1837–1839. Lithograph. National Library of Medicine.

Source: Michael Sappol, *Dream Anatomy* (Bethesda MD and Washington DC: US Dept. of Health and Human Services, National Institutes of Health, National Library of Medicine, 2006), 52

From the early methods to the present approaches, the understanding towards the relationship of anatomy and art had developed according to the intellectual perspective of the corresponding time. However, the popular touring exhibition *Körperwelten* (Body Worlds), having its initial exposition in 1995 and was shown in many parts of the world so far, presents a reversed orientation within this timeline and reveals an effort of recalling the early traditional approaches. It focuses on the display of the bodies and body parts preserved through the technique of “plastination”¹⁹⁹ developed by Gunther von Hagens, a German researcher from the Institute of Anatomy at the University of Heidelberg, who is also the creator of the

¹⁹⁹ Plastination technique is explained in Chapter 2.3.4.

exhibition. In terms of introducing the “aesthetic and instructive presentation of body’s interior” and making it as available as possible to the gaze of the viewer, Bodyworlds aims to “teach anatomy through art.”²⁰⁰

The exhibition reflects the long tradition of “anatomy art” in terms of comprising anatomical bodies with theatrical qualities that seem like frozen moments of activities such as running, swimming or playing chess. In addition, it includes bodies in “art historical poses” or imitating the famous artworks like *Le Penseur* by Rodin.²⁰¹ Although plastination is a new technique that brings a different perspective to the integration of art and anatomy, the approach of von Hagens is described as “recovering an old style disturbing medical-anatomical imagination”²⁰² and criticized as a “producer of kitsch”²⁰³.

²⁰⁰ Koppers, “Visions of Anatomy: Exhibitions and Dense Bodies.” 127

²⁰¹ Canadelli, “‘Scientific Peep Show’: The Human Body in Contemporary Science Museums.” 162

²⁰² Canadelli. 162

²⁰³ Peter Moeschl, “Images of the Body: On Sensory Perception in Medicine and in Everyday Life,” in *ReMembering the Body*, ed. Hortensia Völckers and Gabriele Brandstetter (Ostfildern-Ruit: Hatje Cantz Publishers, 2000), 286–300. 298



Figure 53. Gunther von Hagens, Body Worlds Exhibition, “Skinned Man.” 1997–present.

Source: Petra Kuppers, “Visions of Anatomy: Exhibitions and Dense Bodies,” *Differences* 15, no. 3 (2004): 123–56, 132

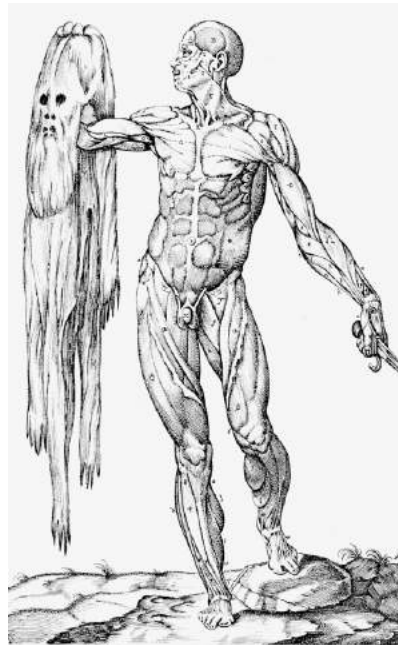

Figure 54. Figure of the flayed muscle man holding his skin and flaying knife by Gaspar Becerra in *Historia de la Composicion del Cuerpo Humano* by Juan Valverde de Amusco. (1556)

Source: Garabed Eknoyan, “Michelangelo: Art, Anatomy, and the Kidney,” *Kidney International* 57 (2000): 1190–1201, 1195



Figure 55. Saint Bartholomew holding a flayed skin from Last Judgment (1536–1541) by Michelangelo, Sistine Chapel, Vatican

Source: Eknoyan, 1193

20th century re-presents the integration of art and science within the scope of “sci-art movement.” Sci-art refers to creative and intellectual partnerships between the arts and sciences, using art to communicate science in an alternative manner or vice versa. The emergence of this period corresponds to the development of X-ray, MRI, CAT scans, electron microscopes and such technologies after the Second World War. The new form of visualizations, abstractions and representations of the human body brought by these medical technologies became a point of interest for the art world. Within this context, artists who choose to engage with science and create artworks that suggest alternative ways of seeing and reflect human experience have appeared.²⁰⁴ Rooted from the scientific potentials, contemporary artists have been

²⁰⁴ Karen Ingham, “The Anatomy Lesson of Professor Moxham,” in *Anatomy Live: Performance and the Operating Theatre*, ed. Maaike Bleeker (Amsterdam University Press, 2008), 75–91.

embraced the idea of acknowledging the human body in its most radical way which is expressed by Satsia as follows:

“Just like artists in the past, these contemporary artists see no boundaries. They pursue universal, cultural questions that break the disciplinary boundaries, explore what possibilities modern science can offer to their practice and collaborate with medical researchers and scientists. Science raises questions of ‘how’, while art investigates the reasons ‘why’.”²⁰⁵

For instance, in her project *Viral Landscapes* (1988-89) the artist Helen Chadwick dismembers the microscopic cell visuals of her body parts such as her mouth, vagina, ear and relocates them within landscape compositions. Chadwick benefits from the computer-imaging technology while bringing the separate photographs of her cellular body together with reference to the pattern she defines within the landscape imagery. She expresses the focus of her work via denoting the transformation/reshaping of the body as “a viral condition in the landscape.”²⁰⁶



Figure 56. *Viral Landscapes*, Helen Chadwick, 1988-89

Source: Marisa Satsia, “Inner Space: The Evolution of the Representation of the Human Body in Art and Science” (Bachelor Thesis, The University of Dundee, 2014), 40

Another artist De Menezes, who is in the pursuit of using the potentials of modern biology in the world of contemporary art, introduces biotechnology as new art media

²⁰⁵ Satsia, “Inner Space: The Evolution of the Representation of the Human Body in Art and Science.”38

²⁰⁶ Satsia.40

along with her practice in research laboratories. She underlines her efforts of including biological material into the artworld as a particular discourse through the “novel ways of representation and communication” offered by DNA, cells and proteins, etc. In her work “Functional Portraits”, the artist and other contributors perform a series of acts such as playing an instrument or drawing during which she analyzes the activities of brains via utilizing functional magnetic resonance (fMRI) scans.²⁰⁷

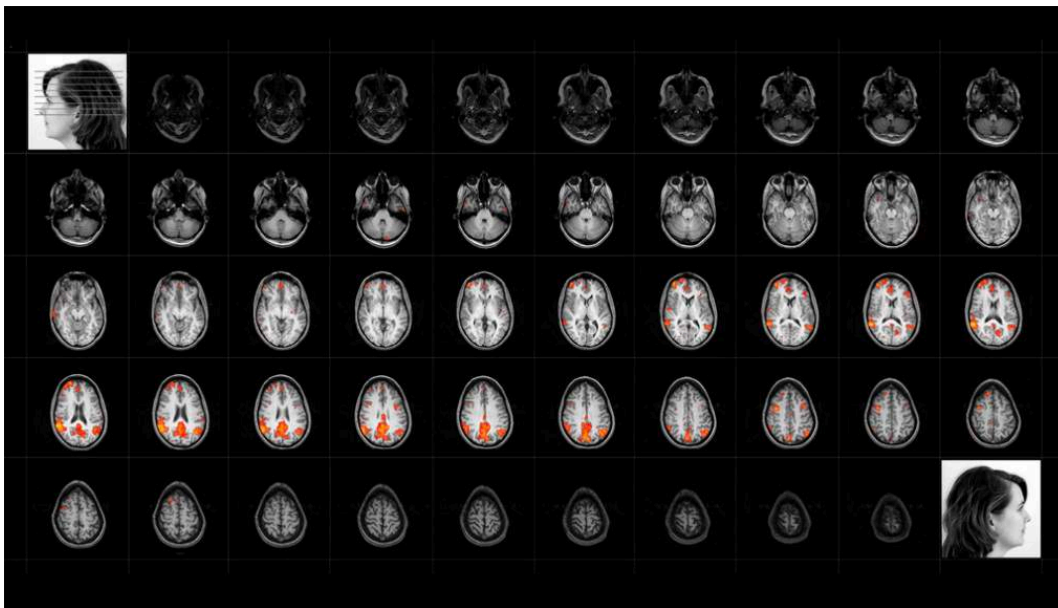

Figure 57. Functional Portrait: Self Portrait while drawing, Marta De Menezes, 2002

Source: Marisa Satsia, “Inner Space: The Evolution of the Representation of the Human Body in Art and Science” (Bachelor Thesis, The University of Dundee, 2014), 43

Another work that uses fMRI technology is the project developed by architect, artist, and theorist Marcos Novak entitled “Allobrain”. In the project, he uses his own fMRI scans to generate an interactive environment. In this simulated environment, it is possible to experience the movement of synaptic flow inside the human brain which plays a significant role in cognition process.²⁰⁸

²⁰⁷ Satsia.43

²⁰⁸ John Thompson et al., “The Allobrain: An Interactive, Stereographic, 3D Audio, Immersive Virtual World,” in *CHI Conference Workshop on Sonic Interaction Design*, 2008.

Novak’s work has specific importance for this thesis, as it relates the deep-seated art-anatomy alliance to architecture. In better terms, the project creates an inspiring conversation between art, science, and architecture. The architectural quality of Allobrain is expressed by the project team as follows:

“The structural component of the fMRI data provides an intricate spatial architecture, which is rendered visually as a navigable space that can be experienced as a world.”²⁰⁹

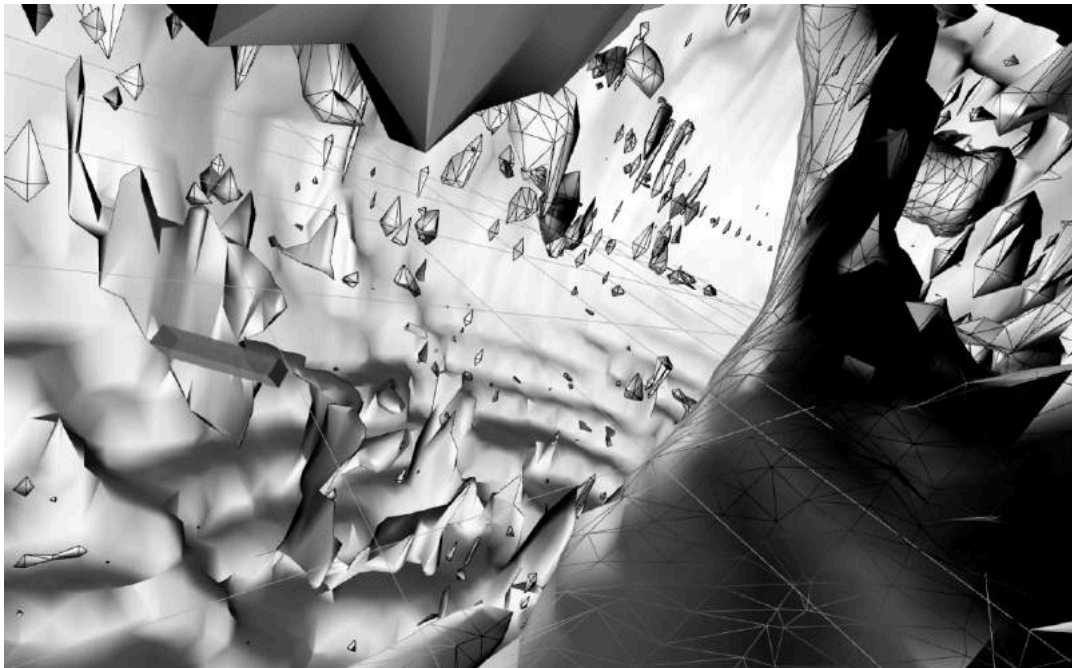

Figure 58. Exploring fMRI data inside the AlloBrain

Source: John Thompson et al., “The Allobrain: An Interactive, Stereographic, 3D Audio, Immersive Virtual World,” in *CHI Conference Workshop on Sonic Interaction Design*, 2008.

²⁰⁹ Thompson et al.

2.3.3. Multimedia Mapping of the Body

The displays in the “system” were produced through interrelated media in order to constitute and disseminate anatomical knowledge in an effective way. Anatomical scholarship relied on these displays and the multifaceted associations between them.

In this context, Hallam wrote:

“...students traced relationships between anatomical materials, finding intermedial connections- connections between anatomical parts rendered in different media including preserved specimens, plastic models, printed illustrations, diagrams and photographs.”²¹⁰

In this complex system of display that centered around the anatomy museum, the human body is exhibited through drawings, photographs, models and diagrams. Since the late 19th century the “intermedial display”²¹¹ of anatomy has been promoted by museum authorities and leading medical scholars. In the anatomy museums the specimens prepared from dissected cadavers are brought together with the drawings, photographs and models to display a single material: the human body. With the use of multiple media, the embodiment of all the perceptions and knowledge about the body take place in the museum space. In a way the human body dissolves into its representations in manifold media and the representations generate the idea of a “real”²¹² human body. Hallam describes this condition as follow:

“...“real” body, mediated by drawings, photographs or models, typical of the anatomical tradition. On the other hand, the real body is today gradually disappearing to leave room for digital, synthetic and virtual images of the body.”²¹³

²¹⁰ W.H. Flower, “Note on the Construction and Arrangement of Anatomical Museums,” *Journal of Anatomy and Physiology* 9, no. Pt 2 (1875): 259–62., 260 quoted in Hallam .53

²¹¹ Hallam, *Anatomy Museum: Death and the Body Displayed*.²¹²

²¹² The concept of “reality” is further discussed in Chapter 2.3.4.

²¹³ Canadelli, ““Scientific Peep Show’: The Human Body in Contemporary Science Museums.”



Figure 59. Wax model of a dissected uterus with twins, photograph by Saulo Bambi.

Source: Rebecca Messbarger, “The Re-Birth of Venus in Florence’s Royal Museum of Physics and Natural History,” *Journal of the History of Collections* 25, no. 2 (2012): 1–21, <https://doi.org/10.1093/jhc/fhs007>, 13



Figure 60. Engraving of a dissected uterus with twins by Charles Grignion after Jan van Rymdyk, 1751

Source: Rebecca Messbarger, 14

“The spatial and conceptual drawing together of specimen and image was a display strategy favoured among museum conservators. William Flower...a great authority on museums, was critical of arrangements that separated specimens from drawings and casts, advising that related items should be located together ‘in one spot’ to provide a ‘connected view’ of them and to allow direct comparison of ‘objects which must necessarily throw light upon each other.’”²¹⁴

The display arrangement advocated by Flower in 1875, focusing on the grouping of the objects not according to their media but to their content is still an accepted approach and implemented today in many museums such as the Berlin Museum of Medical History at the Charité. In Fig.61, it is seen that objects in different media

²¹⁴ Hallam, *Anatomy Museum: Death and the Body Displayed*.212

such as skeletons from deceased bodies, diagrams, drawings and photographs showing the human spine and spinal diseases were compiled to provide a complete understanding of the body part in question.



Figure 61. Berlin Museum of Medical History at the Charité, 2016, photograph by Laura Fiorio

Source: Hannah Gregory, “Missing Parts in the Collective Memory,” 100 Years of Now Journal, 2016, <https://journal.hkw.de/en/fehlende-teile-im-kollektiven-gedaechtnis/>.

Even though the anatomy museum is the main display setting of the anatomical body, the other spaces involved in the “system” also epitomize the concept of intermedial display. Plastic models, specimens and illustrations are displayed together in the lecture theatre, science laboratory and museum store. In the dissecting room, in addition to these objects, the demonstration of the dissected cadavers presents another form of display of the human body. (Fig. 62-63)

Within this context, it is possible to say that the sophisticated “system of display” provided and still provides a “multimedia mapping of the body”²¹⁵ for the purpose

²¹⁵ Medical Museums: Past, Present, Future, ed. Samuel JMM Alberti and Elizabeth Hallam (London: The Royal College of Surgeons of England, 2013), 9

of enhancing the anatomical scholarship. Through the visual displays that manifest the human anatomy in manifold media, the body is “mapped”, and this constitutes the essence of anatomy education.



Figure 62. Dissecting room of St. Thomas' Hospital, London, 1886

Source: Elizabeth Hallam, *Anatomy Museum: Death and the Body Displayed* (London: Reaktion Books, 2016), 209

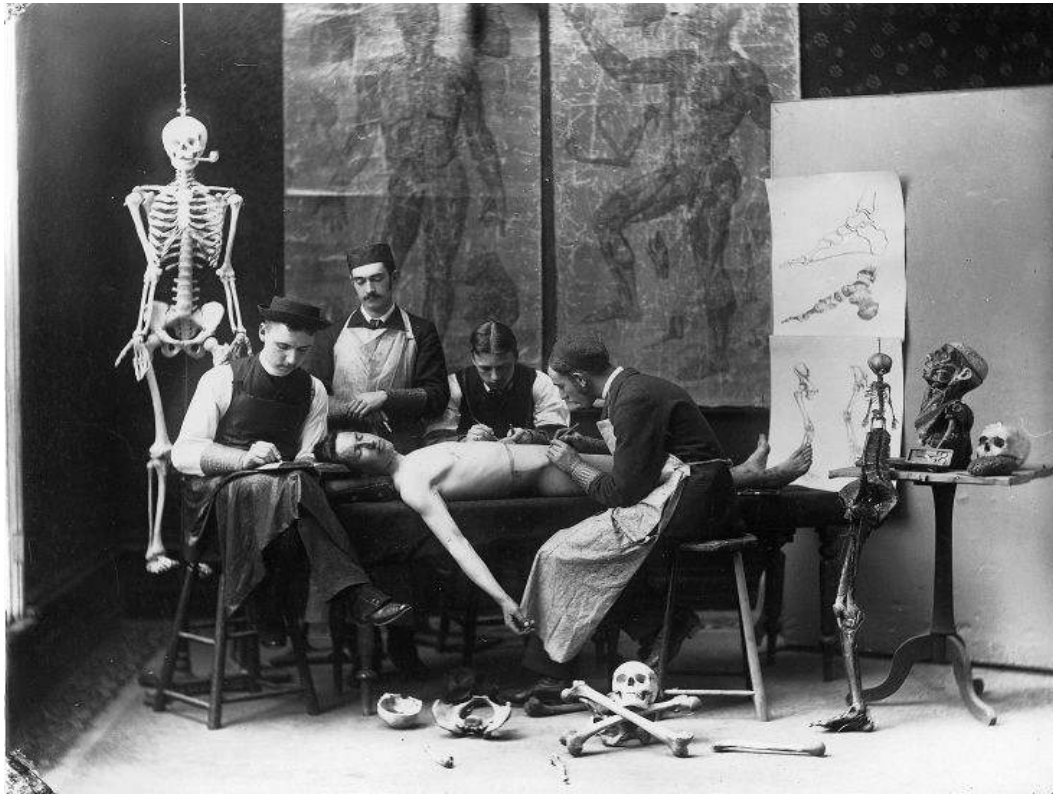

Figure 63. Anatomy study in McGill Medical School, 1884

Source: Anna Dysert, "Resurrecting the History of Body-Snatching at McGill," McGill Library Blogs, 2017, <https://blogs.library.mcgill.ca/osler-library/history-of-bodysnatching/>.

2.3.4. "Real" and Representational Bodies

In anatomy museum "the object itself" and "its representations" are exhibited together which is a quite particular display condition for the museum collections. The wet and dry specimens prepared through the dissection of actual bodies are displayed alongside illustrations, plastic, wax or wooden models, photographs and diagrams representing the human body. It is something like displaying the drawings, photographs and models of a building, together with the building itself inside a museum space.

Ancient and medieval anatomical treatises mainly composed of text descriptions of the body. Illustrations were very rare and when included, they were made quite schematic and rough as they were seen as secondary elements supplementing the text.²¹⁶ *De Humani Corporis Fabrica* by Vesalius “marks a turning point in the history of anatomical representation.”²¹⁷ It was the first time when an anatomical treatise comprised highly elaborate illustrations of the dissected bodies and body parts. By his masterpiece, Vesalius put forward the fact that the complex interior of the body could not be just described, it had to be shown.²¹⁸ In addition, Vesalius strongly advocated the cadaveric dissections for anatomical scholarship and initiated the tradition of public dissections, as discussed in Chapter 3.3. With the highly influential thoughts of Vesalius, anatomical illustrations together with the cadaveric dissections became the principal ways of “showing” the anatomical structure of the human body.

In that sense, it is possible to say that, since the early days of anatomy, anatomy education has depended on the combination of cadaver dissection and anatomical illustration. Cadaver dissection on its own has never been enough for a thorough anatomical training, thus anatomical illustrations have always supported the teaching. The two-dimensional representations provided an in-depth understanding of the human anatomy, helping the students to conceptualize the form and structure of the organs. Without the illustrations, the complex physiology of the body would be inconceivable. To communicate their empirical findings, anatomists relied on the accuracy and craft of their drawings. Therefore, anatomical illustration is commonly viewed as “mediated knowledge.”²¹⁹ The sophisticated anatomical drawings of great artists and anatomists were considered as “a derived form of knowledge - idealized representations of real bodies.”²²⁰

²¹⁶ Sappol, *Dream Anatomy*. 12

²¹⁷ “Part V-Animating Bodies, Exhibition Gallery Guide.” 92

²¹⁸ Sappol, *Dream Anatomy*. 12

²¹⁹ José van Dijck, “Digital Cadavers and Virtual Dissection,” in *Anatomy Live: Performance and the Operating Theatre*, ed. Maaïke Bleeker (Amsterdam University Press, 2008), 29–47. 29

²²⁰ Dijck. 29

Cadaveric dissection and anatomical illustrations constituted an inseparable whole for anatomy education. As dissection was not sufficient without the anatomical illustrations, illustrations were not enough without the dissection.

The problem with the dissection was that the human body was subject to irresistible organic change, meaning that the dissected cadavers could not persist for further examination, they decayed expeditiously. Consequently, methods to preserve dissected bodies were developed in time and display objects called “preparations” or “preserved specimens” have emerged.

Traditional techniques dating back to the 17th century include injecting waxes, fats, and resins to the vessels, demineralization of bones by dipping them in acid and distending large cavities to eliminate flaccidity with plaster. After these procedures, tissues are fixed in alcohol or oil turpentine inside glass jars and mounted as “wet preparations” or dried and varnished to be preserved as “dry preparations”.²²¹ (Fig. 64-65-66) Preparations captured the momentary appearances of the dissected bodies and enabled their conservation and display in static form for centuries. The display of these wet and dry specimens in the museum, and other spaces in the “system” such as the lecture theatre or the laboratory, was and still is quite important for the anatomy education:

“Preservations, injections, models, dessicated specimens, were all used as objects of study; as a mode of training; as a way of ‘seeing’ systems of barely visible anatomical parts with clarity, away from the messiness of the body; and of maintaining for pedagogy and for research bodies that otherwise too quickly decayed.”²²²

Another category of display objects, anatomical wax models, provide a “lifelike” visual experience of the human anatomy. (Fig. 67) “The anatomical tradition, based on the use of human cadavers, represents the basis of anatomical waxwork modelling.”²²³ In that sense, wax models are considered to be “one-to-one

²²¹ Chaplin, “John Hunter and the ‘Museum Oeconomy’, 1750-1800.” 103

²²² Berkowitz, “Systems of Display: The Making of Anatomical Knowledge in Enlightenment Britain.”10

²²³ Maraldi et al., “Anatomical Waxwork Modeling: The History of the Bologna Anatomy Museum.”5

reproductions rather than representations”²²⁴, even thought to be “more faithful than the real thing.”²²⁵ At this point, the concept of “reality,” or the “reality affect,”²²⁶ comes to the fore since the anatomical displays establish complex relationships with the idea of “real.” The distinction between what is “real” and what is representation might seem quite clear and obvious, nevertheless the line separating the “real” body from the representational body is pretty blurry. For instance, the specimens come from the dissected cadavers, which were once living human beings, nevertheless when they are on display in the museum space they seem like artificial objects, representations of the “real” thing, that is the human body. On the other hand, anatomical wax models which are made up of non-human materials look quite realistic, as if they are actual human bodies. Within this context, Eva Åhrén expresses the complex condition of anatomical objects as follows:

“...the anatomical object is a simulacrum. But, like the relic finger of a saint is a part of the saint’s body (if it’s not a forgery), the body parts in the anatomical museum are actual flesh or bone...while representing a certain anatomical or pathological feature the objects also represent their own realness.”²²⁷

²²⁴ James Elkins, “Cut Flesh,” in *Pictures of the Body: Pain and Metamorphosis* (Redwood City: Stanford University Press, 1999).132

²²⁵ Lucia Dacome, “Waxworks and the Performance of Anatomy in Mid-18th-Century Italy,” *Endeavour* 30, no. 1 (2006): 29–35. 29

²²⁶ Referred to the concept of. “reality effect” defined in Roland Barthes, *The Rustle of Language* (California: University of California Press, 1986).

²²⁷ Åhrén and Sappol, “The Strange Space of the Body: Two Dialogues.” 92

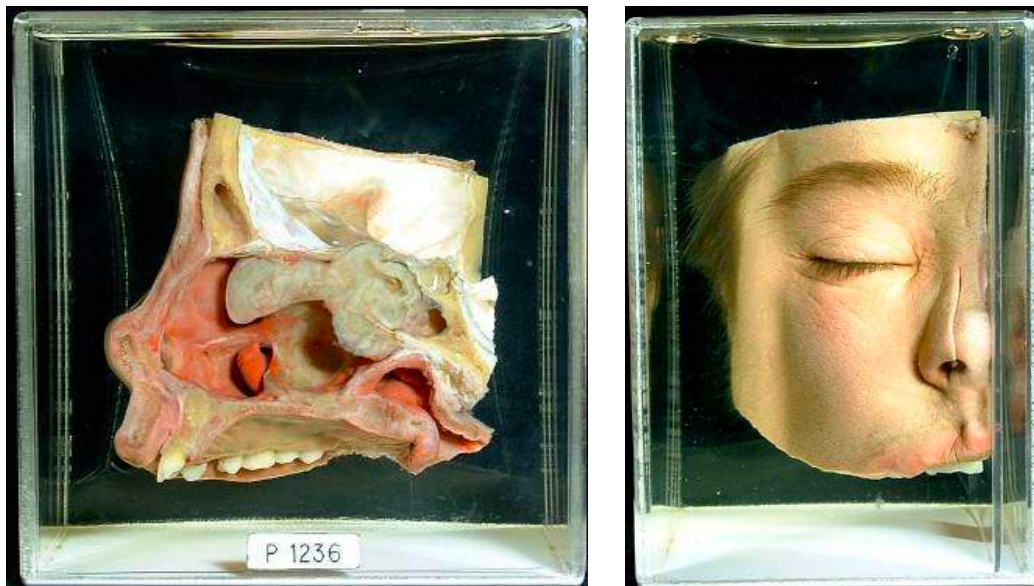

Figure 64. Wet preparation of the vertical section of a boy's face, made by or for John Hunter, before 1793
 Source: Simon Chaplin, "John Hunter and the 'Museum Oeconomy', 1750-1800" (PhD Thesis, King's College London, 2009).125



Figure 65. Dry preparation of human head and neck, 1850-1900

Source: Eva Åhrén, "Making Space for Specimens: The Museums of the Karolinska Institute, Stockholm," in *Medical Museums: Past, Present, Future* (London: The Royal College of Surgeons of England, 2013), 102–15. 114

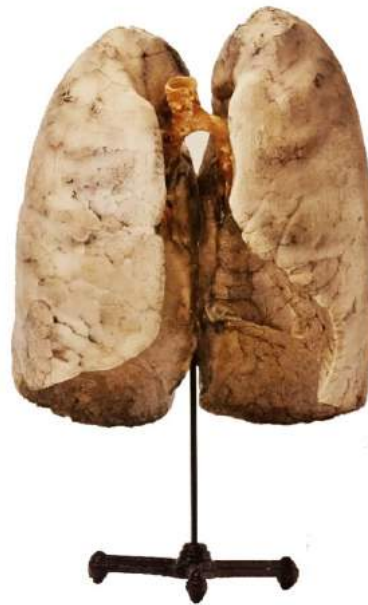

Figure 66. Dry preparation of a lung, 19th century, from Berlin Museum of Medical History collection

Source: Thomas Schnalke and Isabel Atzl, eds. *Dem Leben auf der Spur: im Berliner Medizinhistorischen Museum der Charité*. Prestel, 2010. 52

When the anatomical wax modelling techniques are examined, it is seen that the relationship between “real” and representation is much more complicated. The Bolognese school technique developed by Ercole Lelli (1702-1766) was based on “assembling the waxworks of the muscles onto the bones of human skeletons”.²²⁸ In addition, beard and hair made of actual hair were fixed on the wax models to enhance their realistic look. In another technique used by the school of Clemente Susini (1754-1814) in Florence, wax organs were achieved through the plaster molds taken from the cadavers and then mounted onto the skeleton.²²⁹ The method of Lelli was important in terms of combining the osteological specimen with the wax in order to create a real-like representation of the human body but the technique used by Susini was even more impressive since it captured the reality of the cadaver in terms of copying its exact form.

“Plaster and wax casts of faces, bodies and organs are different: their realness derives from retaining the original form of the body they were cast from... The reality effect of sculpted models of wax, on the other hand, stems from the medium’s capacity to mimic the colour, texture and form of human skin and flesh – they can be uncannily lifelike.”²³⁰

The production of wax, lead or plaster casts from bodies, body parts or bones was highly supported by William Hunter. In principle, for him preparations had the primary role in anatomical teaching and he was against wax models as he found them “tawdry” and “incorrect.” Nevertheless, he favored casts since they possessed greater legitimacy than other models in terms of having “direct physical connection with the body from which it was taken.”²³¹ Regarding the viewpoint of Hunter on the subject, Berkowitz wrote:

“The point of these three-dimensional visual displays was not to act as representations of nature, but to freeze nature herself so that she could be studied. Wax casts were meant to be a ‘perfect likeness’ of the real thing. In

²²⁸ Maraldi et al., “Anatomical Waxwork Modeling: The History of the Bologna Anatomy Museum.”⁷

²²⁹ Maraldi et al. 9

²³⁰ Åhrén and Sappol, “The Strange Space of the Body: Two Dialogues.” 92

²³¹ Chaplin, “John Hunter and the ‘Museum Oeconomy’, 1750-1800.” 129

the continuum of visual displays, they served as an intermediate between nature and representation.”²³²

In that sense, it is possible to say that the method of using casts was the merging of natural with artificial, real with representation, to create a new reality. The recently developed technique of plastination opens up new perspectives in the subject. The technique developed by Gunther von Hagens is simply based on the replacement of all the fats and fluids in the tissues of a cadaver with polymers, resulting in the effective preservation of the colors and structures. (Fig. 68) Although von Hagens describes his technology as “enabling direct inscription, eradicating all mediation between object and representation thus perpetuating the myth of ‘a scientific transparent truth’— a pure representation of the human body without the contamination of human intervention,” José van Dijck notes that the plastinated bodies cannot be considered as real or natural due to their constructed characteristics, such as the replaced body fluids, dyed organs and poses stabilized through metal pins.²³³

These examples of anatomical displays show that in the space of display that is mainly the anatomy museum, the “real” body dissolves into its representations and the representations become “real” bodies.

“So the ‘real’ bodies and body parts... in some sense sculptures in the medium of human flesh and bone. The wax and plaster objects cast from living or dead human beings...are in some sense also ‘real’, a transcription of bodies or body parts. The models (in wax, plaster and other materials), based on observations of patients and specimens, photographs, drawings, memories, and the modeler’s imagination, make no claims to being ‘real’ body parts. But all of the objects, whether ‘real’ or not, involve imagination and technical skill, and draw on conventions of presentation.”²³⁴

²³² Berkowitz, “Systems of Display: The Making of Anatomical Knowledge in Enlightenment Britain.” 370

²³³ José Van Dijck, “Bodyworlds: The Art of Plastinated Cadavers,” *Configurations* 9, no. 1 (2001): 99–126. quoted in Elizabeth Stephens, “Inventing the Bodily Interior: Écorché Figures in Early Modern Anatomy and von Hagens’ Body Worlds,” *Social Semiotics* 17, no. 3 (2007): 313–26, <http://dx.doi.org/10.1080/10350330701448611>. 316

²³⁴ Åhrén and Sappol, “The Strange Space of the Body: Two Dialogues.” 92



Figure 67. Life-size wax model of female anatomy from the workshop of Francesco Calenzoli at La Specola in Florence

Source: Eva Åhrén, "Making Space for Specimens: The Museums of the Karolinska Institute, Stockholm," in *Medical Museums: Past, Present, Future* (London: The Royal College of Surgeons of England, 2013), 102–15.
110



Figure 68. Photograph of a plastinated body by Gunther von Hagens, from the Body Worlds exhibition in Cleveland.

Source: “Body Worlds in the Great Lake Science Center Cleveland,” accessed July 8, 2020, <https://bodyworlds.com/city/cleveland/>.

2.3.5. The Experience of Embodiment

“Our attention is continually directed toward our bodies, and we attend. We are glutted with body images, services, technologies, sensations. Yet we also feel disembodied. We spend much of our lives sitting in cars, or in front of computers and television screens, doing almost nothing with our bodies.”²³⁵

Despite the increasing interest towards the human body in many aspects, people seem to be detached from their own bodies. The connection between the self and the body appears to be lost or weakened.

²³⁵ Sappol, *Dream Anatomy*. 68

“And we need something strong to reconnect ourselves to our bodies, to make contact with life and with death. An aura of realness—the real body, real anatomies, the real self—emanates from the art of Du Tiel, Purcell, Henne, Hirst and Quinn, and the displays of the Mütter Museum, Hunterian Museum, National Museum of Health and Medicine, and Body Worlds. Art is good for you, science is good for you—so we are supplied with moral justification—but what brings the customers through the turn-stile is the pleasure of looking at real bodies and body parts, even two-dimensional visual representations based on “the real body.”²³⁶

As Sappol suggests, anatomical displays or the artworks containing or representing “real bodies,” bodies in flesh and blood, provide a special opportunity to people to reconnect with their own bodies. The power of displaying the body as an anatomical object with its disturbing yet intriguing reality, enable people to see, understand and then, embrace their (im)perfect physical being. Anatomical displays suggest a reconciliation, a deep binding of the self with the body. In anatomy museum the surfaces and the interiors of the body are displayed in a novel way, cut up and divided in pieces, revealing the truth of being a human. It may intimidate and estrange people from their bodies, but also makes them more conscious of their “corporeal, spatial self.”²³⁷

In a broader context, museum objects are considered to be the embodiments of knowledge. In the museum space knowledge is embodied through the objects on display. The display culture dating back to the Memory Theatre of Camillo, relating the objects to knowledge and intensifying the link between “seeing and knowing” sustains its validity today and museums are the most evident cases exemplifying this condition.

In fact, the verb “embody” is quite rich in meanings. The first meaning of the word is to give a concrete form, a “body” to something, to incarnate, to make corporeal. In broader and more abstract context, the verb connotes the act of making something concrete and perceptible. Another significance of the word is to cause something to

²³⁶ Sappol. 70

²³⁷ Sappol. 91

become a body or part of a body, to incorporate.²³⁸ All these descriptions reveal the strong connection between “embodiment” and the “body”. In line with this, the word “corporeal”, referring to the material or the physical being of an object, comes from the Latin word *corpor-* (stem of *corpus*) which means body.²³⁹ Although the term “body” used in these descriptions refers to a physical entity in an abstract sense - not directly indicating the human body – the concepts of embodiment and corporeality cannot be thought independently from the anatomical body. As the etymology and the current use of these words put forward, throughout the history, the body has been the symbol of the physical world. The earthly character has always been represented with the body.

“... the problem of human existence is seen as a drama played out on a cosmic stage, and the vision of human existence is, more often than not, identified with the human body, where there is a close affinity between human, corporeal, and sensible realities. Under these conditions the human body becomes a manifestation or exemplum of reality as a whole, encapsulated in the Middle Ages in the formula *mundus minor exemplum est—maiores mundi ordine.*”²⁴⁰

In this regard, the concept of “embodiment” gains a special status within the context of anatomy museum. In anatomy museum, what is embodied becomes the body itself. The objects on display in the anatomy museum such as the illustrations, films, photographs, models, diagrams and specimens, embody the knowledge of the body.

It is important to underline the fact that, the embodiment that takes place in the museum is not just a theoretical phenomenon. The concept called “embodied experience”²⁴¹ occurs in the museum space. Visiting a museum provides a totally different experience compared to other activities having both didactic and

²³⁸ “Embodiment,” in *Merriam-Webster Dictionary*, accessed July 8, 2020, <https://www.merriam-webster.com/dictionary/embodiment>.

²³⁹ Charlton T. Lewis and Charles Short, *A Latin Dictionary* (Oxford: Clarendon Press, 1879).

²⁴⁰ Dalibor Vesely, “The Architectonics of Embodiment,” in *Body and Building: Essays on the Changing Relation of Body and Architecture*, ed. George Dodds and Robert Tavernor (Cambridge: The MIT Press, 2002), 28–43. 31

²⁴¹ Suzanne Macleod, Laura Hourston Hanks, and Jonathan Hale, eds., *Museum Making: Narratives, Architectures, Exhibitions* (New York: Routledge, 2012). xxi

entertaining character such as reading a book, watching a film or a performance. Museum visit is a full-body experience requiring the active participation of different parts of the body, not just the eye and the ear. Contrary to the viewer of literary material and the audience of cinema or theatre, the museum visitor is mobile.

“Whereas storytelling in literature is determined and confined by the linear arrangement of text on a page; in cinema to visual images on a screen; and in traditional theatre to the static audience with its singular perspective, the museum represents a fully embodied experience of objects and media in three dimensional space, unfolding in a potentially free-flowing temporal sequence.”²⁴²

The embodied experience in anatomy museum suggests different and more intense meanings compared to the embodied experiences in other museums. Being bodily present in a space and experiencing the display objects representing the body disposed in in three dimensions is a unique experience. Seeing an anatomical illustration in a book versus experiencing it in the museum space, together with other anatomical objects produced in manifold media, are fundamentally distinct activities offering different intellectual outcomes. In anatomy museum, the confrontation of the living bodies with the representational bodies in a spatial setting creates a stimulating, challenging and inspiring circumstance. Eva Åhrén describes this condition as follows:

“Being there, immersed, seeing it for real, surpasses the simulacrum of the printed image. Spatiality itself creates a striking difference between experiencing the museum with its specimens and models, and any type of two-dimensional anatomical image. Walking among three-dimensional displays of bodily objects is a more intense experience of embodiment than viewing an image of human anatomy on the page of a book. As a visitor to the museum I cannot avoid establishing multilayered (spatial, physical, emotional, referential, indexical) relations to the objects.”²⁴³

²⁴² Macleod, Hanks, and Hale. xxi

²⁴³ Åhrén and Sappol, “The Strange Space of the Body: Two Dialogues.” 91

As Bell asserted centuries ago, a seminal relationship with the body could not be established by mere observation, the participation of the hand, the coordination between the hand and the eye is essential. This means that the body cannot be understood profoundly without an augmented embodiment. An embodied experience that involves multiple senses is the key to explore and comprehend the body. In the first half of the 20th century, in addition to the embodied experience provided by the traditional exhibition setting, the possibilities of more intensive ways of bodily engagement with the display objects, going beyond observing and walking around, began to be explored.

In 1935, an exhibition that took place in Chicago and then purchased by the Buffalo Museum of Science included interactive displays, transparent models, lighting effects and mechanical apparatuses, “every important organ in the human machine is brought to light for visual instruction of the onlookers”.²⁴⁴ In the report published in the American journal *Popular Science Monthly* entitled as *Wonders of the Human Body reproduced in Museum by Machines and Electricity* the exhibition was described as follows:

“Press a button. A motor whirs; a skull nods; a wrist bone turns on a joint; a bony forearm flexes and beckons. A human skeleton bids you come up close and scrutinize the machine that is man. Press another button. A tiny bright light leaves the left half of a mechanical human body, enters the right half of the heart, and goes out. [...] At one end of the hall, in a darkened circular alcove, atop a black pedestal, stands a complete human skeleton wrapped in transparent material. A light flashes on, and the brain is illuminated. Another light flashes; the heart glows.”²⁴⁵

As expressed in the report, the human body represented like a machine enabled the interactive engagement of the visitors. Through the interactive displays they became an active part of the learning process and the idea of “embodiment” was brought to another level. The concept of interactive displays is a trending issue in museum

²⁴⁴ Canadelli, “‘Scientific Peep Show’: The Human Body in Contemporary Science Museums.” 172

²⁴⁵ “Wonders of the Human Body Reproduced in Museum by Machines and Electricity,” *Popular Science Monthly* 127 (1935): 36–37. 36 quoted in Canadelli, “‘Scientific Peep Show’: The Human Body in Contemporary Science Museums.” 172

studies and with the progressing technologies and visualization methods, these displays are further developed. Tactile models, interactive projections and installations focusing on different aspects of the human body promote an advanced bodily involvement. The opportunity to interact with the exhibits is “a grateful relief to the sightseer who has walked miles of musty galleries dotted with “don’t touch” signs.”²⁴⁶

The installation of Jussi Ängeslevä, exhibited in 2001, named as “Body Scanner” is a recent example epitomizing the concept of interactive anatomical displays. (Fig.69) The installation, that uses the dataset from the National Library of Medicine’s Visible Human project, allows the visitors to track the body segments shown on the screen against theirs, creating the illusion of seeing their own bodies from an anatomical perspective.²⁴⁷



Figure 69. Body Scanner Interactive installation, by Jussi Ängeslevä, 2001.

Source: Michael Sappol, *Dream Anatomy* (Bethesda MD and Washington DC: US Dept. of Health and Human Services, National Institutes of Health, National Library of Medicine, 2006). 159

²⁴⁶ Harry Edwin Kleinschmidt, “New Germany Teaches Her People. An Account of the Health Exposition of Berlin,” *American Journal of Public Health and the Nation’s Health* 25, no. 10 (1935): 1108–13. 1111–1112. quoted in Canadelli, ““Scientific Peep Show’: The Human Body in Contemporary Science Museums.” 172

²⁴⁷ Sappol, *Dream Anatomy*. 159

CHAPTER 3

ANOTHER DISPLAY ENVIRONMENT: THE ANATOMICAL THEATRE

3.1. Memory and Theatre

3.1.1. Representational Systems

As elaborately explained in the previous chapter, it is argued that the multiplicity and the complexity of the activities shaping the anatomical education have led to the re-definition of a priori functions of the educational spaces. An important outcome of this re-definition process was the transformation of the spaces that have been identified with other functions, into display environments.

In addition to the spaces discussed within the context of the Anatomical Department of Marischal College, anatomical theatres, large spaces in theatre form designed for anatomical dissections, had been prominent spaces of anatomical education for centuries. Anatomical theatre, emerged as a distinct architectural form in the late 16th century, was not only associated with the anatomical scholarship but also the social, cultural, ideological, and intellectual structures of the society. Apart from its sophisticated relations to these different spheres, it was also connected to the notion of museum in many respects. Anatomical theatre and museum share historical, functional, conceptual and spatial grounds. In this context, the idea of “display” shines out as a key concept that shaped both spaces by theoretical and physical means. Therefore, the acknowledgement of the anatomical theatre as a display space suggests a seminal re-reading of both theatre and display space.

Understanding the architecture of the structures built for scholarship, begins with understanding the complex relationship between “space” and “knowledge”.

Consequently, it becomes essential to examine the spatial orders established with reference to the practices of production, collection, and storage of knowledge. New forms and types of architecture emerge and develop in line with the continuously transforming and updating knowledge activities. In broader terms, architecture have always been in a symbiotic relationship with knowledge structures. Cognitive processes are guided, shaped or altered by architectural thinking and practice while guiding, shaping or altering it reciprocally.

Within this framework, the emergence and development process of the anatomical theatre and its architecture are examined together with its value and role as a display space, considering the social, cultural, intellectual context. At this point, it is necessary to begin by exploring the intellectual environment set by the ideas, ideals and ways of thinking of Renaissance Europe.

Towards the end of the sixteenth century, collections and early museums had become prevalent. These collections or museums were not established for educational or scholarship purposes, instead primary motivation behind this collecting culture was to represent “an entire or a partial world picture”²⁴⁸. Since representation was the key concept shaping these spaces, Eilean Hooper-Greenhill refers to them as “representational systems”²⁴⁹. The “cabinet” is considered as the archetype of these representational systems. To better understand the concept of cabinet, it is necessary to look into the etymological development of the word. The term “cabinet” is a diminutive form of “cabin”, meaning a hut or cottage which appears in French as well as in early English as *cabane*.²⁵⁰ From 16th century onwards, the term “cabinet” has been used corresponding to a case or cupboard with shelves or drawers for storing or displaying articles²⁵¹. The cabinets where natural and artificial curiosities were stored and displayed in a peculiar manner were specifically called as “cabinets of curiosities”. These collections of rare objects were named after the furniture that

²⁴⁸ Hooper-Greenhill, *Museums and the Shaping of Knowledge*. 78

²⁴⁹ Hooper-Greenhill. 78

²⁵⁰ Paul Haupt, “The Etymology of Cabinet,” *Journal of the American Oriental Society* 28 (1907): 108–11, <https://www.jstor.org/stable/592762>. 108

²⁵¹ Hooper-Greenhill, *Museums and the Shaping of Knowledge*. 86

they were housed in. In late 16th - early 17th century, the word began to be used to describe the “closet beyond principal bedchamber where the owner’s collection of curiosities, pictures and other small works of art could be displayed for the delectation of close friends and important guest”²⁵² or more generically the small room providing seclusion like a secret storehouse or treasure chamber. In documents from 18th century, the word “cabinet” was used “to refer both to the cupboards or containers of the collections, including the room spaces, and to the entire collection”, thus in some sources discussing the collections of that period the terms “collection” and “cabinet” were used interchangeably²⁵³. Today, the word is used to denote a piece of furniture and a collection of objects of natural specimens, art, antiquities, etc. Although not very common, “small room” or “small exhibition room in a museum” are among the currently used meanings of the word.²⁵⁴ Considering the etymological progress of the word and the meanings it gained throughout the history, the concept of “cabinet” becomes more loaded. Just the word “cabinet” itself refers to a collection of objects, a furniture housing a collection and a room including various furniture filled with collections of objects, at the same time. The term, by both, denoting the physical case/space of the collection and also having various spatial connotations coming from its etymology underlines the significant role of the display space for the collections.

“[T]he cabinets were constituted with the aim of representing a picture of the world”²⁵⁵ as they were the primary examples of the collections and the early museums established in 16th century with this intention. Within this context, the

²⁵² C.R. Hill, “The Cabinet of Bonnier de La Mosson (1702–1744),” *Annals of Science* 43, no. 2 (1986): 147–74, <https://doi.org/10.1080/00033798600200191>. quoted in Eileen Hooper-Greenhill, *Museums and the Shaping of Knowledge*. Routledge, 1992.88

²⁵³ Hooper-Greenhill, *Museums and the Shaping of Knowledge*. 88

²⁵⁴ Haupt, “The Etymology of Cabinet.” 108

²⁵⁵ Hooper-Greenhill, *Museums and the Shaping of Knowledge*.80

cabinet was associated with the concept of *theatrum mundi*²⁵⁶ and referred to as the “cabinet of the world”.

At this point, it is important to mention Heidegger’s notion of *Weltanschauung*, translated as “world view”²⁵⁷. He makes a clear distinction between the Middle Ages and modern times in terms of the perception and presentation of the world. Being in Middle Ages meant belonging to a definite level in the order of created things. The world was not open to knowledge, skills and control. It was not yet objectified, therefore not yet conveyed as a representation. Conversely, in modern times the identity of the world is pursued and found in representations, which present the world as something that can thoroughly be known, managed, altered and evaluated. In better terms, Heidegger argues that the distinctive feature of modern times is the world becoming a view.²⁵⁸

The cabinet was one of the earliest and most extensive attempts in the constitution of the “world as a view”. Considering the time period when the cabinet emerged and developed, it was a reflection of the end of the sixteenth and the beginning of the seventeenth century which means that it was between medieval and modern, pre-modern. The idea of creating a “picture of the world” was realized through the “cabinets of the world.”^{259 260}

²⁵⁶ *Theatrum mundi* translated as the “Greater Theater of the World” is a metaphorical concept developed in Western philosophy and literature, visible in significant theories and works such as Plato’s allegory of the cave and Shakespeare’s play *As You Like It*. According to this concept, the world is portrayed as a theater where people are the characters, the Creator-God is the author and the actions of the people under God’s sovereignty create the drama.

²⁵⁷ Martin Heidegger, “The Age of the World View,” *Boundary 2* 4, no. 2 (2019): 340–55, <https://www.jstor.org/stable/302139>.

²⁵⁸ Heidegger.

²⁵⁹ Hooper-Greenhill, *Museums and the Shaping of Knowledge*. 84

²⁶⁰ During the sixteenth and seventeenth centuries various “cabinets of the world” were built all around the Europe. The variety was caused by three major elements that were epistemological, organizational and programmatical. The character of the cabinets were shaped by their owner/collector. The title, powers and the world view of the owner were very influential in determining the identity of the cabinet. A “cabinet of the world” established by a prince at the center of the political arena was very different from the one constituted by an Hermetic merchant at the center of trading network. (Hooper-Greenhill. 102)

Regarding all these factors, cabinets were housed by manifold spaces, varying in size and design. A cupboard, a room or an entire building could be chosen as a space for placing the collections. In addition to the spatial variety, in every cabinet, the collection objects were different and the arrangements of the objects in the selected spaces were following diverse organizing principles. While the cabinets in the north of the Alps in Germany, Bavaria and Austria were named as “*Kunstkammern*” or “*Kunstschränke*”, in Italy terms such as “studio”, “*studiolo*”, “*guardaroba*”, “*museo*” and “*galleria*” were used to describe the cabinets. In the Schloss Ambras of Innsbruck different rooms were called “*Kunstkammer*”, “*Turkenkammer*”, “*Antiquarium*”, “*Heldenrust-kammer*” indicating the various contents of the rooms. “*Schatzkammer*” is commonly found as is “*Anatomie-kammer*”.²⁶¹

All these “cabinets of the world” were constituted by the principles of the Renaissance *episteme*.²⁶² According to the description made by Foucault, Renaissance *episteme* is characterized by relations of resemblance. He states that:

“Up to the end of the sixteenth century, resemblance played a constructive role in the knowledge of Western culture. It was resemblance that largely guided exegesis and the interpretation of texts; it was resemblance that organized the play of symbols, made possible knowledge of things visible and invisible, and controlled the art of representing them.”²⁶³

Considering Foucault’s argument, it is possible to say that Renaissance *episteme* refers to the case that knowledge being understood as a matter of resemblance between things. In Renaissance production and communication of knowledge was based on resemblance. In better terms, knowing in Renaissance depended on knowing the system of resemblances and knowledge could only be achieved by reading signs which were themselves a system of resemblances. Regarding the consequences of resemblance being the agent shaping knowledge Foucault says that:

²⁶¹ Hooper-Greenhill.89

²⁶² Hooper-Greenhill. 84

²⁶³ Michel Foucault, *The Order of Things: An Archeology of the Human Sciences* (London: Routledge, 2005). 19

“By positing resemblance as the link between signs and what they indicate, sixteenth-century knowledge condemned itself to never knowing anything but the same thing, and to knowing that thing only at the unattainable end of an endless journey.”²⁶⁴

Within this context, the pursuit of knowledge was an inconclusive and undetermined process since it was guided by resemblance. The attained knowledge had no rational grounds and destined to be incomprehensible and confused. Foucault describes the sixteenth-century learning as “an unstable mixture of rational knowledge, notions derived from magical practices, and a whole cultural heritage whose power and authority had been vastly increased by the rediscovery of Greek and Roman authors.”²⁶⁵ The “cabinet of the world” appeared in sixteenth century was a product of this intellectual environment where truth is not differed from falsehood. The irrational basis of the mentality of the era was reflected on the composition of the cabinets. Therefore, the knowledge shaped through these cabinets and their intellectual contribution are considered to be vague or inaccurate. Although the correlation between the cabinets and knowledge seems blurry and ill-defined, their representational function was quite direct and legible.

Since the main intention behind “the cabinet of the world” was to present a picture of the world, the organization of the cabinet was designed to reflect the order of the world as it was portrayed in late Renaissance. According to the cosmological understanding dominating the social, cultural and scientific practices in 16th century, the world was divided into the macrocosm, referring to the universe, and the microcosm, referring to the human-being. The paired concept of macrocosm and microcosm puts forward the thought that there is a certain similarity based connection/relation between the universe and the human-being. In fact, the concept

²⁶⁴ Foucault.34

²⁶⁵ Foucault.35

of macrocosm and microcosm is a deep-rooted philosophical tradition dating back to ancient Greece.²⁶⁶

In the late Renaissance, macrocosm represented the Creator-God and “nature” as their product and microcosm represented human-being and “art” as their product. The world of nature and the world of art were seen to be in constant engagement, either as rivals or companions. The distinction between art and nature created two major classes for the categorization of things. The two categories were named as *naturalia* and *artificialia*, referring to God and human, macrocosm and microcosm respectively.²⁶⁷ Within this context, the concept of cosmos coming from the Greek term *kosmos* meaning ‘order, orderly arrangement’ referred to the view of the entire universe as a well-ordered whole. Cosmos being the antithetical of the concept of chaos involved all the interactions between macrocosm and microcosm and indicated the harmony and balance between them. In point of fact, the relation between macrocosm and microcosm was beyond constituting a harmonious unity. It was considered that human was a representation of the universe and the universe was an anthropomorphic entity. According to the late Renaissance mindset, the order of the world was shaped around this reciprocal resemblance-based condition between the human and the universe.

²⁶⁶ Although not using the exact terminology of microcosm-macrocosm, Pythagoras presented the idea of a correspondence between the universe and human-being by saying that they form a harmonious unity together. A century later, the concept introduced by Pythagoras was elaborated by Plato and brought into an advance form by Leonardo da Vinci in Renaissance. After the 17th century through the development of modern science, the macrocosm-microcosm duality lost its effectiveness, however it is still referred to in modern sociological and philosophical theories and continue to be the essence of many religious beliefs and practices.

²⁶⁷ Hooper-Greenhill, *Museums and the Shaping of Knowledge*.90

3.1.2. The Art of Memory

The alliance between knowledge and memory dates back to ancient Greece. In a society where there was a goddess attributed to memory, the emergence of a mnemotechnic method consisting of various principles and techniques to train and improve the memory referred to as “the art of the memory”, *ars memoriae*, was no coincidence.²⁶⁸

According to a legend passed on by Cicero at a banquet given by a nobleman in Thessaly the poet Simonides presented a lyric poem in honor of the host. Shortly after his performance Simonides was called outside. During his absence, all of a sudden, the roof of the hall where banquet took place collapsed and all the diners including the host were crushed to death. The corpses under the ruins were so disfigured that the relatives who came to take them away for burial could not recognize them. But Simonides found he was able to identify the dead bodies by remembering the places at which they had been sitting at the table.²⁶⁹

“He [Simonides] inferred that persons desiring to train this faculty (of memory) must select places and form mental images of the things they wish to remember and store those images in the places, so that the order of the places will preserve the order of the things, and the images of the things will denote the things themselves, and we shall employ the places and images respectively as a wax writing-tablet and the letters written on it.”²⁷⁰

²⁶⁸ In Greek mythology, Mnemosyne, who was the daughter of Uranus (Heaven) and Gaea (Earth), was believed to be the goddess of memory having the power to control all the memory of the universe. (Hesiod, *Theogony Works and Days Testimonia*, ed. Glenn W. Most, *Harvard University Press* (London: Harvard University Press, 2006). 15) Her role was quite important since before the development of the written language, remembrance was the foundation of the society and civilization. The major impact of the oral culture was the reliance on memory for all the social, political and cultural activities. Remembrance was the only way of storing and communicating knowledge. Without the memory it would be impossible to recall past conversations, make agreements, set rules and keep track of the activities and occurrences. The name Mnemosyne shares the same root as the word mnemonic, which refers to methodologies or systems assisting remembering. Both come from the Greek word *mnēmē* having the meaning of “remembrance, memory” and coming from the root *men-* signifying the verb “to think”.

²⁶⁹ Frances Amelia Yates, *The Art of the Memory* (New York: Routledge, 1966). 2

²⁷⁰ Cicero, *De oratore*, II, lxxxvi, 351-4. quoted in Yates. 2

In the story what made possible the identification of the mangled corpses after the accident was the visual memory image of the orderly arrangement of the diners around the table, linking them with their places. Considering the comment of Cicero given above, image, place and order were the important elements for remembrance that constitute the basis for the art of memory. Therefore, it is considered that this anecdote represents the birth of the “art of memory” as an essential skill that have shaped the knowledge in Western societies for centuries.

The primary field of use of the art of memory was rhetoric. It was employed as a technique by which the orators could enhance their memory which would enable them to deliver long and complex speeches from memory without any errors or inaccuracies. The mnemonic of places (*loci*) and images (*imagines*) formed the basic structure. A *locus* was a place easily grasped by the memory like a house, an intercolumnar space, an arch. *Imagines* were forms, marks or simulacra of that which was to be memorized. There were general principles to be followed and the first step was to imprint on the memory a series of places (*loci*). Despite the use of other types, the most common type of mnemonic place system was the architectural type which is also referred to as the “method of *loci*”. Because of its common use the architectural mnemonic is often characterized as the art of memory itself.²⁷¹ In order to create a series of places in memory, the building to be remembered should be selected as spacious and varied as possible and all the spaces should be imagined in detail including the statues and other decoration elements.

The formation of *loci* was the most critical task for the art of memory since the same set of *loci* could be used repeatedly for remembering various material. Therefore, there were certain recommendations to be followed while choosing the *loci*:²⁷²

- To correctly remember the order of the *loci* it is advised to mark each fifth locus with a symbol or assign a distinguishing virtue.
- It is better to form the *loci* of the memory in a deserted and isolated place to prevent the distraction which might be caused by crowds of passing people.

²⁷¹ The method is described in detail in *Institutio Oratoria*, a twelve volume textbook on the theory and practice of rhetoric written by Roman rhetorician Quintilian and published in 1549.

²⁷² (Yates, *The Art of the Memory*. 7-8)

Therefore, the selection of an unfrequented building for memorization is highly suggested.

- Memory *loci* should not be too much like one another. For instance, too many intercolumnar spaces are not good, since their resemblance to one another might be confusing.
- Memory *loci* should not be too large or too small since in too big *loci* the mentally placed images will seem vague and in too small ones the images will be overcrowded.
- The *loci* should not be neither too brightly illuminated nor too dark since the images may glitter and dazzle in too bright places and in dark places the shadows may conceal the images.
- The intervals between the *loci* should be of moderate extent, maybe about thirty feet, “for like the external eye, so the inner eye of thought is less powerful when you have moved the object of sight too near or too far away.

It is important to underline that “fictitious places” instead of “real places” could be used since the mind is capable of creating imaginative settings to be used as *loci*.

After completing the first step of imprinting the *loci* on the memory, the images by which the speech is to be remembered are placed in the spaces of the building which have been previously memorized. The images should be the representatives of the themes and concepts constituting the speech. After the memorization of the building and the assignment of the images to the spaces of the building, the speech becomes committed to the memory and ready to be delivered. During the speech, the orator visits all the spaces in turn and attains the images from the places that they have been embedded. This method ensures the remembrance of the points of the speech in the right order, since the order is fixed by the memorized sequence of the spaces of the building.²⁷³

As an example, the figures below illustrate “Abbey memory system” developed by Johann Horst von Romberch in his book *Congestorium artificiosae memoriae* (1533). In the figure on the left an abbey with its associated buildings are illustrated. The images representing various themes to be memorized are shown in the spaces such as the courtyard, library and chapel of the abbey. The illustration on the right is like

²⁷³ Yates. 3

space, depth and lighting are mentioned and their ideal conditions for better memorization are specifically described. In addition, Yates argues that “an art which uses contemporary architecture for its memory places and contemporary imagery for its images will have its classical, Gothic, and Renaissance periods, like the other arts”.²⁷⁶ Since the main source of the memory *loci* is the surrounding built environment, the architectural style of the time reflects on the places imprinted as a part of the process of the art of memory. In that sense, as the architecture evolved the *loci*, thus the art itself had evolved.

At this point, it becomes necessary to mention the significant role of sight for the art of memory. In *De Oratore* upon the legend of Simonides Cicero says that the emergence of the art of the memory rested not only on the discovery of the importance of order for memory, but also the realization of the power of the sense of sight. Further on this subject he writes:

“...that the most complete pictures are formed in our minds of the things that have been conveyed to them and imprinted on them by the senses but the keenest of all our senses is the sense of sight, and that consequently perceptions received by the ears or by reflexion can be most easily retained if they are also conveyed to our minds by the mediation of the eyes.”²⁷⁷

When the complicated process of the art of memory is unfolded, it becomes evident that it is a “seeing” based practice. The initial step is the memorization of a place and it is essentially based on past visual experience. A place which has been seen before such as a building, field or a garden, in most cases a building, provide the source material for the creation of the memory *loci*. When the memory is needed, the previously memorized spaces with embedded objects representing the speech points are recalled in a certain order. In other words, a former visual experience imprinted on the memory is mentally re-seen.

²⁷⁶ Yates. xi

²⁷⁷ Yates.4

The notion of visual mental imagery constitutes an important part of the method of loci. Visual mental imagery also referred to as “visualizing”, “seeing in the mind’s eye”, “having a picture in one’s head”, “picturing”, or “having/seeing a mental image/picture” is a quasi-perceptual experience as it resembles perceptual experience but occurs in the absence of the appropriate external stimuli. It is generally understood to bear intentionality, thus function as a form of mental representation²⁷⁸. Imagery experiences are mostly the echoes, copies or reconstructions of actual perceptual experiences from the past.

Within this context, Yates mentions a concept called “inner vision” which he considers essential to be able to practice the art of memory²⁷⁹. Hooper-Greenhill names it as “inner gaze” and describes its role as:

“In the absence of paper, and with no resources for discourse other than speech aided crucially by memory, an inner gaze with a selecting, ordering, synthesizing, and recall function was developed, a gaze that ‘worked’ through an intimate knowledge of architecture and artefacts, places and objects.”²⁸⁰

The vision/gaze referred to here, corresponds to a perception beyond the sense of sight. It is based on the act of “seeing” but involves other analytical actions such as selecting, ordering and synthesizing. It also plays a critical role in remembrance by enabling the previously seen objects to be re-seen in mind, when needed. More importantly, it is a gaze which operates spatially. Its main focus is the surrounding built environment and it has the power to perceive and elaborately register the architectural elements and their spatial qualities, then associate them with different objects or elements. In better terms, inner vision/gaze presents an advance form of seeing. It is an analytical “way of seeing”²⁸¹ engaged with space-related knowledge.

²⁷⁸ Thomas, “Mental Imagery.”

²⁷⁹ Yates, *The Art of the Memory*.4

²⁸⁰ Hooper-Greenhill, *Museums and the Shaping of Knowledge*.92

²⁸¹ John Berger, *Ways of Seeing* (London: Penguin Books, 2008).

The description of this inner vision/gaze also coincides with the modern concept of “spatial ability”. Spatial ability or visuo-spatial ability is the capacity to understand, reason, and remember the spatial relations among objects or space.²⁸² This ability requires spatial perception which is about comprehending spatial relationships with respect to the orientation of one’s body. It consists of being able to visually understand external spatial information such as size, distance, color, light, form and position.²⁸³ The information mentioned here corresponds to the spatial properties mentioned in the principles listed for the selection and memorization process of the *loci*.

The art of memory, specifically the method of *loci*, emerged in Ancient Greece and described in rhetorical treatises such as anonymous *Rhetorica ad Herennium*, *De Oratore* of Cicero and *Institutio Oratoria* of Quintilian had a quite significant impact on the development of the Western intellectual tradition throughout the ancient, medieval and Renaissance periods.

In sixteenth century, due to the progress in science, philosophy, art and culture some scholars took a negative stand against the art of memory. For those scholars, with the advent of the printed book, remembrance, therefore a strong memory and advanced recall skills were no longer needed. For Erasmus and other humanists, the art of memory belonged to medieval times, linked with outdated methods of scholastic thought, and related to mysterious and doubtful knowledge, thus must be eliminated from the intellectual practices. Despite the rigid opposing attitude of some prominent scholars, the art of memory did not fade away, instead, it went through a serious transformation. With its changed nature, it influenced and was influenced by

²⁸² Carol Blackburn, “What Is Spatial Ability?,” *Imagine* 2, no. 4 (2016): 1–5, <http://web.jhu.edu/cty/STBguide.pdf>.

²⁸³ Alison Simmons, “Spatial Perception from a Cartesian Point of View,” *Philosophical Topics* 31, no. 1/2 (2003): 395–423. 395

the intellectual models of the time. It was taken up by the foremost philosophical movement of the Renaissance, the Neo-Platonic movement.^{284 285}

In Renaissance beyond being a method to remember, the art of memory was adapted to become a method for understanding the complex order of the world. Hence, it was employed as a practice for discovering, describing, and synthesizing all the constituents of the world. During the Renaissance, the art of memory was used to recall the entire ordering of the universe. The idea of creating an entire or partial world picture was very much related with the techniques of the art of memory. The images representing the knowledge of the world pierced on the memory places were recalled through a virtual walk through those memorized spaces. This meant that, the art of the memory was practiced “to aid the memory of the known world”.^{286 287}

Within this context, it could be said that the art of memory, in terms of conceiving the human memory as a faculty for organizing and knowledge, was the primary agent that influenced and shaped the intellectual models of the Renaissance. By the mid-eighteenth century, these models had been replaced to a large extent with the ones that were dependent on the external organization of knowledge through books, catalogues and systematic collections instead of the power of memory.²⁸⁸

²⁸⁴ Hooper-Greenhill, *Museums and the Shaping of Knowledge*.97

²⁸⁵ The movement had a hermetic core. The father of Neo-Platonism, Plotinus integrated the concept of microcosm-macrocosm with his mystical metaphysical ideas. He conceived the cosmos and human being as a continuous existence. According to his theory, the spiritual and the material or the soul and the body should be considered as a united entity. The togetherness of the spirituality and materiality applied to all beings and each being manifested these features in different extents. The mindset of Renaissance was highly shaped with Neo-Platonic ideas, therefore it was more mystical compared to medieval times. This thought system affected the older techniques of the art of the memory by attributing occult qualities to them. (Hooper-Greenhill.97)

²⁸⁶ Hooper-Greenhill.96

²⁸⁷ Some memory systems, such as the one developed by the Italian Dominican friar, philosopher, mathematician, poet, cosmological theorist, and Hermetic occultist Giordano Bruno, was intended to fill the mind of the practitioner with images representing the knowledge of the entire world to be used for reaching the intelligible world beyond appearances which was believed to give the power to affect and control the happenings of the real world. These ambitious attempts were serving the ulterior motive of creating sort an “encyclopedia” of knowledge of the world. (Frances Amelia Yates, *Giordano Bruno and the Hermetic Tradition* (Chicago: University of Chicago Press, 1964).

²⁸⁸ Mattias Ekman, “Spatial Orders of Memory and Knowledge: Architectural Schemes for Collections in Seventeenth-Century Sweden,” *Nordisk Museologi* 1 (2016): 148–58. 149

Despite that, the concept of place-based memory was used in different areas and mentioned in the specialized works on psychology, neurobiology, rhetoric and philosophy till the mid nineteenth century. Even today, it is possible to see its influence in different studies carried out in manifold areas. The frequently used phrases in English such as “in the first place”, “in the second place” could be considered as the most observable traces of method of *loci*.²⁸⁹

3.1.3. Memory Theatre

“Camillo’s Theatre represents a new Renaissance plan of the psyche, a new mental map, a change that has happened within memory, and from which outside changes derived their impetus.”²⁹⁰

In sixteenth century under the influence of Neo-Platonic movement, the art of the memory entered upon a new phase. Before then, memory spaces and images had been abstract and existed in imagination. The *loci* and *imagines* defined by Cicero had been mental constructions and continued to be ideational till the 1500s. In sixteenth century they began to appear in the physical world. Memory places and images were not existing in thought anymore, through art and architecture they became real-life objects. The ambitious unfinished project of Giulio Camillo (ca. 1480–1544), The Theatre of Memory, was the most striking case exemplifying the concept of materialization of the places and images serving for the preservation and remembrance of knowledge. It was constructed at the court of Francis I in France to show the sovereignty and the power of the king by representing him “as God on

²⁸⁹ W.H. Burnham, “Memory, Historically and Experimentally Considered. I. An Historical Sketch of the Older Conceptions of Memory,” *The American Journal of Psychology* 2, no. 1 (1888): 39–90, <http://www.jstor.com/stable/1411406>. 85

²⁹⁰ Hooper-Greenhill, *Museums and the Shaping of Knowledge*.101

earth”.²⁹¹ The Memory Theatre designed by Camillo was described in his masterpiece *L'Idea del Teatro* (The Idea of the Theater) which was lost or destroyed shortly after his death.²⁹²

The Theatre was Camillo's self-assigned task to carry the ancient art of memory to a next level by creating a device enabling everybody to speak and write as fluently as the great orators. In that sense, Camillo's theatre was considered to be a mnemotechnic tool, meant to provide speakers systematical material for their thinking.

In fact, Camillo's scheme was beyond of the ancient orators in another aspect. According to Richard Bernheimer, it was focused on the representation and display of universal truth. For this reason, The Theater of Memory must take its place not only in the history of the mnemotechnics or mnemonic arts but also in the history of other disciplines such as philosophy, cosmology and architecture. It is likely that Camillo's way of thinking and his theatre scheme affected these fields of thought greater than known, therefore the ideas created during later Renaissance were mostly elaborations of his.²⁹³ In parallel with Bernheimer, Yates wrote:

“Theatre is based on the principles of the classical art of memory. But his memory building is to represent the order of eternal truth; in it the universe will be remembered through organic association of all its parts with their underlying eternal order.”²⁹⁴

Following the “world view” concept introduced by Heidegger, the Theatre was a vision of the world. Furthermore, it is possible to argue that it was designed to unveil the knowledge of the entire universe. It was a representation of the order of the universe through the recalling of its components and the relations between them. According to Hooper-Greenhill “[i]n a single glance, the memory theatre could

²⁹¹ Richard Bernheimer, “Theatrum Mundi,” *The Art Bulletin* 38, no. 4 (1956): 225–47, <https://www.jstor.org/stable/3047670>. 228

²⁹² Bernheimer. 226

²⁹³ Bernheimer. 225

²⁹⁴ Yates, *The Art of the Memory*. 138

reveal the secret of the universe which could then be apprehended, understood, synthesized, and memorized.”²⁹⁵ Memory theatre acted as a cognitive tool for comprehending the enigmatic knowledge of the universe.

Based on the writings of Gilbert Cousin, a French theologian who had seen the Theatre of Camillo at the court of France, the theatre was a wooden structure adorned with many images and filled with a greater number of boxes and coffers. In addition, there were papers hanging from its walls containing explanatory texts. The Theatre was on an architectural scale, providing enough space to accommodate at least two people.²⁹⁶

The architectural layout of Camillo’s Theatre was in many aspects similar to the Roman theatre described by Vitruvius (46-30 BC) in *De Architectura*,²⁹⁷ and elaborated by Leon Battista Alberti in *De Re Aedificatoria* (1452), the first architectural treatise in Renaissance. According to the details given in the book of Camillo, the Theatre had seven levels accessible through seven sets of doors, similar to the theatre depicted in *De Re Aedificatoria*, which was attributed to the seven times seven words in the Lord’s prayer.²⁹⁸ Camillo himself did not mention the overall form of the Memory Theatre in his book but there are other sources commenting on the form of Camillo’s Theatre. Yates commented on the subject as follows:

“We have heard some of Camillo's contemporaries describe his work as an amphitheatre, but these indications make it quite certain that he was thinking of the Roman theatre as described by Vitruvius. Camillo's Memory Theatre is however a distortion of the plan of the real Vitruvian theatre.”²⁹⁹

²⁹⁵ Hooper-Greenhill, *Museums and the Shaping of Knowledge*.97

²⁹⁶ Bernheimer, “Theatrum Mundi.” 227

²⁹⁷ The Roman and Greek theatre architecture described by Vitruvius is further discussed in Chapter 3.2.3.

²⁹⁸ Bernheimer, “Theatrum Mundi.” 227

²⁹⁹ Yates, *The Art of the Memory*.136

As Bernheimer pointed out, the overall form of the Theatre was probably semicircular rather than amphitheatrical following the Roman theatre tradition portrayed by Vitruvius and Alberti.³⁰⁰

The scheme of Camillo was aiming to display the order of the world as a structured, rational and systematic entity in line with the ideas of the most thinkers of that time. Hence, every half-round row in the Theatre was a simile for a level in the Divine plan. From bottom to top the seven levels were representing the seven planets, the simple elements of matter, the elements in a state of mixture, man's inner beings, the juncture in him of body and soul, the varieties of his work and the arts. Camillo explains that the first causes were placed closest to the stage and the derivations from them higher and higher up. This layout was a replica of the order of Roman theatre described by Vitruvius, where the most respected people were seated closest to the spectacle and those of lesser respectability on upper seats, farther from the scene.³⁰¹

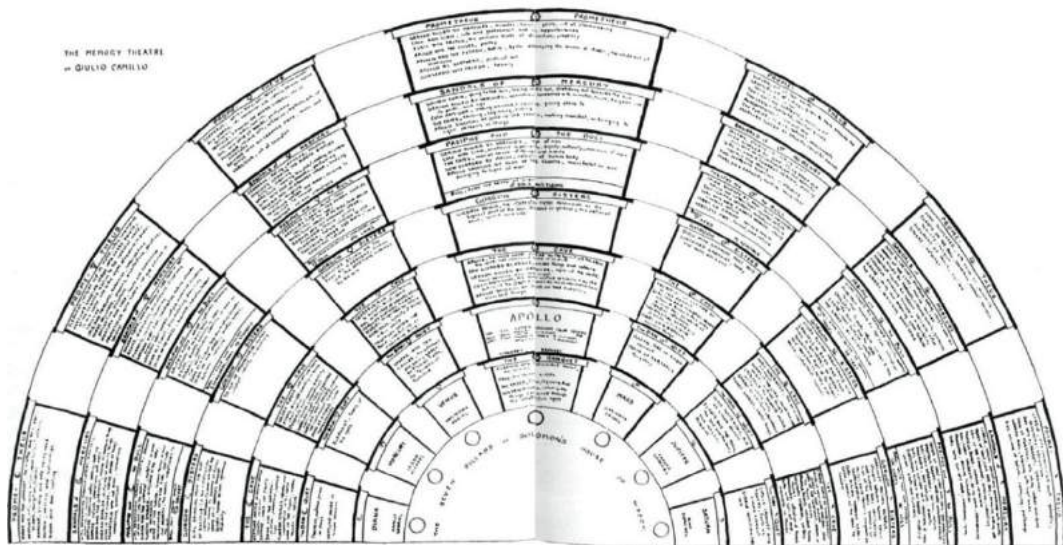

Figure 72. Plan of the Memory Theatre of Giulio Camillo

Source: Frances Amelia Yates, *The Art of the Memory* (New York: Routledge, 1966). 138

³⁰⁰ Bernheimer, "Theatrum Mundi." 227

³⁰¹ Bernheimer. 227

The visualization of this order was achieved through images painted over the entrance doors representing the main concepts. Under those images there were other painted images depicting subsidiary concepts.³⁰² The hierarchy between the images and their correlation with the architectural elements created a consistent, orderly and self-contained whole, like the world itself.

The ancient art of memory was a flexible instrument. The memory places and images were freely chosen by the orators themselves for facilitating any speech. In addition, the spatial variety and distinctness of the chosen places was strongly recommended. Comparing that with Camillo's scheme, it is seen that the Memory Theatre presents a prearranged and inflexible setting. Camillo's aim was to create a single structure that would provide ready-made material sufficient for any speech that anybody would ever want to deliver.³⁰³ Within this context, Camillo's approach may seem too ambitious and unrealistic, assuming that a one-piece physical structure would surpass what mind/imagination could do. But for Camillo and many other thinkers of the time, it was crucial to update the principles of the art of memory to achieve a divine and cosmological layout.

The emotionally striking images of classical memory, transformed into corporeal similitudes by the devout Middle Ages, were transformed again into magically powerful images towards the end of sixteenth century.³⁰⁴ Regarding the condition of the art of memory in Renaissance Hooper-Greenhill writes:

“There is no doubt that the art of memory, with its capacity for both revelation and concealment, was particularly sought by those Renaissance philosophers that were drawn to the occult.”³⁰⁵

In that sense, as a member of Neoplatonic creed, Camillo's theatre had a divine and occult nature. The method of presentation of the Theatre was allegorical, using the

³⁰² Bernheimer.227

³⁰³ Bernheimer. 229

³⁰⁴ Yates, *The Art of the Memory*.157

³⁰⁵ Hooper-Greenhill, *Museums and the Shaping of Knowledge*.101

symbolism of Greek mythology. The primary concepts attributed to each row were symbolized by mythological events, places, creatures, and gods. As one went up the Theatre by the gangways of the seven planets, the entire story of the creation would unfold as an ordered representation. First there was the appearance of “interior man”, the most noble creature of God. Then, man took on a body the parts of which are under the domination of zodiac. The “interior man” was created the divine and had the power of the star rulers. On falling into the body, man came under the domination of the stars. Men could be freed of this domination through the hermetic religious experience of ascent through the spheres to regain his divinity. According to Camillo, the Theatre was the system of memory places and by looking down on it from above the whole universe could be remembered.³⁰⁶

Through the Theatre macrocosm became something that could be stored in the mind by means of memory. The mind and memory of human became “divine”, having powers if grasping the highest reality, the eternal truth, the secret of the universe.³⁰⁷ The astonishing case of the mind comprehending the immense and intricate universe was considered to be something magical. As stated by Hooper-Greenhill, “the memory became a mystical tool for grasping the relationships of the world and reuniting man with God.”³⁰⁸

The magical system of Camillo was functioning by using the memory images as “inner talismans”³⁰⁹. Occult links to the secret orderings of the universe, revealed through talismanic imagery made the Memory Theatre a privileged apparatus shaping knowledge and bringing authority on many levels such as celestial/terrestrial and magical/material.³¹⁰ The Theatre of Camillo is described in the writing of Dutch statesman Viglius Zuichemus to Erasmus as:

³⁰⁶ Yates, *The Art of the Memory*.143

³⁰⁷ Yates.138

³⁰⁸ Hooper-Greenhill, *Museums and the Shaping of Knowledge*. 101

³⁰⁹ At that time, talismans were objects imprinted with an image that rendered it magical by having been made based on certain laws. The inner use of talismanic imagery gave the memory the power to combine the contents of the mind. (Hooper-Greenhill.100)

³¹⁰ Hooper-Greenhill. 100

“He calls this theatre of his by many names, saying now that it is a built or constructed mind and soul, and now that it is a windowed one. He pretends that all things that the human mind can conceive and which we cannot see with the corporeal eye, after being collected together by diligent meditation may be expressed by certain corporeal signs in such a way that the beholder may at once perceive with his eyes everything that is otherwise hidden in the depths of the human mind. And it is because of this corporeal looking that he calls it a theatre.”³¹¹

In basic terms, the Theatre of Camillo was an impressive composition of space, image and text aiding the remembering of the entire knowledge of the universe in an occult way.

Corporeal elements of architecture and art were brought together for the embodiment of knowledge. Memory and the mysterious process of remembering were materialized in the space of the Theatre. The art of memory which had been a completely mental process turned into a physical practice. The concept of mental imagery was replaced with the physical imagery. The activity of the “mind’s eye” was replaced with the activity of the “corporeal eye”.

At the beginning of the seventeenth century, the concept of Memory Theatre appeared in a new form in England. Among English occult philosophers, Oxford physician Robert Fludd comes to the fore with his “Theatre Memory System,”³¹² described as the “last great monument of Renaissance memory”.³¹³

³¹¹ Yates, *The Art of Memory* quoted in Hooper-Greenhill.97

³¹² In a specific chapter in his book *De utriusque cosmi historia* (History of Two Worlds), Fludd discusses the art of memory and defines two different types of art: “round art (*ars rotunda*)”, and the “square art (*ars quadrata*)”. The “round art” used occult or talismanic images like star figures and statues of gods and goddesses. On the other hand, “square art” used the images of corporeal things such as human, animals or inanimate objects. The “square art” was similar to the ancient art of memory described in *Ad Herennium* and it was possible that the term “square” was chosen since buildings or rooms were used as memory *loci*. Fludd was against the use of fictitious places, therefore, he preferred “real” buildings in his memory system. Essentially, the memory system of Fludd was a combination of these round and square arts. It was based on the round heavens, the zodiac and the spheres of the planets, combined with buildings containing places with memory images which were activated by being organically related to the stars. (Yates, *The Art of the Memory*.326-327)

³¹³ Yates.321

According to Yates, the remarkable aspect of this system was that he called the memory buildings placed in the heavens as “theatres”.³¹⁴ Fludd’s memory system used theatre as its architectural form like the Theatre of Camillo which he might have heard during his visit to France.³¹⁵ It is also possible to read the similarities between Fludd’s system and the work of Giordano Bruno, where he used sets of atria or rooms, cubicles and fields filled with images and activated by being organically related to “round” art, the images in which were gods and goddesses to whom celestial influences were attributed.³¹⁶ Moreover, there is another possibility that Fludd came across with the writing of John Willis published in 1618 in England, in which a memory system of sets of identical theatres or memory rooms were suggested as *loci*. Willis referred to these memory rooms as “theatres” but also as “repositories”.³¹⁷

The “theatres” in Fludd’s system were the representatives of “square art” and they were associated with the “round” heavens by being placed in the zodiac. The round and square art were united to form a complex occult memory system based on the macrocosm-microcosm relation.

Fludd’s masterpiece *De utriusque cosmi historia* (History of Two Worlds), published in three volumes in Frankfurt between 1617 and 1619 included diagrams and drawings depicting his memory system. A diagram showing the “ars rotunda”, or the natural order of memory places, included eight enclosing circles, seven of them representing the spheres of the planets, and the eighth sphere representing the zodiac, marked with the signs of the zodiac. On either side of the sign Aries, two small buildings were drawn which were “theatres” having two doors at the back.³¹⁸ (Fig.73) Facing this diagram of heavens, on the next page of the book, there was an engraving of a “Theatre”. Regarding this, Yates wrote:

³¹⁴ Yates.329

³¹⁵ Yates.321

³¹⁶ Yates.329

³¹⁷ Hooper-Greenhill, *Museums and the Shaping of Knowledge*.109

³¹⁸ Yates, *The Art of the Memory*. 330

“The diagram of the heavens and the picture of the ‘theatre’ are placed on opposite pages in such a manner that, when the book is closed, [the] heavens cover [the] theatre.”³¹⁹

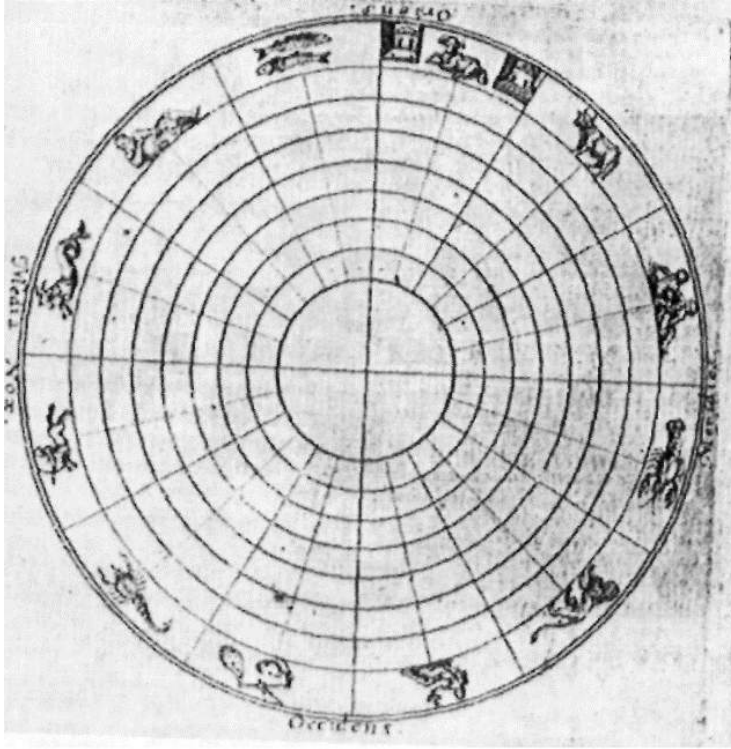

Figure 73. The Zodiac from Robert Fludd's *Ars Amemoriae* (p. 329)

Source: Frances Amelia Yates, *The Art of the Memory* (New York: Routledge, 1966).

Contrary to expectations, by “theatre” Fludd did not mean a building including a stage and an auditorium, he only meant a “stage”. He described it as follows:

“I call a theatre (a place in which) all actions of words, of sentences, of particulars of a speech or of subjects are shown, as in a public theatre in which comedies and tragedies are acted.”³²⁰

³¹⁹ Yates. 330

³²⁰ Yates. 331

In his statement, he underlined the function of his theatre as a memory place system for the remembrance of words, sentences, or subjects. He also mentioned that his theatre was similar to the “public theatres”, the spacious wooden theatres in where the plays of Shakespeare and other great writers’ were performed. In this context, in the “theatre” engraving only a “stage” was depicted. The wall facing the reader was the *frons scaenae* (front scene) and included five entrances as in the classical *frons scaenae*.³²¹ Nevertheless, it could not be directly referred to as a classical stage. Rather, it was more similar to the English Renaissance theatre (Elizabethan or Jacobean theatre) having a multilevel stage. Three of the entrances, two of them were arch formed, were on the ground level. The central one could be closed by hinged doors. The other two entrances were on the upper level and opened to a battlemented terrace. In the center there was a bay window, or an upper room which was a remarkable element, visually dominating the image. On the bay window the phrase “*Theatrum Orbi*”, directly translated as “World Theatre”, was written.³²²

The concept of five doors, or entrances, was an important aspect of the memory system of Fludd. The five doors in the “theatres” served as five memory *loci* which were related to the five columns opposite to them. Although the columns were not depicted in the engraving, only their bases were shown in the foreground. The bases were in different shapes. The central one was hexagonal with a square and circular one on either side. Fludd mentions that these columns were in different colors, matching with the colors of the doors. The doors used as memory *loci* were easily distinguished from one another by being remembered as different in color. In Fludd’s magical memory system, all the “theatres” had these set of ten elements, five doors and five columns for remembering the words and concepts.³²³

³²¹ The concept *frons scaenae* will be further discussed in relation with anatomical theatres and theatre architecture in Chapter 3.2.

³²² Yates, *The Art of the Memory*. 330-332

³²³ Yates. 333

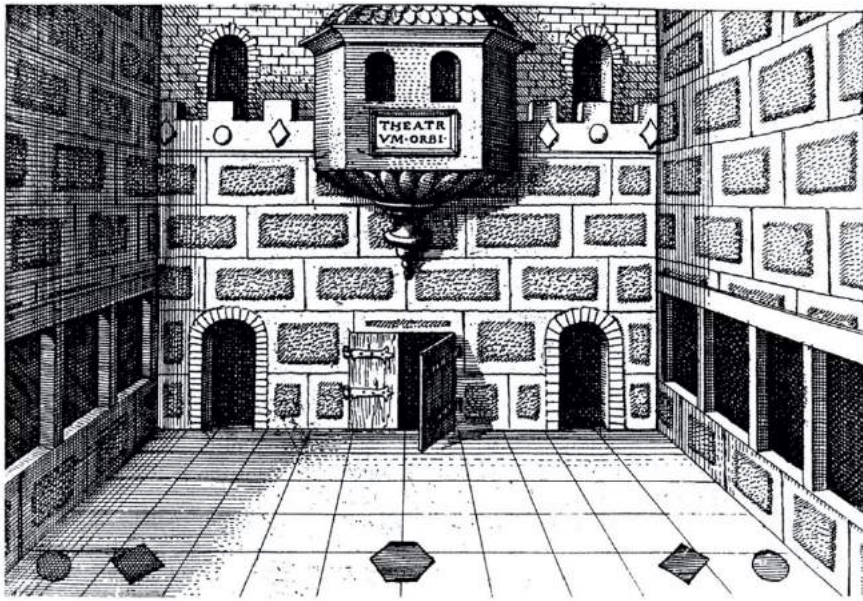

Figure 74. The Theatre from Robert Fludd's *Ars Amemoriae* (p. 330)

Source: Frances Amelia Yates, *The Art of the Memory* (New York: Routledge, 1966).



Figure 75. Sketch of The Swan Theatre which was, a typical Elizabethan theatre by De Witt, 1596.

Source: Frances Amelia Yates, *The Art of the Memory* (New York: Routledge, 1966).

The illustration on the title page of *De utriusque cosmi historia* epitomized the main idea of Fludd's memory system. The phrase written on the head of the person, "*Oculus Imaginationis*," meaning "the eye of the imagination" directly referred to the concept of "visual mental imagery", or "seeing in the mind's eye" which constituted the essence of place-based memory, as explained in Chapter 3.1.2. Similar to other memory systems, Fludd's theatre was about "seeing". It was a visual experience based on mentally re-seeing the previously seen and memorized spaces and objects. Supporting this comment, Yates described the illustration as:

"This 'theatre' or stage with its five doors to be used as five memory places is the leading motif of the whole system. We can see it adumbrated in the introductory illustration of the man seeing with the eye of imagination five memory places with their five images."³²⁴

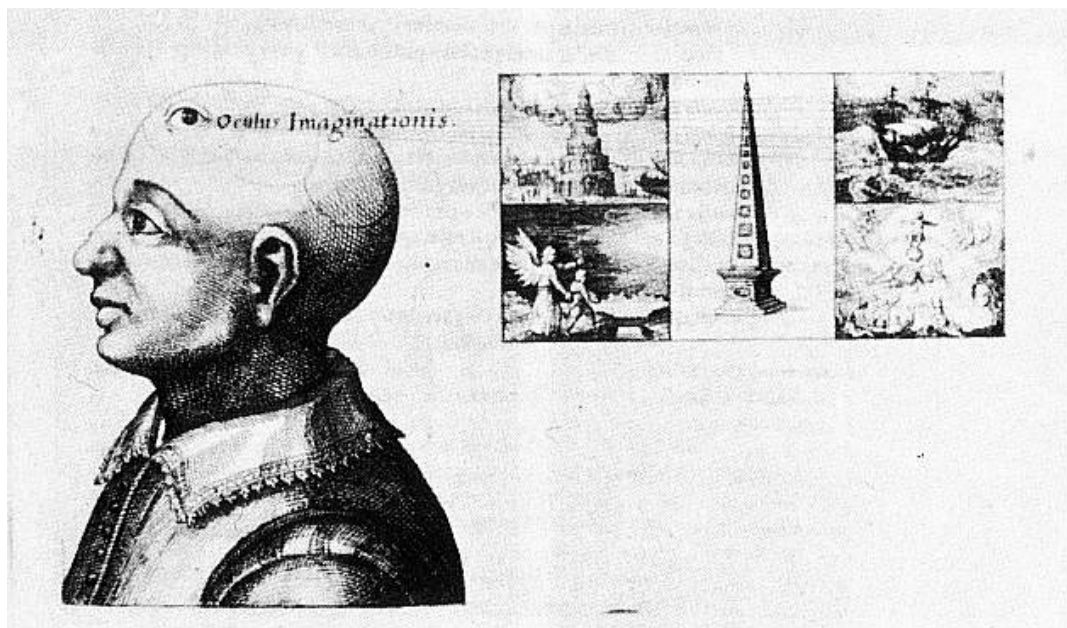

Figure 76. The illustration in the first page of the *Ars memoriae* in Robert Fludd's *De utriusque cosmi historia*, Tonus Secundus, Oppenheim, 1619

Source: Frances Amelia Yates, *The Art of the Memory* (New York: Routledge, 1966).

³²⁴ Yates.335

3.2. Architecture of Knowledge: Spaces for Seeing and Knowing

3.2.1. From Memory Theatre to Anatomical Theatre

“In an episteme in which signs and similitudes were wrapped around one another in an endless spiral, it was essential that the relation of microcosm to macrocosm should be conceived as both the guarantee of that knowledge and the limit of its expansion.”³²⁵

As mentioned in Chapter 3.1, the Renaissance vision of the cosmos was based on macrocosm-microcosm duality and their complex relation. Macrocosm represented the universe/the Creator and its product “nature”, while microcosm stood for the human-being and “art” as its product, they were believed to be the reflections of each other and their coexistence created the “cosmos”, the harmonious and perfectly-ordered whole. This conception of the universal ordering was quite significant since it was presumably the first consistent formulation of a relationship between the human body and the rest of reality. In this cosmological framework, the memory theatre, which aimed to establish a “world-picture” by gathering the entire knowledge of the universe to be understood, known and remembered by the microcosm, was highly related to the concept of anatomical theatre, which was a space designed for understanding, knowing and remembering the microcosm while itself, representing the macrocosm. To better understand the links between the memory theatre and the anatomical theatre, it is necessary to start by looking closer to the works of Robert Fludd and the context that they were created. Fludd was a prominent representative of an intellectual current called Rosicrucianism.³²⁶ The

³²⁵ Foucault, *The Order of Things: An Archeology of the Human Sciences*.³⁵

³²⁶ Rosicrucianism was a spiritual and cultural movement which arose in Europe in the early 17th century, proposing a complete renewal of the natural sciences based on a thorough understanding of the Hermetica (*Corpus Hermeticum*), Egyptian-Greek wisdom texts from the 2nd century or earlier, forming the basis of Hermeticism and the world of natural magic associated with it. The main goal of this movement was to reform the whole human understanding of Creation. In many respects the Rosicrucian movement was a revival of the Renaissance Neo-Platonism, combined with later influences, especially the alchemist teachings of Paracelsus. (Tim Huisman, “The Finger of God: Anatomical Practice in 17th-Century Leiden” (PhD Thesis, Leiden University, 2009).)

defenders of this movement were well aware of the significance of the scientific collections for the reformation of natural sciences.³²⁷ In the writings of Fludd, there were many references to collections as instruments of investigation and speculative science. *De utriusque cosmi historia* places emphasis on scientific collections, or as they were often called “Theatres of Wisdom” (*Theatra Sapientiae*). The ambition of Fludd’s book was to describe the whole of creation in one comprehensive system, based on the theory of macrocosm and microcosm.³²⁸

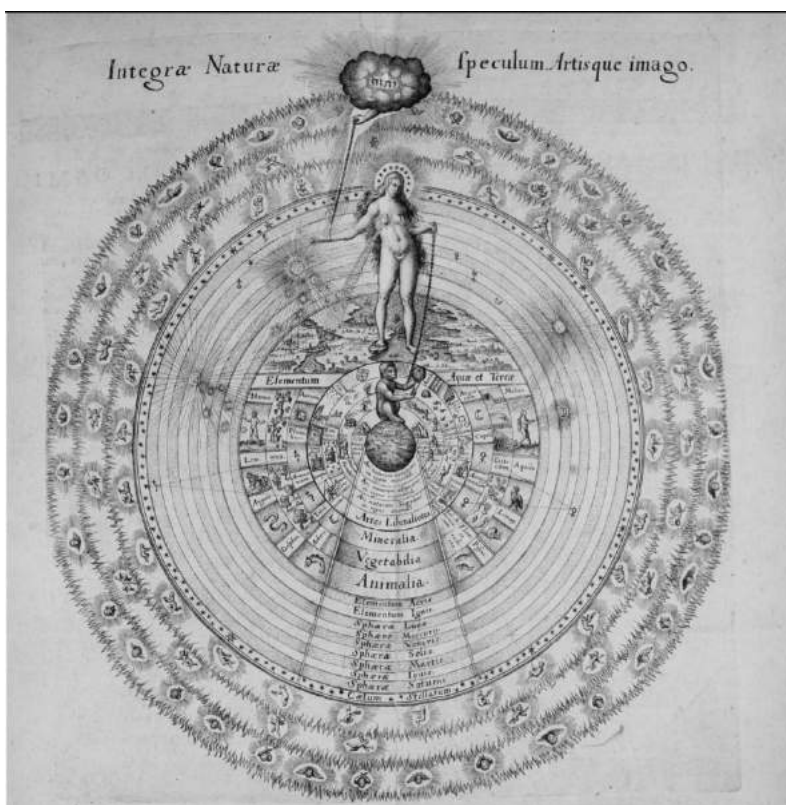

Figure 77. The Mirror of the Whole of Nature and the Image of Art by Robert Fludd, 1617. Colors edited by the author.

Source: Tim Huisman, “The Finger of God: Anatomical Practice in 17th-Century Leiden” (PhD Thesis, Leiden University, 2009).⁶⁸

³²⁷ Elias Ashmole, who was an English physician like Fludd, was also a well-respected Rosicrucian. More importantly, Ashmole is known as the father of Ashmolean Museum (1683) in Oxford, the first university museum in the world, as he donated his invaluable collection, which was a sort of “cabinet of curiosities” including priceless books, manuscripts and natural history objects to the University of Oxford in 1682 to create Ashmolean Museum. (“History of Ashmolean,” accessed July 8, 2020, [https://www.ashmolean.org/history-ashmolean.](https://www.ashmolean.org/history-ashmolean))

³²⁸ Huisman, “The Finger of God: Anatomical Practice in 17th-Century Leiden.”⁶⁷

In the volume on the macrocosmos, *De utriusque cosmi majoris historiae* (1617), Fludd presents an elaborate diagram showing the relationships between nature and art named as *Integrae Naturae Speculum Artisque Imago* (Mirror of the Whole of Nature and Image of the Arts). In concentric circles the domains of God, nature and human are represented; from the outer spheres of the angels and spirits, through the celestial sphere of the firmament to the spheres of the planets, to the sublunar sphere of terrestrial nature.^{329 330}

This diagram is quite important in terms of portraying how the cosmos and the relations between macrocosm and microcosm was imagined by the intellectuals of the seventeenth century. It also sheds light on the organization and structuring of the “cabinets of the world”, such as *Kunstkammern* and the Memory Theatre. It is probable that the hierarchical cosmologies like Fludd’s have shaped the design of the early collections and systems of display and defined their order. As mentioned in the previous chapter, “Memory Theatre” the main focus of Fludd was to establish a memory system. Therefore, his diagrams were in fact memory aids or mnemotechnic devices.

Fludd trained as a physician in Oxford University and was a member of the Royal College of Physicians. Considering that, the links between his medical background and the diagrams in his book showing the cosmological order and the position of the microcosm, the human, with respect to the macrocosm cannot go unnoticed. His professional interest in the human body might be the essence of his urge to understand the microcosm. Paracelsus’s dictum stating that “there is nothing in man

³²⁹ Huisman. 68

³³⁰ The sublunary world contains the elements of fire and air, which move upwards to the skies, and earth and water, which are pulled downwards to the world. Under the patronage of these elements, three realms of nature is depicted: vegetable, mineral and animal. Nature is personified by a naked woman figure held on a chain by the hand of God. The monkey “the Ape of Nature”, represents the art/artificial or the microcosm, human who makes art, held on a chain by the woman figure symbolizing the nature.³³⁰ The domain of human is reserved for the *artes* (arts). There are the *artes liberaliores* (the free arts) and the *artes mechanicae*. The mechanical arts are in turn divided according to the three realms of nature: *ars naturam corrigens in regno minerali* (which is alchemy), *ars naturam corrigendo in regno vegetabili* (agriculture) and *ars naturam corrigendo in regno animali* (to which medicine belongs). (Huisman.68)

that is not also in nature and nothing in nature that is not also in man”³³¹ reflected the common belief of the time, suggesting a direct relationship between macrocosm and microcosm. This understanding was crucial for decoding the ties between anatomy education and practice and the perception of the cosmological order.

In Renaissance Europe, anatomy was beyond just being a scientific field studying the structural composition of the human body, it was seen as a sublime practice. It was considered as an artistic and spiritual exploration of life, disease, and death. In that respect, anatomical theatre was seen as “a place to witness the celebration of life through the analysis of death, and a place to be captivated by science.”³³² Beyond that, in a setting where the human body was considered as a representation of the universe, knowing the body was knowing the universe and its perfect, yet complex order. As the concept of macrocosm corresponded both to the universe - the knowledge of the universe - and to the celestial power - the divinity- microcosm was also a reflection of both. It was believed that the wisdom of God was manifested in the human anatomy, therefore the study of the human body was a spiritual act.³³³ The correlation between anatomical scholarship and the cosmological understanding was embodied in the anatomical theatre. Within this context, it is possible to say that anatomical theatre was a mediation between the microcosm and macrocosm, a space for reuniting human with God. It was like a “transition” space connecting the material to the spiritual, the body to divine, the human to the universe.

One of the earliest anatomical theatre structures *Theatrum Anatomicum* in Leiden (1594), is an important case epitomizing the interactions between the cosmological view of late Renaissance shaped around the concepts of microcosm and macrocosm and the anatomy education and practice. It was an impressive place including a circular amphitheater with six tiers around a rotatable dissection table adorned with human and animal skeletons. (Fig.78) Skeletons were both instruction material and

³³¹ Huisman.158

³³² Veronica Papa et al., “The Teaching of Anatomy Throughout the Centuries: From Herophilus to Plastination and Beyond,” *Medicina Historica* 3, no. 2 (2019): 69–77. 71

³³³ Huisman, “The Finger of God: Anatomical Practice in 17th-Century Leiden.”93

decoration elements for the theatre. The skeletons together created an expression of *memento mori*, the artistic and symbolic reminder of the inevitability of death.

Describing it as an anatomical theatre would be insufficient since it was also a cabinet of curiosities regarding the extensive collections it accommodated. In addition to the collection of skeletons, natural curiosities and artefacts were on display in and around the theatre. The expression “even when one had a thousand eyes, a full day would not suffice to see all the mysterious and curious objects [of the theatre]” written in 1630, became a figure of speech and repeated in many travelogues till the 18th century, highlighting the greatness of the collection of Leiden Anatomical Theatre.³³⁴

In this context, it is possible to associate the Anatomical Theatre of Leiden with the diagrams of Fludd depicting macrocosm and microcosm. The concentric circular tiers in the plan of the anatomical theatre could be interpreted as seven concentric circles representing the planetary system in Fludd’s diagram. Also, the collection objects including human and animal skeletons, dried animal and plant specimens disposed on the tiers could be seen as a reflection of the three realms of nature: vegetable, mineral and animal presented in the diagram. In the center of this model of macrocosm there was the dissecting table where the human body, the microcosm, was displayed like in the diagram of Fludd. Huisman describes the relation between the idea of microcosm-macrocosm and the Leiden Anatomical Theatre as:

“The microcosmos-macrocosmos concept that was a characteristic feature for Paracelcist and Rosicrucian medical scientists such as Robert Fludd can also explain the presence of...collection within the whole of the Leiden anatomical theatre. The collection represented the macrocosmos – nature – surrounding the microcosmos – man – which was represented by the anatomical subject on the dissecting table.”³³⁵

³³⁴ Huisman. 10

³³⁵ Huisman.158

This setting also underlined the dictum of Paracelsus in terms of embodying the idea that the knowledge of nature was essential to obtain the knowledge of the human body and vice versa.

Beyond the relationship between the *Theatrum Anatomicum* and the diagram of Fludd, the placement of the collection objects on the ascending tiers in circular form also reminds the Memory Theatre of Camillo.

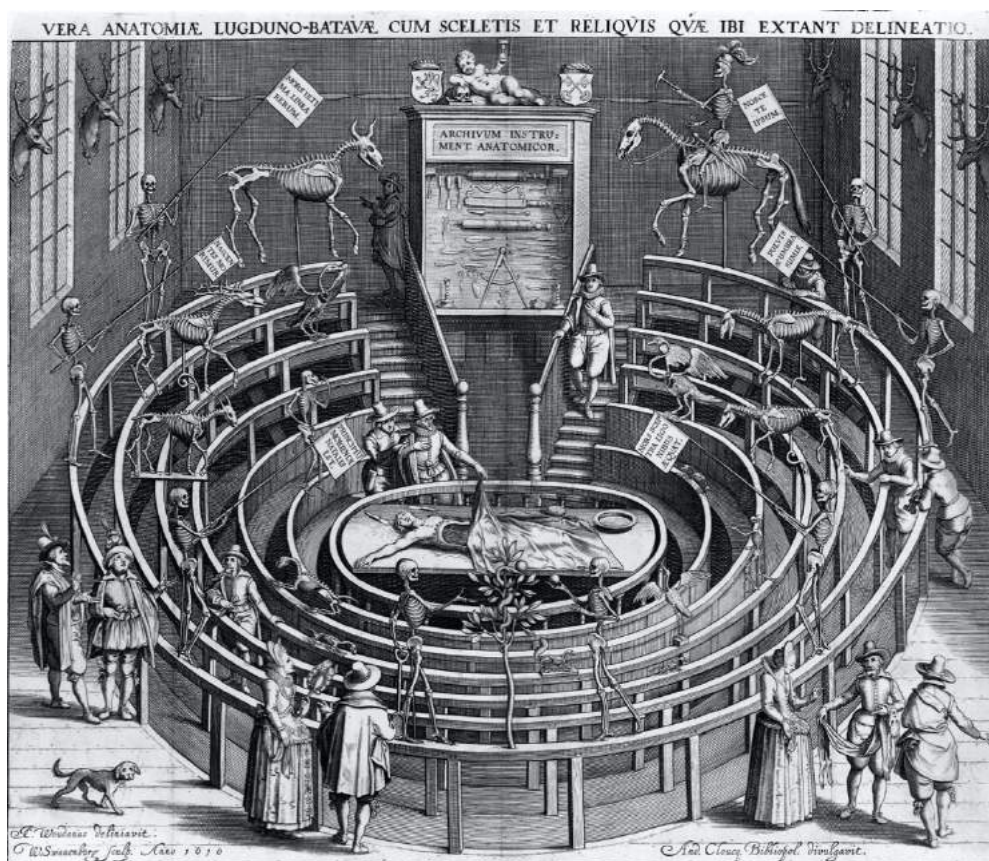

Figure 78. Engraving depicting the Leiden Anatomical Theatre by Willem van Swanenburgh after Jan Cornelisz. van't Woud (Woudanus), 1610

Source: Tim Huisman, "The Finger of God: Anatomical Practice in 17th-Century Leiden" (PhD Thesis, Leiden University, 2009). 38

In a similar fashion, Bologna Anatomical Theatre (1637) located in the Archiginnasio Palace, also carries the traces of Fludd's cosmological memory system. The ceiling of the theatre is paneled by wooden decorations symbolizing fourteen constellations arranged around the figure of Phoebus, the Greek god of

medicine. Phoebus is located inside an octagonal frame. The choice of octagon shape is not coincidental as “the number 8 symbolizes a spiritual eighth day of the week representing the new world after Christ’s resurrection.”³³⁶ (Fig. 79)

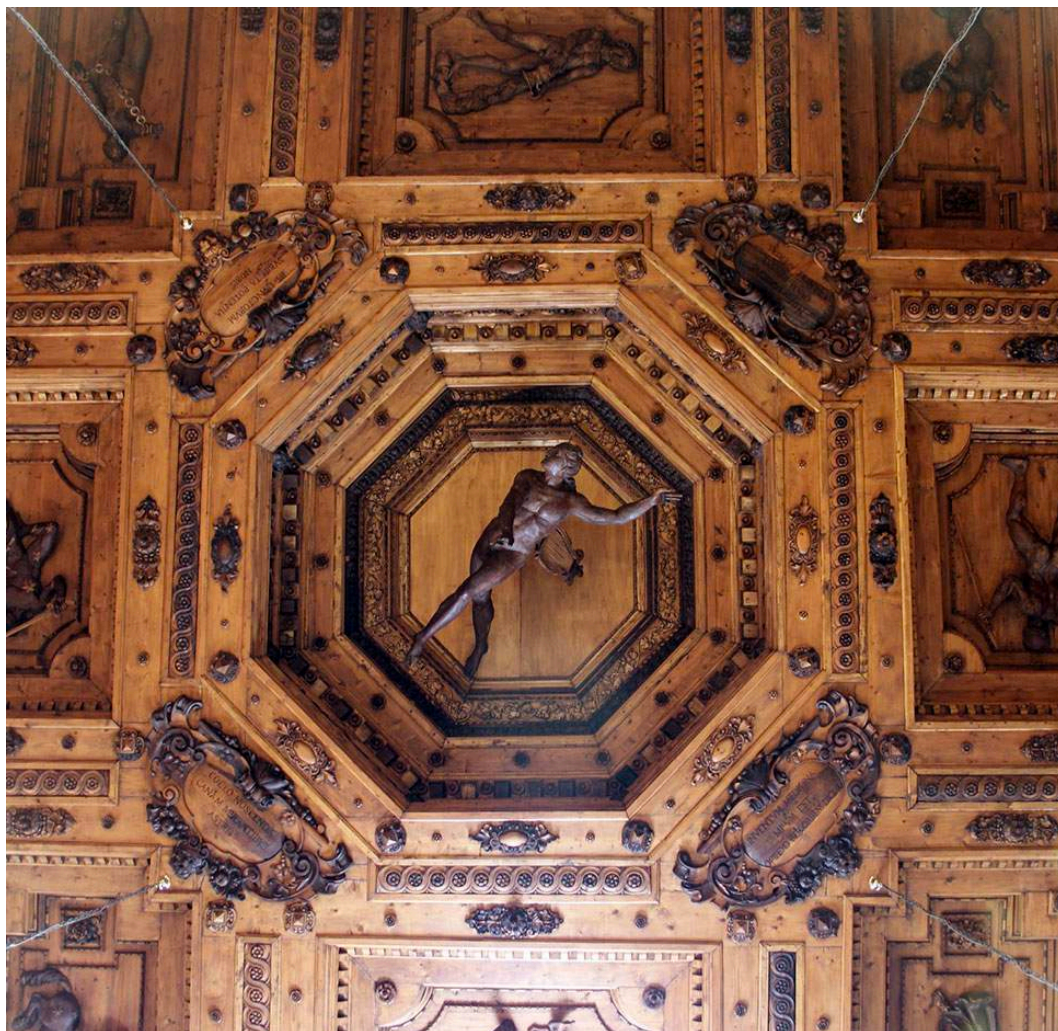

Figure 79. The ceiling of Bologna Anatomical Theatre

Source: Berardo Di Matteo et al., “Art In Science: The Stage of the Human Body—The Anatomical Theatre of Bologna,” *Clinical Orthopaedics and Related Research* 473, no. 6 (2015): 1873–78, <https://doi.org/10.1007/s11999-015-4288-8>. 1876

As an allegorical setting the ceiling represents the skies, the perfect order of the universe and the glory of God, the macrocosm in general. The dissection table

³³⁶ Berardo Di Matteo et al., “Art In Science: The Stage of the Human Body—The Anatomical Theatre of Bologna,” *Clinical Orthopaedics and Related Research* 473, no. 6 (2015): 1873–78, <https://doi.org/10.1007/s11999-015-4288-8>. 1875

located right below the ceiling is a representation of the microcosm. Supporting this claim, under the table there is a hexagonal shape consisting of six equilateral triangles which is believed to represent Venus, the god of carnal love. This refers to the corporeality of the human, detached from the unreachable divine.³³⁷

When viewed from above, the projection of the ceiling representing the macrocosm was superimposed with the dissection table symbolizing and physically accommodating the microcosm, just like the diagram of heavens and the engraving of a theatre in *De utriusque cosmi majoris historiae* overlapping when the book is closed. (Fig. 80)

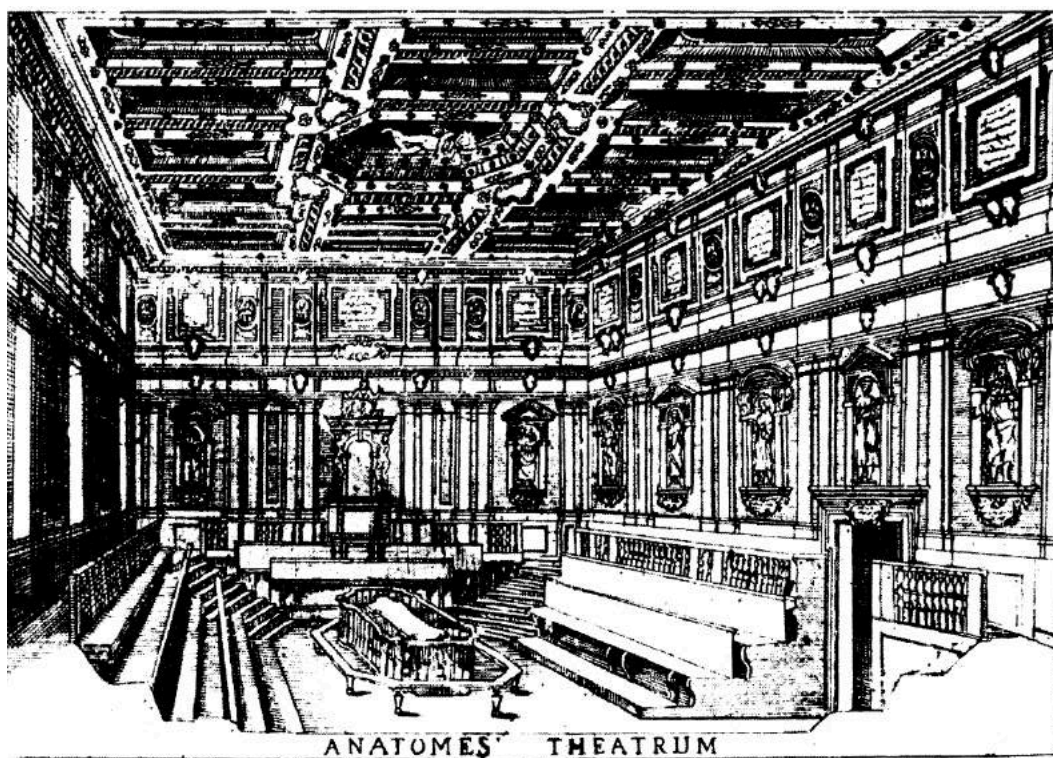

Figure 80. The Bolognese Anatomy Theatre after the eighteenth-century alterations from G. Tonelli, “Sul teatro anatomico dell’ Archiginassio”, *Strenna Storica Bolognese*, xxviii (1978)

Source: Giovanna Ferrari, “Public Anatomy Lessons and the Carnival: The Anatomy Theatre of Bologna,” *The Past and Present Society*, no. 117 (1987): 50–106, <http://www.jstor.org/stable/650788>. 77

³³⁷ Di Matteo et al. 1876

In addition to conceptual links between Bologna Anatomical Theatre and Fludd's memory system, it is also possible to argue that the Bolognese Theatre and the theatre engraving in Fludd's book have common architectural aspects. (Fig.74-81) Primarily, both spaces have rectangular form and levelled organization. The hexagonal shape under the dissection table and the hexagonal base of the central column in Fludd's theatre show similarity. The geometric composition of the wall facing the entrance of Bologna Anatomical Theatre bear resemblance to the *frons scaenae*. Although there is no direct reference to the relation between these two spaces, the mentioned similarities are quite evident and suggest an indirect association between them.

As examined upon two significant anatomical theatres, it is possible to argue that the anatomical theatres were conceptually, the continuation of the memory theatre convention.



Figure 81. A view of the Anatomical Theatre of Bologna showing the wall facing the entrance

Source: Di Matteo et al., "Art In Science: The Stage of the Human Body—The Anatomical Theatre of Bologna." 1874

3.2.2. Museum, Theatre and Library

As mentioned previously, to be able to fully understand the emergence, development, status and importance of the spaces created for anatomical scholarship, specifically the anatomy museum and the anatomical theatre, the associations between the “museum” and “theatre” must be explored on a theoretical basis. Within this framework, the concept of “library” also relates to the concepts of “museum” and “theatre” in different aspects and creates a multimodal network of relations. Before going into the details of the anatomical theatre architecture, it is necessary to portray a holistic view by unfolding and examining these relations.

In *The Order of the Things*, Foucault describes an “encyclopedic project” that emerged at the end of sixteenth-beginning of the seventeenth century, which intended to reconstruct the order of the universe in a way where words were linked together and organized in space.³³⁸ The form and structure of language was seen to be analogous to the form and structure of the world that it represented. Within this context, all the languages in the world were taken together, in their interlacing and in their positioning in space, analogically made up the truth of the world.³³⁹

Foucault refers to Cristophe de Savigny who found a way to spatialize acquired knowledge in the form of the circle and in accordance with the sublunary, perishable, multiple and divided form of the tree. This was also found in the work of La Croix du Maine, who envisaged a space that was both an encyclopedia and a library that would allow the arrangement of the written texts according to the forms of adjacency, kinship, analogy and subordination reflecting the order of the Renaissance world which was dominated by relations of resemblance: *convenientia* (a relationship of contiguity), *aemulatio* (a relationship of imitation or echo), *analogia* (a relationship of affinity or homology), and *sympathia* (a relationship of proportion or action over

³³⁸ Foucault, *The Order of Things: An Archeology of the Human Sciences*. 42

³³⁹ Foucault *Order of the Things* 1970:37 quoted in Hooper-Greenhill, *Museums and the Shaping of Knowledge*.101

distance) as defined by Foucault.³⁴⁰ This clearly manifested the idea of implementing the order of the world as an organizing principle for the written texts, thus the knowledge.

Hooper-Greenhill argues that the concept of the “cabinet of the world” was a prototype of this encyclopedic project which embraced both the space of the library and the space of the theatre. She says that the “cabinet of world” was Camillo’s Memory Theatre made material, existing in physical form³⁴¹ although Gilbert Cousin declared in his writing with the date 1558, that he had seen the Theatre of Camillo at the court of France³⁴². Within this context, the arrangement of the objects in the Memory Theatre or the “cabinet of the world” would be according to *convenientia*, *aemulatio*, *analogia* and *symphtia*.³⁴³ The similarity between the spatial orders of these Renaissance structures may have underlay the links between the spaces of knowledge: museum, library and theatre.

During the sixteenth and seventeenth centuries the word “museum”³⁴⁴ was rarely used for describing the spaces with collections. When used, it was used in Latin, loosely meaning a particular place where the “muses” were studied. Mostly, it referred to a room for reading.³⁴⁵ Edward Philips’s *New World of English Words: Or, Universal English Dictionary* (1706) “gave four definitions of ‘museum’; as a

³⁴⁰ Foucault, *The Order of Things: An Archeology of the Human Sciences*.42

³⁴¹ Hooper-Greenhill, *Museums and the Shaping of Knowledge*.102

³⁴² Bernheimer, “Theatrum Mundi.”226

³⁴³ Hooper-Greenhill, *Museums and the Shaping of Knowledge*.102

³⁴⁴ The word “museum” has classical origins. It comes from the Greek word *mouseion* meaning the “temple or shrine of the Muses”. According to Hesiod, who is known as the pioneer of Greek didactic poetry, the nine Muses were the daughters of Mnemosyne, the goddess of memory, and Zeus. The Muses were the inspirational goddesses of arts and sciences, therefore the sources of the knowledge that preserved and conveyed through oral aids like poetry, songs and myths in ancient Greece. (Hesiod, *Theogony Works and Days Testimonia*.) Therefore, *mouseion* referred to an institution for the study of arts and philosophy or a place of contemplation. The *Musaeum* or *Museion* at Alexandria, founded by Ptolemy I Soter in early 3rd century BCE, was a philosophical school and home of music and poetry and included the famous Library of Alexandria. Although the contemporary concept of a museum evokes the idea of a building hosting a collection or multiple collections, *Museion* at Alexandria did not have any collections. Instead, it was an institution gathering the distinguished scholars of the Hellenistic world, setting a prototype for modern universities. Despite its function, *Museion* was the inspiration for the modern usage of the word “museum”. (<https://www.britannica.com/topic/museum-cultural-institution>)

³⁴⁵ Hooper-Greenhill, *Museums and the Shaping of Knowledge*.89

study; a library; a College; or a ‘Publick Place for the Resort of Learned Men.’”³⁴⁶ The meaning of the word as a building or a part of a building devoted for the display of the objects relating to art, literature or science is recorded towards the end of the seventeenth century.³⁴⁷

In addition to the etymological connection relating the museum to the library, there is also a functional association between them. Simon Chaplin argues that “[a]n examination of museums as functional spaces can usefully be broadened to consider analogous kinds of repositories, such as libraries.”³⁴⁸ Enhancing the statement of Chaplin, it must be highlighted that beyond being repositories, both museums and libraries are spaces that function as display environments in different ways.

During the 18th century, the kinds of collections a museum had and the activities that took place in it were quite ambiguous. For instance, the new British Museum opened in 1759, comprised collections of books and manuscripts as well as other kinds of objects. It was not until 1973 that the British Library became a separate national institution. This epitomizes the continuation of the older tradition of the museum as a place of learning. Text-based and object-based study were closely related concepts, therefore the physical structure accommodating them could be common. In that sense, the studies on the architectural history of libraries, museums and galleries underline the fact that all these seemingly distinct spaces suggest a shared ancestry. Although, towards the end of the 18th century, the museums and libraries began to be designed as separate spaces, a more in-depth analysis of their structure and collections disposed in them erases the distinction.³⁴⁹

In modern usage the term “museum” bears loaded meanings. Among these meanings, the primary one refers to a defined physical space where collected objects

³⁴⁶ Michael Hunter, *The Cabinet Institutionalized: The Royal Society’s “Repository” and Its Background*, 1985. 226-227 in Arthur MacGregor and O. R. Impey, eds., *The Origins of Museums: The Cabinet of Curiosities in Sixteenth and Seventeenth-Century Europe* (Oxford: Clarendon Press, 1985). 217-229

³⁴⁷ Hooper-Greenhill, *Museums and the Shaping of Knowledge*. 89

³⁴⁸ Chaplin, “John Hunter and the ‘Museum Oeconomy’, 1750-1800.” 167

³⁴⁹ Chaplin. 167

are arranged to view. Broadening the basic meaning, current professional and academic definitions of “museum” involve manifold implicit or explicit statements regarding the uses of these collections. Despite the nominally defined boundaries between the idea of a museum and a library today, the historical bonds conceptually relating them are still visible. As Chaplin wrote “even today, distinctions between museums and other kinds of repository or exhibition space – libraries, archives, art galleries – are frequently blurred.”³⁵⁰

When the case of anatomy museums is examined, it is seen that in most of them, text-based material, such as anatomical atlases³⁵¹, illustrated books, and manuscripts were and continue to be an important part of their collections. The most striking example could be the Hunterian Museum in Glasgow accommodating the extensive book and manuscript collection of William Hunter.

³⁵⁰ Chaplin. 161

³⁵¹ An anatomical atlas is a comprehensive and detailed textbook, including a compilation of all the drawings of each region of the human body, with labels on each drawing.



Figure 82. William Hunter and the Anatomy of the Modern Museum exhibition (September 2018-January 2019) in Hunterian Museum, Glasgow

Source: The Hunterian (@hunterian). 2019. "Closes Sunday 6 January - open today 10am to 5pm 'William Hunter and the Anatomy of the Modern Museum'. An extraordinary man and an extraordinary collection. Hunterian Art Gallery." Twitter, January 4, 2019, 12:32 pm. <https://twitter.com/hunterian/status/1081121225181724672>

Between museum and theatre there is a multilayered relationship like the one between museum and library. It is important to first elaborate on the term "theatre" and its different meanings besides the well-known ones such as a building or outdoor area where spectacles, plays or dramatic performances are given or those presentations themselves. In Middle Ages, the word "theatre" was used to denote a place of assembly, or a commerce space where the goods on display are organized in ranks, following a certain order. An alternative early meaning of the word "*theatruni*" referred to a complete display of a certain kind of specimen. During the Renaissance the word "theatre" referred to a compilation or compendium. In late sixteenth century, it was frequently used in the documents to demonstrate a complete

treatment or compilation of a particular theme. In general, the concept of theatre referred to abstractions, usually representing the “world view”.³⁵²

All these different uses and meanings of the word “theatre”, *theatrum* in Latin, underlines its close relation to the concept of museum. Regarding this, Ekman stated that:

“The Latin *theatrum* and museum were used interchangeably to designate repositories for collections in the sixteenth and seventeenth centuries. As theatre, the repository became associated with the visual technology known from the Roman circular amphitheatres in Rome and Verona, the Vitruvian semicircular theatre, theatres of knowledge like those of Giulio Camillo and Heinrich Khunrath and encyclopaedic models drawn up in treatises named accordingly, for instance *Theatrum mundi*, *Theatrum Vitae humanae* etc.”³⁵³

As mentioned by Ekman, the Memory Theatre of Giulio Camillo, examined in detail in Chapter 3.1.3, is a prominent example in terms of carrying both the contemporary and the historical meanings of the term “theatre” and epitomizing the correlation between theatre and museum in spatial, functional and conceptual terms. Although the project of Camillo was named as “theatre”, when its distinctive characteristics and the activities that took place there are analyzed, it becomes possible to describe it as “a museum having the architectural form of a theatre.”

Primarily, it is possible to consider the Memory Theatre as a museum since its ascending circular tiers were filled with manifold objects instead of people. In the Theatre the objects of scientific, artistic and cultural interest were displayed in an orderly manner. Although the objects were selected and grouped to represent the entire world or present a “world picture” and their peculiar organization was based on mythological and allegorical systems, the idea of classification and order is the foundation of museum culture. Unlike the disordered and systematically incomprehensible curiosity cabinets, the Memory Theatre was much more closer to

³⁵² Bernheimer, “Theatrum Mundi.” quoted in Hooper-Greenhill, *Museums and the Shaping of Knowledge*. 98

³⁵³ Ekman, “Spatial Orders of Memory and Knowledge: Architectural Schemes for Collections in Seventeenth-Century Sweden.” 149

the concept of a modern museum in terms of bearing a reasonable and explicit order organizing the pile of seemingly irrelevant objects.

Secondly, in a traditional theatre the ascending rows surrounding the central space - the scene- are expected to be occupied by a crowd gathered to watch a spectacle. While the spectators are watching from the peripheral area, the display takes place at the central space. The Memory Theatre reverses this setting. In the Theatre, different from a conventional theatre organization, the display is placed along the circumferential rows and the visitors get to enjoy it from the central area for an overall view. Yates expresses this condition as:

“The solitary 'spectator' of the Theatre stands where the stage would be and looks towards the auditorium, gazing at the images on the seven times seven gates on the seven rising grades.”³⁵⁴

Also the Theatre of Camillo was designed to walk into rather than just look at, therefore the spaces where coffers were placed must have been accessible to people through the entries and passages in human scale.³⁵⁵ This meant that the visitors could walk through the passages between the distinct assembly of objects which makes it similar to a museum environment. In other words, the static audience of the theatre was converted to a dynamic and central figure through the Memory Theatre which makes it more similar to a contemporary museum.

Even though Camillo's project presented all these features that are identified with museum space, formally it was a theatre and it used the “visual technology of a theatre”.

The Memory Theatre of Camillo is a very clear example for showing the common grounds of museum and theatre. Besides that, there were other cases supporting this argument. When discussing the early collections that relate most to “museums”, the discussion generally centers around the *Kunstammer*. Samuel Quiccheberg, the

³⁵⁴ Yates, *The Art of the Memory*. 137

³⁵⁵ Bernheimer, “Theatrum Mundi.”227

Bavarian Duke Albrecht V's Flemish advisor on artistic matters, in 1565, refers to the Munich *Kunstammer* as "*Theatrum*" or "*Theatrum Sapientiae*."³⁵⁶ Architecturally, it was a space formed of cloister-like ambulatories, which, with four wings comprising several floors surrounding a courtyard.³⁵⁷ It is understood that, despite *Kunskammer* did not have the architectural layout of a theatre, regarding its functional similarity to the Memory Theatre, it was referred to as a "theatre". In fact, it is possible to say that all the early museums, such as *Kunstammer*, *Kunstschränke* and *studiolo*, were not formally but conceptually "memory theatres" as they were all established for the purposes of creating a "cabinet of the world", presenting a "world picture" and representing the entire knowledge of the universe to be remembered and occultly used for revealing its secret.

The anatomical theatres embody the strong bonds between theatre and museum. Among the prominent and oldest anatomical theatres in Europe, *Theatrum Anatomicum* in Leiden served both as a theatre and a museum. As mentioned in the previous subchapter, in addition to its primary function of housing the public dissection sessions, the Theatre comprised an extensive collection of human and animal skeletons, dried specimens, framed anatomical illustrations and many other natural curiosities and artefacts. In time, ethnographic objects were added from the lands discovered and surveyed by the Dutch Republic in the early 17th century such as Japanese puppets, Egyptian antiquities, Russian clothing items and Brazilian jewelries. From the 1720s on, the Theatre mainly functioned as a museum, or rather a cabinet of curiosities.³⁵⁸ Huisman explains the dual function of the Leiden Anatomical Theatre as follows:

"Closely connected to the presentation of the Leiden anatomical theatre as an institution shaped and altered by its evolving cultural context is the question of the relationship between the two functions of the theatre: anatomy place and cabinet of curiosities and rarities... The anatomical theatre housed a collection of curiosities that could be admired by the public when no

³⁵⁶ Hooper-Greenhill, *Museums and the Shaping of Knowledge*.108

³⁵⁷ Lorenz Seelig, *The Munich Kunstammer: 1565-1807* in MacGregor and Impey, *The Origins of Museums: The Cabinet of Curiosities in Sixteenth and Seventeenth-Century Europe*. 76-89

³⁵⁸ Huisman, "The Finger of God: Anatomical Practice in 17th-Century Leiden."13

dissections were taking place. A possible conflict between these two functions, 'museum' and dissection room, does not seem to exist."³⁵⁹

Beyond the functional and etymological ties, the most important feature uniting the museum and theatre is the fact that both spaces are fundamentally designed for "knowing by seeing." The spatial arrangements of both focus on the act of "seeing" for attaining knowledge and aim enhancing it through architecture. This is highly related to the idea suggested in Chapter 3.1.1, considering both museum and theatre as display spaces. By all means, the relationship between the anatomical theatre and anatomy museum complies with this argument, maybe even sets the clearest example. In this framework, Ekman wrote:

"The suite of rooms in the architecture of the seventeenth-century *Kunstammer*, like the majestic ones in Munich, Dresden and Vienna, and the circular, square or octagonal architecture of the *theatrum anatomicum*, famously filled with mounted skeletons, human skins and other preparations, as well as non-medical curiosities, as in Leiden, Copenhagen and London, appear as two spatial technologies of the same origin, enabling the visual command over specimens and artefacts, by mobile or static spectators. While the spatial arrangement of things enabled seeing in a literal sense, taxonomic ordering by means of the variables of the objects enabled them to be seen as scientific objects, as providers of knowledge."³⁶⁰

On daily basis, the books from the library and the anatomical objects from the museum were used in the dissection sessions in anatomical schools. The bodies dissected in the theatre were transformed into specimens and displayed in the museum. In most cases, libraries, anatomical theatres and museums were sharing the same building or located in adjacent structures.

The deep and complex relations established between "museum", "theatre" and "library" in Renaissance were manifested in the spaces of anatomical scholarship. All these associations had one common point which was the idea of "display".

³⁵⁹ Huisman. 12

³⁶⁰ Ekman, "Spatial Orders of Memory and Knowledge: Architectural Schemes for Collections in Seventeenth-Century Sweden." 150

Especially, the intense engagement between museum and theatre suggests importance for understanding how anatomical knowledge has been shaped through the display environments.

These links in different levels were quite significant as they also affected the spatial layout and architectural quality of these didactic spaces. Although some of these interactions between museum, theatre and library disappeared or lost their effectiveness in time, some of them still continue to be valid and influential today.

3.2.3. Theatre Architecture and the Design of Anatomical Theatres

An anatomical theatre is a large space designed for professors of anatomy or surgery to perform dissections of human or animal bodies to an audience mainly composed of medical students with the intent of teaching anatomy, the physical structure of human body. In many sources, the first permanent anatomical theatre is stated as the one built as a part of the University of Padua in 1594 that still survives. Other early examples include *Theatrum Anatomicum* of Leiden University that was put into use at the end of 1594³⁶¹ and reconstructed in 1988 and the Anatomical Theatre of the Archiginnasio in Bologna built in 1638³⁶². They were built in various sizes, forms and layouts. An entire building or a room in a building was devoted to the anatomical theatre. The essentials of the anatomical theatre were a dissection table placed in the center of the space and seating or standing areas, usually tiers with railings surrounding the table. Circular, semicircular, elliptic, or octagonal forms were used for the anatomical theatres which were considered to be ideal for viewing a spectacle taking place in the center. The most common one was amphitheatrical form, following the Greek and Roman theatre architecture tradition. To better understand the architectural features and the spatial quality of the anatomical theatres, it is necessary to analyze them within the broader context of theatre architecture.

³⁶¹ Huisman, "The Finger of God: Anatomical Practice in 17th-Century Leiden." 10

³⁶² Ferrari, "Public Anatomy Lessons and the Carnival: The Anatomy Theatre of Bologna."50

Theatre refers to a specialized category of buildings designed for public gathering or performance. Historically, there are two main types of open-air theatres, which are “theatre” and “amphitheater”.³⁶³ The “theatre” has a semi-circular form and it was used both by Greeks and Romans mainly for theatre plays. On the other hand, the “amphitheater” has circular or elliptical form, as *amphi* means from both sides in order to see from all directions and has an arena in the center. Unlike “theatre”, “amphitheater” was only used by Romans, for gladiator and wild animal fights. In general, the Greek, Hellenistic, and Roman open air theatre was composed of three elements. The first one is the *cavea* or *theatron* which was the area dedicated for the audience. The second one was the *orchestra* that was in front of the *cavea* and partially surrounded by it. The third one was the *skene* that referred to the theatre building behind *the orchestra*.³⁶⁴

In addition to these two, a comparatively smaller but still specialized type of theatre building was developed simultaneously with the larger outdoor theatres. It was identified by the generic Latin term *theatrum tectum* (roofed theatre) or referred to as *odeon*. The audience seated in a semicircular arrangement similar to that of the “theatre”. This type was emerged in the Greek period and became widespread in the Roman period and used for music performance or large-scale meetings.³⁶⁵

At this point it is essential to mention the work of Roman architect and engineer Vitruvius, who lived in the 1st century B.C., on theatre architecture. In the fifth book of his masterpiece, *De Architectura* (c.27-23 BC) which was basically a handbook for Roman architects, he discussed the construction, proportions, orientation and acoustical aspects of the Greek and Roman theatres and defined the principles for designing a theatre of the Greek and Roman type.³⁶⁶

³⁶³ Jens Holger Rindel, “Roman Theatres and Revival of Their Acoustics in the ERATO Project,” *Acta Acustica United with Acustica* 99, no. 1 (2013): 21–29, <https://doi.org/10.3813/AAA.918584>.

³⁶⁴ Donald Struan Robertson, *Greek and Roman Architecture* (Cambridge: Cambridge University Press, 1969). 271

³⁶⁵ Naif Haddad and Talal Akasheh, “Vitruvius and Ancient Theatres,” in *ERATO Project Symposium Proceedings*, 2006.

³⁶⁶ Frank B. Sear, “Vitruvius and Roman Theatre Design,” *American Journal of Archaeology* 94, no. 2 (1990): 249–58, <http://www.jstor.org/stable/505952>. 249

It is important to underline the fact that Vitruvius mentioned neither the amphitheater, as it was a later invention, nor the *odeon*, as it had not been yet a tradition.³⁶⁷ Therefore, his analysis of the Greek and Roman theatre was confined to the semicircular model.

According to Vitruvius, the geometrical layout of both the Greek theatre and Roman theatre is established according to the relationship between the *orchestra* and the *cavea*. In Greek theatre, the angles of three rotated squares touching the circumference organize the scheme, while in Roman theatre the angles of four rotated triangles shape the layout.³⁶⁸ (Fig. 83-84)

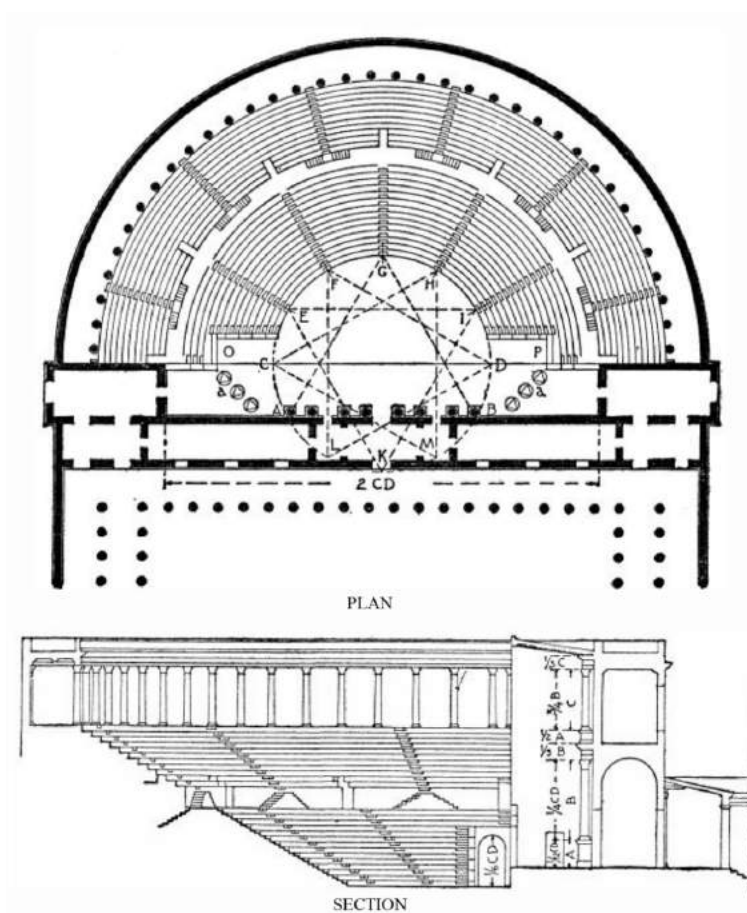

Figure 83. Roman theatre according to Vitruvius

Source: Vitruvius, *Ten Books on Architecture* (Cambridge: Harvard University Press, 1914).

³⁶⁷ Haddad and Akasheh, "Vitruvius and Ancient Theatres."

³⁶⁸ Vitruvius, *Ten Books on Architecture* (Cambridge: Harvard University Press, 1914).

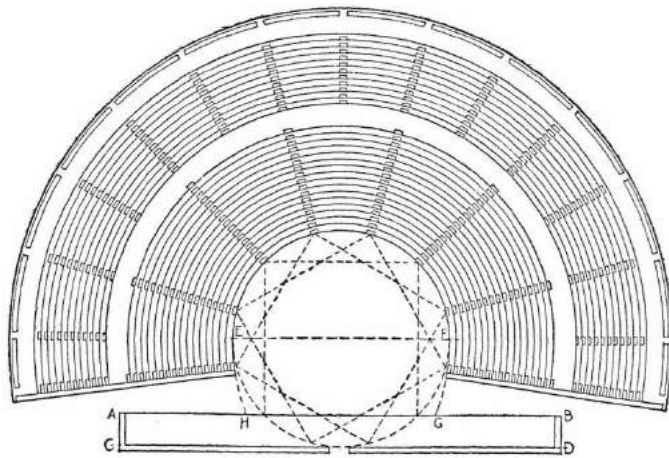

Figure 84. Greek theatre according to Vitruvius

Source: Vitruvius, *Ten Books on Architecture* (Cambridge: Harvard University Press, 1914).

In the light of this concise review of ancient theatre architecture, the emergence and development of the anatomical theatre as a distinct type of building, or part of a building, could be closely examined. The preliminary design idea of an anatomical auditory was brought by the anatomist and surgeon Alexander Benedictus, or Alessandro Benedetti (1450?–1512), from Padua. In his book *Anatomia sive Historia Corporis Humani*, published in 1493, he described “the ideal space for anatomical demonstrations.” According to his description, the anatomical demonstration hall should have a large auditorium for an adequate number of visitors to observe the dissection. The audience should be arranged in a circular manner to ensure good visibility. There should be a well illuminated dissection table in the center.³⁶⁹ His proposal also mentioned sufficient ventilation, two guards for protection and the collection of an admission fee.³⁷⁰ An important point is that Benedictus wrote that this ideal building for anatomical dissections was similar to the ancient Roman theatre or arenas, such as the Colosseum or the Arena in Verona.³⁷¹ In that period, theatres were known as Colosseums, consequently the ideal space for the

³⁶⁹ Huisman, “The Finger of God: Anatomical Practice in 17th-Century Leiden.” 27

³⁷⁰ Schumacher, “Theatrum Anatomicum in History and Today.” 18

³⁷¹ Huisman, “The Finger of God: Anatomical Practice in 17th-Century Leiden.” 28

demonstration of anatomical dissections were imagined as Colosseums. The engraving accompanied a number of Venetian editions of Latin plays at the end of the fifteenth and beginning of the sixteenth centuries included the caption "*Coliseus sive theatrum*", meaning colosseum or theatre. (Fig.85) Giovanna Ferrari mentions that this engraving inspired the design of the frontispiece of *De humani corporis fabrica* of Vesalius.^{372 373} (Fig.107) Another architectural proposal was introduced by Carolus Stephanus. He described a wooden structure with ascending semicircular seats, spacious enough to accommodate 500 people.³⁷⁴ (Fig.86) The influence of both designs could be seen in prominent anatomical theatres that were built in sixteenth and seventeenth centuries.

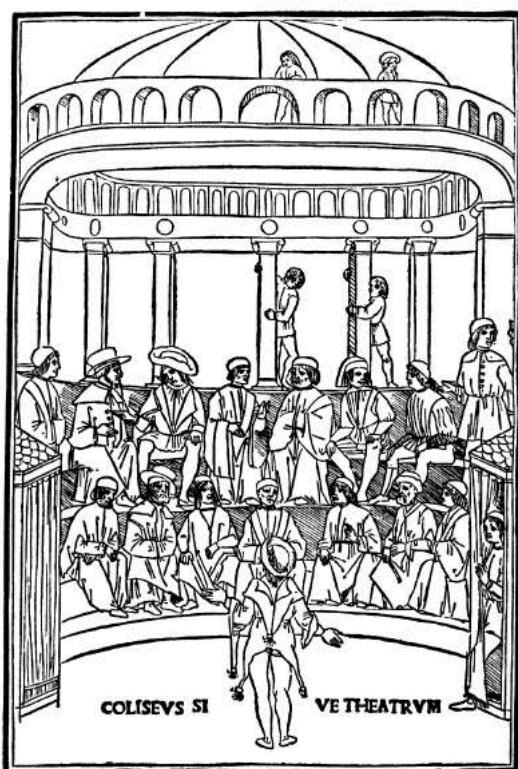

Figure 85. Engraving inserted in Plautus, *Comodiae XX*, Venice, 1511

Source: Giovanna Ferrari, "Public Anatomy Lessons and the Carnival: The Anatomy Theatre of Bologna," *The Past and Present Society*, no. 117 (1987): 50–106, <http://www.jstor.org/stable/650788>, 67

³⁷² Ferrari, "Public Anatomy Lessons and the Carnival: The Anatomy Theatre of Bologna." 84

³⁷³ The frontispiece of *De humani corporis fabrica* by Vesalius is elaborately discussed in Chapter 3.3.2.

³⁷⁴ Schumacher, "Theatrum Anatomicum in History and Today."18

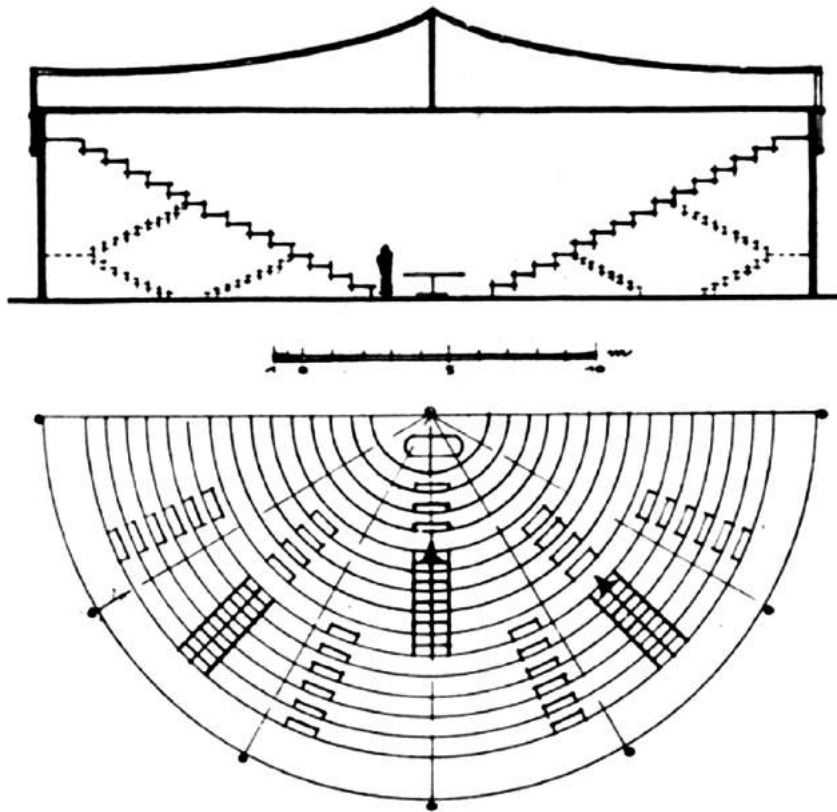

Figure 86. Architectural design of an anatomical theatre from Carolus Stephanus, in his book “De dissectione partium corporis”, Paris 1546.

Source: Gert Horst Schumacher, “Theatrum Anatomicum in History and Today,” *International Journal of Morphology* 25, no. 1 (2007): 15–32, <https://doi.org/10.4067/S0717-95022007000100002>, 18

An alternative semicircular model was proposed by the renowned French anatomist Charles Estienne (1504-1564). In his textbook of theoretical practical anatomy, *De dissectione partium corporis humani* published in 1545, he included an explicit description of an “ideal Vitruvian-style anatomy theatre” and the instructions regarding how the public anatomy lessons should be conducted. He highlighted the importance of the “place” of anatomical teaching and stated that a proper anatomical education cannot not be achieved if there is no adequate *locus anatomicus* (anatomical site) designed for that purpose.³⁷⁵ Regarding the perspective of Estienne on the subject, Ferrari wrote:

³⁷⁵ Ferrari, “Public Anatomy Lessons and the Carnival: The Anatomy Theatre of Bologna.” 85

“Estienne said that anatomy was comparable to any public show, and a dissected human body to ‘anything that exhibited in a theatre in order to be viewed’, ...which, he wrote, appears a great deal beautiful and pleasing to the spectators if they are able to clearly, from equally good vantage points, and without getting another’s way.”³⁷⁶

While describing the ideal anatomical theatre, Estienne used the relevant terminology. He mentioned the terms *cavea*, *hemicyclus* and *scena*. He also studied the details such as the seating measurements, entrance and exits for each part of the theatre. According to Ferrari, the deep knowledge of Estienne on theatre architecture pointed out that he either knew about *De architectura* of Vitruvius or worked with someone who did.³⁷⁷

Before the permanent buildings for public dissections were built, temporary structures had been used for this purpose. By the 16th century, with the flourishing public interest towards anatomy, the first temporary structures to accommodate anatomical dissections were erected in Italy that transformed the scholarly concept of dissection into a public performance with a strict ritual. Based on the ideas introduced by Benedictus and under the influence of the ancient theatres in Rome and Verona, the building named as “*theatrum anatomicum*” appeared. These temporary anatomical theatres were kiosk-like wooden structures, constructed when needed and then dismantled each year after the dissection was over. They were well-ventilated spaces with seats around the central dissection table, and their size was adjustable. As seen in the illustrations from early sixteenth century, the temporary anatomical theatre was spatially and conceptually organized in three levels. The upper level was for the professor to stand and guide the dissection by teaching from books. On the level below, the instructor transmitted the findings of the dissection to the professor and his comments to the students. At the bottom there lay the cadaver on a table, dissected by a barber-surgeon surrounded by students.³⁷⁸ (Fig.87-88)

³⁷⁶ Charles Estienne, *De dissectione partium corporis humani libri tres* (Paris, 1545) in Ferrari. 85

³⁷⁷ Estienne in Ferrari. 85

³⁷⁸ Schumacher, “Theatrum Anatomicum in History and Today.”19



Figure 87. Theatrum anatomicum temporarium. a. Woodcut illustration of the book *Anatomia Mundini*, Rostock, University Library ed. 1513. in G. H. Schumacher and H.-G. Wischhusen 1970.

Source: Gert Horst Schumacher, "Theatrum Anatomicum in History and Today," *International Journal of Morphology* 25, no. 1 (2007): 15–32, 19



Figure 88. Woodcut illustration, *Anatomie de Mondin* Paris, A. Lotrian et D. Janot 1532.

Source: Schumacher, 19

In the second half of the sixteenth century, the progress in the field of anatomy engendered the construction of permanent anatomical theatres. During the 16th and 17th centuries, two different designs were adopted, the Padua type and the Bologna type. Although having different architectural qualities, they were both wooden structures built into a tall university building.³⁷⁹

³⁷⁹ Schumacher.20

Towards the end of the sixteenth century, Padua became a city well-known with the anatomical advancements. Padua University was the center of anatomical scholarship in Europe. The cutting-edge science of that period was dissection, therefore the first permanent anatomical theatre designed by Fabricius ab Aquapendente (1537-1617) was constructed in Padua in 1594 and served as a model for many anatomical theatres built afterwards in Leiden (1594-7), Groningen (1654/5), Copenhagen (1640-3), Upsala (1662), Amsterdam (1691), Altdorf (1650), Halle (1727) and Berlin (1720).³⁸⁰

The wooden anatomical theatre was located in the fourteenth century edifice Bo Palace, the central building of the University of Padua and had been used for public dissections 278 years before it was converted to a museum in 1872. Today, the theatre still survives as a witness to history and can be visited as a museum.³⁸¹

The circular funnel shaped design of the anatomical theatre reminds the proposal of Benedictus and bears the traces of ancient Roman theatres or arenas having amphitheater form, such as the Colosseum or the Arena in Verona which were located nearby the city of Padua.³⁸² The theatre has a height of 12m that rises through two stories of the palace. It occupies an area of 8.75 x 10.0 m and comprises of six concentric ascending tiers, each with 0.92 m rise and surrounded by a carved balustrade. The auditorium is large enough to accommodate 200 people standing. At the focal point of the funnel, the dissection table is placed over a trapdoor, allowing it to be lowered for the purpose of disguising the cadaver when needed. Although the deep funnel form designed for an intense visual experience provided uninterrupted, good quality view for the audience, it had several downsides. The lacking of sufficient daylight caused the necessity for artificial lighting. Narrow rows caused difficulties in circulation. Located at the bottom of the steep funnel, the stage

³⁸⁰ Schumacher.20

³⁸¹ Alison Abbott, "Hidden Treasures: Padua's Anatomy Theatre," *Nature* 454 (2008), <https://doi.org/10.1038/454699a>. 699

³⁸² Huisman, "The Finger of God: Anatomical Practice in 17th-Century Leiden." 28

space devoted to dissection and demonstration was quite limited, barely leaving room for the professor, assistants and eight students holding the candles.³⁸³ (Fig. 89)

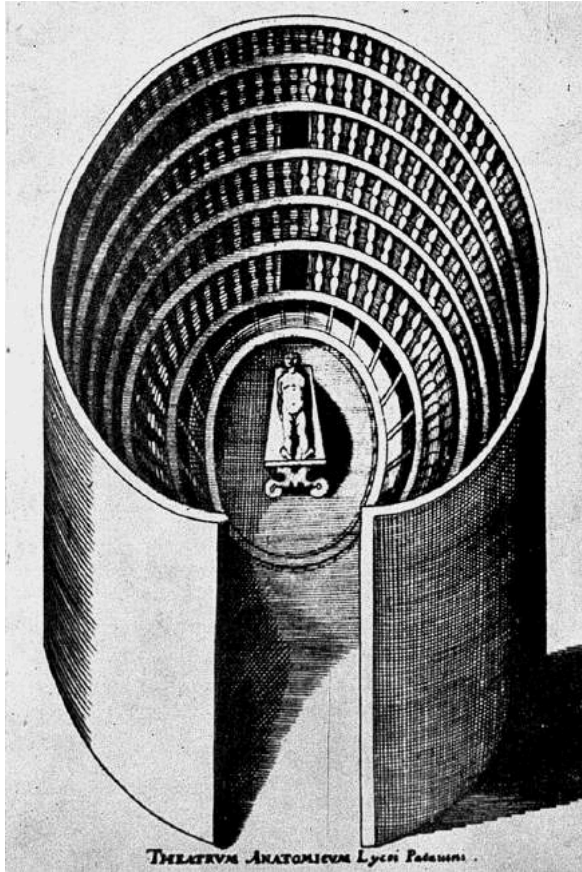

Figure 89. Copperplate engraving of the Anatomical theatre of Padua, 1654

Source: Gert Horst Schumacher, "Theatrum Anatomicum in History and Today," *International Journal of Morphology* 25, no. 1 (2007): 15–32, <https://doi.org/10.4067/S0717-95022007000100002>, 20

Leiden Anatomical Theatre was formally similar to the anatomical theatre of Padua. It was equipped with six concentric tiers, but unlike the ones in Padua they were less steep leaving the large windows unblocked, allowing daylight to enter and illuminate the entire space easily.³⁸⁴

³⁸³ Schumacher, "Theatrum Anatomicum in History and Today."20

³⁸⁴ Schumacher.21



Figure 90. Theatrum anatomicum in Leiden, c.1615.

Source: Gert Horst Schumacher, "Theatrum Anatomicum in History and Today," *International Journal of Morphology* 25, no. 1 (2007): 15–32, <https://doi.org/10.4067/S0717-95022007000100002>, 21

Another significant anatomical theatre is the theatrum anatomicum in Uppsala erected in 1620. It is considered to be an unusual example since it was built on the top of the main university building named Gustavianum. The copula with the sundial/sun globe on top was constructed in 1662 and became a distinctive quality of the building. Apart from enhancing the exterior appearance of the building, it provided the needed lighting to the anatomical theatre, solving the illumination problem which was quite innovative for its time. The funnel-like design of the theatre was similar to that of Padua but differently, it had octagonal tiers instead of circular.³⁸⁵

³⁸⁵ Schumacher.22

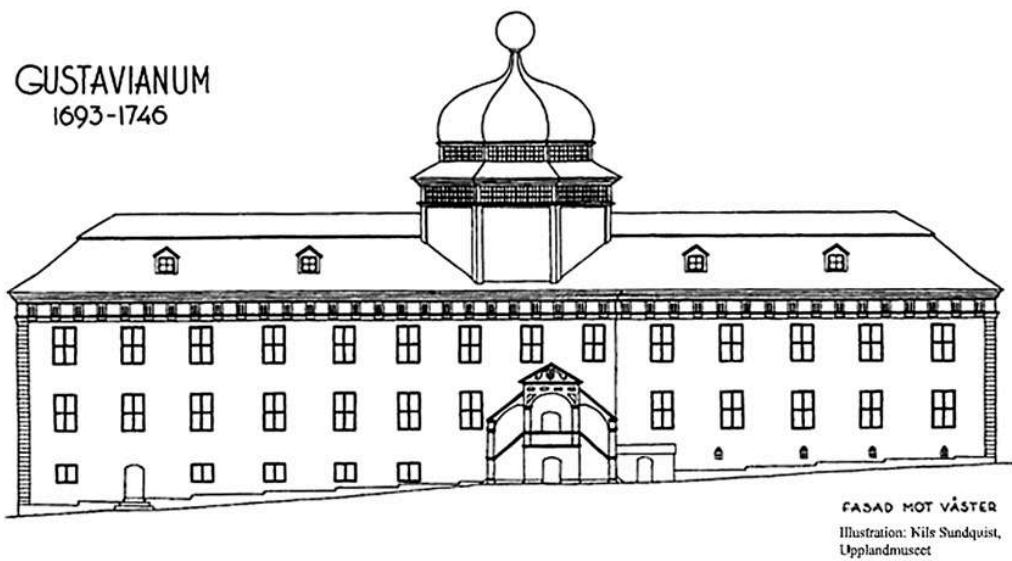

Figure 91. Drawing showing the front façade of the University building "Gustavianum" in Uppsala with the Theatrum anatomicum at the top by Nils Sundquist

Source: Gert Horst Schumacher, "Theatrum Anatomicum in History and Today," *International Journal of Morphology* 25, no. 1 (2007): 15–32, <https://doi.org/10.4067/S0717-95022007000100002>, 22



Figure 92. Interior of the anatomical theatre in Uppsala

Source: Chiara Mascardi and Emanuele Armocida, "The THESA Project - THEatre Science Anatomy," *Medicina Historica* 1, no. 3 (2017): 168–72. 170

The Bologna type emerged in Bologna in 1649 when a new notable chamber dedicated to anatomical dissections, so-called *Teatro Anatomico* (Anatomical Theatre) was built inside the Archiginnasio Palace, which used to be the main building of the ancient University of Bologna. The theatre was designed by Antonio Paolucci, known as Antonio Levanti, who was a student of the Carracci, a renowned Bolognese family of talented artists.³⁸⁶ The design of the Bologna Anatomical Theatre was quite different from the theatre of Padua. It was an ample room with rectangular rows for seating. It was decorated with elaborate wooden engravings, sculptures and inscriptions. It looked like a medieval meeting place more than an ancient theatre. Unlike the tight and steep circular rows of the Padua theatre which only allowed the audience to watch the dissections in standing position, the anatomical theatre of Bologna provided the visitors spacious and comfortable rows for seating.³⁸⁷ G. Richter, who systematically and meticulously studied the anatomical theatres explained the main difference between the theatre of Padua and Bologna as follows:

“...the two theatres - in Padua and in Bologna - serve quite different purposes: the former is a response to primarily functional demands, the latter to eminently "spectacular" ones.”³⁸⁸

The Anatomical Theatre of Bologna functioned for 154 years until it was converted to a museum in 1803. After getting damaged during the World War II, it was renovated and opened to visit again. The only other example of Bologna type anatomical theatres is the one in the University of Ferrara referred to as Anatomical Theatre “Giovanni Tumiatì” built in 1731, located on the ground floor of Palazzo Paradiso.³⁸⁹

³⁸⁶ Di Matteo et al., “Art In Science: The Stage of the Human Body—The Anatomical Theatre of Bologna.” 1874

³⁸⁷ Schumacher, “Theatrum Anatomicum in History and Today.”22

³⁸⁸G. Richter, *Das Anatomische Theater* (Berlin, 1936), pp. 55 referred to in Ferrari, “Public Anatomy Lessons and the Carnival: The Anatomy Theatre of Bologna.” 76

³⁸⁹ Schumacher, “Theatrum Anatomicum in History and Today.”22

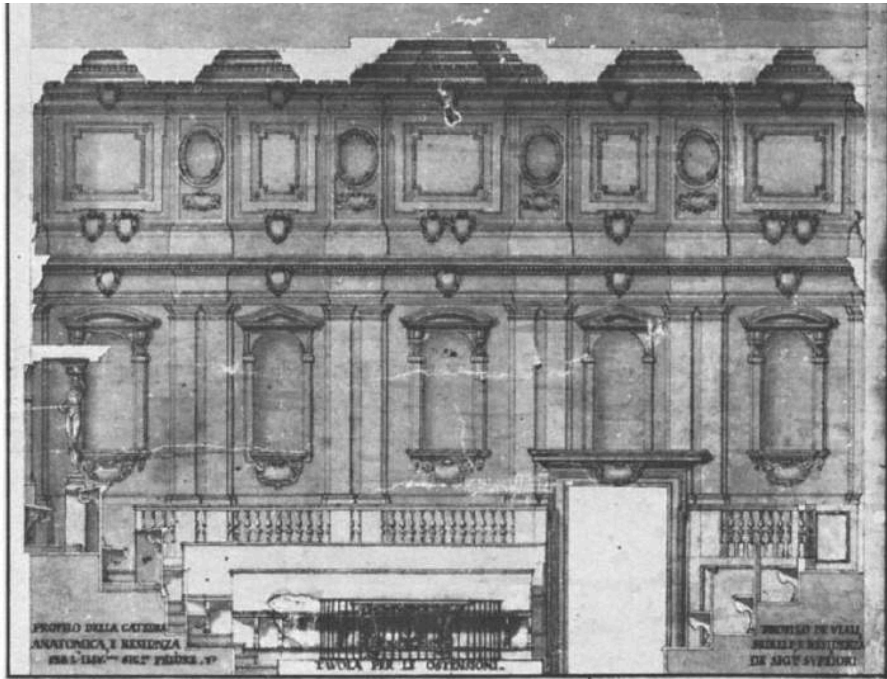

Figure 93. Longitudinal section of the Anatomical Theatre of Bologna

Source: Giovanna Ferrari, "Public Anatomy Lessons and the Carnival: The Anatomy Theatre of Bologna," *The Past and Present Society*, no. 117 (1987): 50–106, <http://www.jstor.org/stable/650788>, 83



Figure 94. Interior of the Anatomical Theatre of Bologna. Colors edited by the author.

Source: Gert Horst Schumacher, "Theatrum Anatomicum in History and Today," *International Journal of Morphology* 25, no. 1 (2007): 15–32, <https://doi.org/10.4067/S0717-95022007000100002>, 23

In the 18th century, due to the advancements in anatomical education, increasing number of medical students and the progress in building technologies, the existing anatomical buildings were modified and new buildings complying with the emergent requirements of the time were built. The Anatomical Theatre of the School of Surgery in Paris (*Le Grand Amphithéâtre des Ecoles de Chirurgie Paris*) erected in 1768-1775, is an important example regarding its large semi-dome ceiling with an oculus for adequate illumination and capacity of more than 1400 viewers. (Fig. 95) The spaciousness of the anatomical theatre in the School of Surgery was thought to be a positive feature, but in fact it provided a worse visual experience to the viewers compared to the cramped theatres of Padua and Uppsala. In the theatre of Paris School of Surgery, the cadaver and the demonstrations of the professor seemed extremely small and visually incomprehensible.³⁹⁰

The anatomical theatre carried the traces of antic theatre architecture and also resembled the roman Pantheon. Nevertheless, unlike Pantheon it had a semi-circular form recalling the design proposed by Estienne centuries ago. Interestingly enough, the semi-circular design was not preferred until the 18th century while the amphitheatrical model of Benedictus was highly used for over three centuries.³⁹¹ Today, the anatomical theatre of School of Surgeons in Paris is still in use as an assembly hall.

³⁹⁰ Schumacher.22

³⁹¹ Ferrari, "Public Anatomy Lessons and the Carnival: The Anatomy Theatre of Bologna." 86

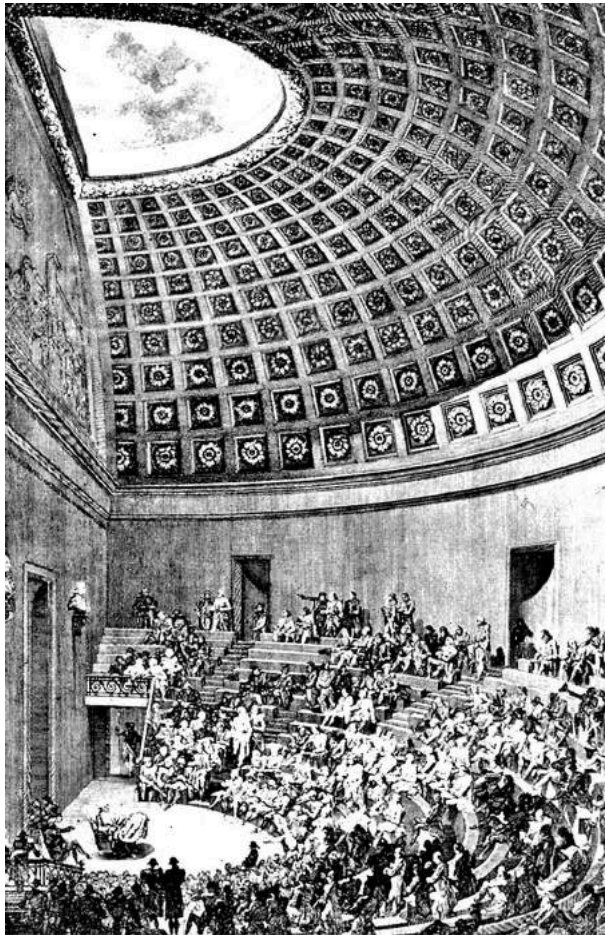

Figure 95. Le Grand Amphithéâtre des Ecoles de Chirurgie Paris. Copperplate engraving from Claude-René-Gabriel Poulleau, in: Gondoin, *Description des Ecoles de Chirurgie*, Paris 1780.

Source: Schumacher, "Theatrum Anatomicum in History and Today," 24

All these prominent examples show that the remarkable space of the anatomical theatre cannot be understood without knowing the origins of theatre architecture. Knowing the Greek and Roman theatres and the work of Vitruvius on them are essential to comprehend the architectural character of the anatomical theatres.

“W. S. Heckscher even argues that many general theatre techniques were originally designed with the performance of public anatomy lessons in mind. In Heckscher's view, the theatre itself - that is, the erection of a special building to accommodate performances - originated in the anatomy amphitheatre.”³⁹²

³⁹² Ferrari. 84

The powerful argument of the art historian Heckscher mentioned by Ferrari, claims that the anatomical theatre, as a matter of fact, is the source of the idea of an enclosed building devoted to the spectacles to take place, shortly the modern concept of a theatre. Apart from sharing the same origin, or one being the origin of the other, the anatomical theatre and the theatre developed as distinct but highly related concepts for centuries. Ferrari wrote on the subject as follows:

“One might add that even if the two different types of theatrical "performance" became increasingly distinct with the passage of time, historians of the theatre should perhaps bear in mind the fact that the two kinds of architectural structure (the anatomy theatre and the theatre proper) for centuries led a parallel existence.”³⁹³

The peculiar case of the Bibiena Scientific Theatre in Mantua, Italy built in 1767-1769, epitomizes this argument. The theatre was designed by the architect Antonio Bibiena to accommodate both musical, theatrical events and scientific spectacular demonstrations. While the bell-shaped plan of the theatre was for enhancing the theatrical function, the gallery planned behind the stage, an auditorium that seemed like an amphitheater, was for scientific spectacles.³⁹⁴

“In actual fact, during the eighteenth century, not only were operas and musical dramas staged in that particular theatre, but exercises in anatomy and surgery, carried out by the medical surgical department of the academy that owned the theatre, also place there, as did experiments in physics and chemistry.”³⁹⁵

This proves that the relationship between the anatomical theatre and the “theatre proper” was not just on a conceptual basis but also in spatial terms. These two theatrical concepts, developing in parallel, had merged in some special cases such as the Bibiena Scientific Theatre, by means of sharing the very same space. Today, the

³⁹³ Ferrari. 87

³⁹⁴ G. Ricci, *Teatri d'Italia dalla Magna Grecia all'Ottocento* (Milan, 1971), 162-5; E. Marani, *Il teatro di Antonio Bibiena in Mantova e il Palazzo accademico* (Mantua, 1979), 12-19 referred to in Ferrari. 87

³⁹⁵ U. Tibaldi, "Il teatro scientifico in Mantova" (duplicated paper, Ente provinciale del Turismo di Mantova, n.d.) in Ferrari. 87

Bibiena Theatre is still used to host both theatrical events, concerts and scientific conferences.



Figure 96. Bibiena Scientific Theatre, Mantua

Source: Chiara Mascardi and Emanuele Armocida, “The THESA Project - THEatre Science Anatomy,” *Medicina Historica* 1, no. 3 (2017): 168–72. 170

3.2.4. Ocular Anatomy and Ocular Space

“The relationship between seeing and knowing becomes stronger and more complex as seeing emerges as the strongest and the most judgemental sense.”³⁹⁶

The word theatre comes from the Ancient Greek θέατρον (*théatron*), “a place for viewing,” that is originated from θεάομαι (*theáomai*), “to see”, “to watch”, “to observe.” As the etymology of the word indicates, theatres are spaces that are created

³⁹⁶ Donald M. Lowe, *History of Bourgeois Perception* (Brighton: Harvester Press, 1982). quoted in Hooper-Greenhill, *Museums and the Shaping of Knowledge*. 86

for the act of “seeing.” The two major activities hosted by the theatre are “(dis)playing” and “watching” that refer to the delivery of something to be seen and the reception of it, respectively. Although hearing is also an important sense stimulated in the theatre, the activities fundamentally revolve around the concept of “seeing.” This means that the space of the theatre is sight-oriented and rely on the sovereignty of vision. Within this context, theatre design strives to ensure the best visual experience. Ascending tiers, agonic forms, central positioning of the stage... All these architectural features are the apparent outcomes of the great endeavor for providing good visibility to the audience. In better terms, the primary goal of achieving a visuality of the best quality is realized through the possibilities offered by the architecture.

Considering that theatres are spaces designed for the functioning of the eye, Pannill Camp reveals the relationship between the development of theatre architecture and the discovery of ocular anatomy. According to Camp, “theatre buildings adopted a shape determined not just by the usual concerns of audibility and visibility, but also by the geometry of vision itself — that of the eye.”³⁹⁷ He builds his argument based on the fact that theatre being a space of attaining and disseminating knowledge and theatre architecture being a “mode of thought.”³⁹⁸

Theatre is associated with the act of “seeing,” but not in a basic sense. To put it more accurately, it is about “knowing by seeing.” In the space of the theatre, the eye itself becomes an apparatus of knowing. Theatre architecture “reflects an underlying condition of knowing, or *connaissance*³⁹⁹, that is itself conditioned by history.”⁴⁰⁰ At this point, it becomes necessary to recall the unfinished, yet highly influential project of Giulio Camillo, The Memory Theatre, from the early sixteenth century. The Theatre of Camillo suggests significance in this context, since it is the most

³⁹⁷ Pannill Camp, “Ocular Anatomy, Chiasm, and Theatre Architecture as a Material Phenomenology in Early Modern Europe,” in *Anatomy Live: Performance and the Operating Theatre*, ed. Maaïke Bleeker (Amsterdam: Amsterdam University Press, 2008), 129–46. 144

³⁹⁸ Camp. 129

³⁹⁹ Foucault, *The Order of Things: An Archeology of the Human Sciences*.

⁴⁰⁰ Camp, “Ocular Anatomy, Chiasm, and Theatre Architecture as a Material Phenomenology in Early Modern Europe.” 129

evident example of a theatre, materializing the abstract and complex correlation between seeing and knowing. On this subject, Camp wrote:

“That is to say that Camillo’s theatre is the embodiment of a seeing whose station and peculiar form is to produce an adequate knowing – in its materiality it is thought to manifest knowledge itself; the corporeal looking in the form of the theatre...”⁴⁰¹

Another Renaissance invention, the anatomical theatre, is also a concrete example showing the links between the theatre form, sight, and knowledge. For the place that would accommodate the demonstrations of anatomical dissections, theatre form was chosen. Round stages surrounded by gradually ascending tiers enabled the audience to “literally gaze into the cadaver from a high angle.”⁴⁰² The curious eyes filled with the lust for learning and the desire to know the human anatomy were pleased thanks to the virtues of theatre architecture that enhance the relationship between seeing and knowing. As expressed by Manuela Infante-Guell:

“Visibility promises knowledge about that which previously remained unintelligible, obscure or hidden. This is the promise also presented by the anatomical theatre: namely, that ocular experience corresponds directly to knowledge about the human body and maybe even about the mysteries of the human soul. To see is to know.”⁴⁰³

In addition, to this rather obvious relation established between anatomical knowledge, vision and theatre, Camp reveals another context associating these concepts on a whole different level. After tracking down the historical paths of theatre architecture and ocular anatomy, he discovered seminal isomorphisms and isofunctionalities between the theatre space and the eye. He explains his thesis as follows:

“Western theatre architecture developed contemporaneously with the rationalization of ocular anatomy to geometric optics from the seventeenth

⁴⁰¹ Camp. 133

⁴⁰² Djck, “Digital Cadavers and Virtual Dissection.” 39

⁴⁰³ Manuela Infante-Guell, “Performance Documentation 8: Körper,” in *Anatomy Live: Performance and the Operating Theatre* (Amsterdam University Press, 2008), 245–49. 246

century onwards, and there is reason to believe that the morphology of both types of structure manifests a grand, diffuse reorientation of mankind's relationship to the world. As vision, constituted in the emerging understanding of the eye's function, came to be a central figure for man's relationship to other things (which is to say, objectivity), theatre buildings came to model this same relationship and to embody an isomorphism with ocular anatomy."⁴⁰⁴

As stated by Camp, Teatro Farnese in Parma designed by Giovanni Battista Aleotti and completed in 1618 is considered to be the archetype of modern theatre. (Fig. 97) The construction of this theatre practically coincided with the optical treatise written by the physicist Christoph Scheiner named *Oculus, Hoc Est: Fundamentum opticum*, known to be the first accurate description of the anatomy of the eye, published in Innsbruck, in 1619. This means that the time period corresponding to years 1618-1619 was significant for both the history of theatre architecture and the history of ocular science in terms of indicating their transition to the modern age. The concurrent occurrence of these two critical events suggests a peculiar relationship despite the long distance between them. As expected, this relationship was not momentary, instead it was a reflection of a complex network of ideas and actions built over the centuries.⁴⁰⁵

⁴⁰⁴ Camp, "Ocular Anatomy, Chiasm, and Theatre Architecture as a Material Phenomenology in Early Modern Europe." 133

⁴⁰⁵ Camp.133



Figure 97. Photograph showing the interior of Teatro Farnese

Source: “Giovanna D’Arco by Saskia Boddeke and Peter Greenaway,” accessed July 8, 2020, <https://www.sbspj-projects.com/blog/tag/Teatro+Farnese>.

Vision was a dominant concept in Renaissance, giving rise to scientific developments focusing on the better understanding of the vision-related fields that were in principle optics and ocular anatomy. These advancements deeply influenced the architectural theory and practice, especially the theatre architecture. The Renaissance theatre, that was characterized with the revival and reinterpretation of Vitruvian theatre, was a reflection of the advanced conception of the anatomical structure of the eye and its functioning. In addition, perspective, discovered in the late fifteenth century and elaborated in the sixteenth century, was incorporated into theatre architecture, and conveyed as an ocular concept. Constructed decades before Teatro Farnese, Accademia Olimpica in Vicenza designed by Andrea Palladio and completed in 1580 sets a good example in terms of epitomizing the interactions between ocular science and theatre architecture. Within this context, Camp wrote:

“The coincidence of a reinvigoration of theatre design, the sundry perspective techniques in the visual arts, a proliferation of human anatomical knowledge

and the rectification thereof with a refined understanding of light and optics produced a series of buildings that manifest clear isomorphic resonances with the human eye. In particular, the chiasmic confrontation with respect to sightlines between stage and auditorium was articulated quite early by Andrea Palladio.”⁴⁰⁶

Accademia Olimpico was and still is an outstanding theatre building in many aspects. Its scenic enhancements manifest the Renaissance desire for the embodied practices of vision. The design of its stage and auditorium portray a remarkable adaptation of Vitruvian theatre. (Fig. 98) More importantly, the deep scenic complex beyond the *scenae frons* marks Teatro Olimpico as a daring approach and powerful statement in the history of Western theatre architecture tradition. In fact, the element characterizing the theatre, the *trompe-l'œil* onstage scenery depicting seven perspective street scenes was added to the *scenae frons* four years after Palladio's death by Vincenzo Scamozzi and Palladio's son Silla.(Fig.99) These scenic constructions were enhanced with a dome painted as the sky, following the methods of constructing perspective scenery described by Sebastiano Serlio in his book *De architettura* (1545). The perspective street scenes were not converging in Serlian fashion, instead their axes were smartly arranged so that at least one street is visible to each viewer. Camp described the perspective scenic construction of Teatro Olimpico as follows:

“...when seen in plan, reveals a crossing of sightlines from the outermost ranges of the auditorium over each other down opposing street perspectives. Five of the seven streets converge at the intersection of the proscenium threshold with the sagittal plane of the theatre, creating a ‘nodal point’ suggestive of the reference point in ocular anatomy from which light rays seem to originate as they travel to the light receptors in the retina.”⁴⁰⁷

⁴⁰⁶ Camp.130

⁴⁰⁷ Camp.134

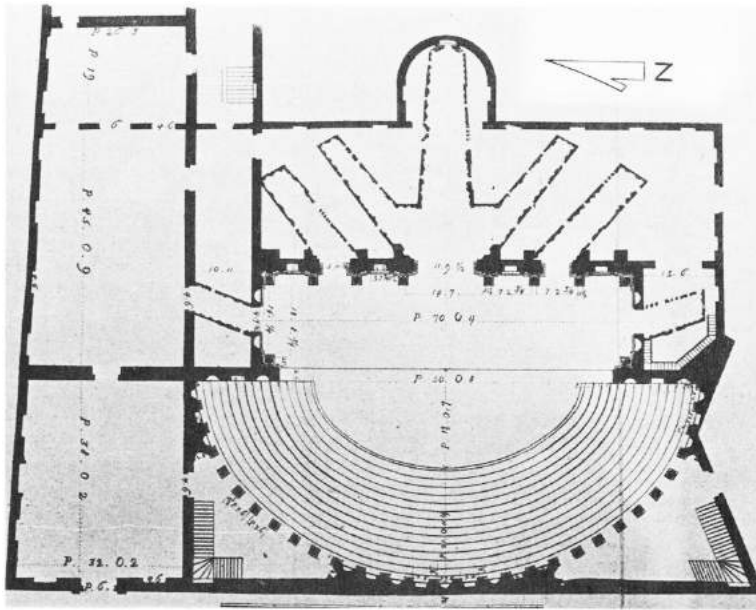

Figure 98. The floor plan drawing of Teatro Olimpico. Colors edited by the author.

Source: J. Thomas Oosting, "The Teatro Olimpico Design Sources : A Rationale for the Elliptical Auditorium," *Educational Theatre Journal* 22, no. 3 (1970): 256–67, <http://www.jstor.com/stable/3205532>, 262



Figure 99. Photograph showing the perspective scenery on Scaenae frons of Teatro Olimpico, by Terry Clinton

Source: Javier Berzal de Dios, "Palladio, Teatro Olimpico," Khan Academy, accessed July 8, 2020, <https://www.khanacademy.org/humanities/renaissance-reformation/high-ren-florence-rome/late-renaissance-venice/a/palladio-teatro-olimpico>.

Although Camp establishes a similarity between the multiple-vista scenery of the theatre and the way light rays are absorbed by the light receptors in the retina of the eye, he underlines the fact that there is no clear evidence showing any concern towards introducing a biomorphic approach to the design of the theatre. It is likely that the shared motivation of Andrea Palladio, Silla Palladio and Vincenzo Scamozzi was basically implementing the optical conventions of perspective in an advanced manner. Yet, James S. Ackerman mentioned Palladio's interest in the human anatomy and its relation to architecture as he was known as an architect whose designs were guided by the physical and psychological formation of the human body. Ackerman also indicated the impact of Andreas Vesalius's broadly disseminated anatomical drawings, as he was practicing in Padua during Palladio's youth.⁴⁰⁸

At this point, it is necessary to mention the concept of "chiasm". The basic meaning of chiasm is the intersection or crossing of positional terms over each other in space in the form of the letter X. In the context of optics, chiasm refers to the X-shaped structure in brain formed by the crossing of the optic nerves, connecting the brain to the eyes.⁴⁰⁹ (Fig.100-101) The 1604 publication of Kepler, *Optics*, is considered to be the first modern approach to optics, presenting a clear understanding of the functioning of the eye. The work of Kepler together with the treatise of Scheiner dated 1619 "demonstrate a detailed and intimate mapping and analysis of the eyeball as an entity with mechanical and optical features whose function allows for the manipulation of light."⁴¹⁰(Fig. 102-103) The optical and anatomical drawings of both Kepler and Scheiner focus on "chiasm", demonstrating the crossing of light rays from an image over each other at the pupil like the camera obscura and the intersection of the lines that extend from the outer surface of the eye to the objects at distance.⁴¹¹ Camp relates the perspective scenery of Teatro Olimpico to the

⁴⁰⁸ James S. Ackerman, *Palladio* (Harmondsworth: Penguin Books, 1966). quoted in Dijck, "Digital Cadavers and Virtual Dissection." 135

⁴⁰⁹ Matz Larsson, "The Optic Chiasm: A Turning Point in the Evolution of Eye/Hand Coordinatin," *Frontiers in Zoology* 10, no. 1 (2013): 1–12.

⁴¹⁰ Camp, "Ocular Anatomy, Chiasm, and Theatre Architecture as a Material Phenomenology in Early Modern Europe."135

⁴¹¹ Camp.135

concept of “chiasm”. Accordingly, he explains the chiasmatic relations in the theatre as follows:

“The crossing over of sightlines from the outer edges of the auditorium and the frontal encounter between spectator and spectacle determine a seam along the proscenium edge that is chiasmatically coded. In the theatre one speaks of ‘stage right’ interchangeably with ‘house left’ in reference to the point of view of actor or audience, respectively. The persistence of this terminology in fact necessarily implies the dominance of the architectural convention of bilateral symmetry, upon which depends the fact of a constant, clear ‘right’ and ‘left’. In other words, the chiasm of sightlines made evident in the Teatro Olimpico marks the crossing over of a certain flat threshold, an instrumental perpendicular plane articulated and enforced by the architect’s volition.”⁴¹²

In Teatro Olimpico, the perspective street scenes establishes a chiasmatic link with the audience. The audience sitting on the leftmost side sees the rightmost street perspective, and concordantly, the viewers sitting on the rightmost side see the leftmost street perspective. This reverse matching of the audience with the scenic constructions reminds the optic chiasm and in this context, the proscenium edge corresponds to the junction point of the crossed bundle of the sightlines.

The concept of “proscenium arch”⁴¹³ referring to the arch form framing the proscenium plane was first used in Teatro Farnese in Parma by the architect Giovanni Battista Aleotti. It is believed that the central arch in the *scenae frons* of Teatro Olimpico foreshadowed the proscenium arch.⁴¹⁴ The invention of this architectural element corresponded to a time when the studies in optics, ocular anatomy, astronomy were proliferated, therefore became the symbolic form of “seeing” in Renaissance theatre.

⁴¹² Camp.134

⁴¹³ The Latin word *proscenium*, began to be used in the early 17th century, comes from Greek *proskēnion*, from *pro* ‘before’ + *skēnē* ‘stage’. In ancient Greek theatres, the word originally referred to a narrow and raised division of the stage where solo actors performed. Later, the term corresponded to the opening or imaginary vertical plane separating the stage from the audience.

⁴¹⁴ Camp, “Ocular Anatomy, Chiasm, and Theatre Architecture as a Material Phenomenology in Early Modern Europe.”¹³⁵

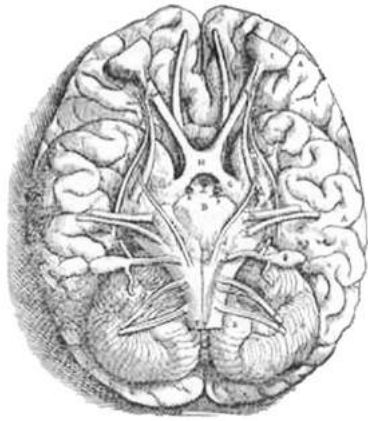

Figure 100. Illustration from *De humani corporis fabrica* by Andreas Vesalius, 1543 showing the optic chiasm. Colors edited by the author.

Source: Claudia Florida Costea et al., "The History of Optic Chiasm from Antiquity to the Twentieth Century," *Child's Nervous System* 33, no. 11 (2017): 1889–98, 1893



Figure 101. Illustration showing the optic chiasm by Isaac Newton, 1704

Source: Costea et al., 1894

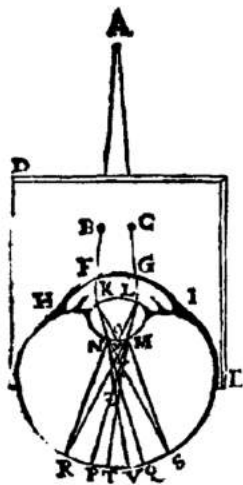

Figure 102. Scheiner's illustration of viewing a point through two pinholes (Scheiner's experiment).

Source: Nicholas J. Wade, "Image, Eye, and Retina (Invited Review)," *Journal of the Optical Society of America A* 24, no. 5 (2007): 1229–49, 1231

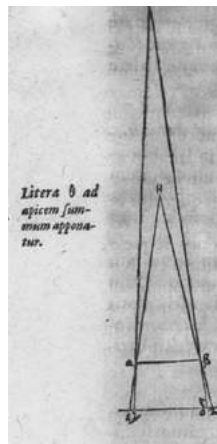

Figure 103. Diagram illustrating the relationship between the distance of a visible object and the breadth of the visual rays cast onto the back of the eye from Johannes Kepler, *Ad vitellionem paralipomena* (1604).

Source: Pannill Camp. "Ocular Anatomy, Chiasm, and Theatre Architecture as a Material Phenomenology in Early Modern Europe." *Anatomy live: Performance and the Operating Theatre* (2008): 129-46, 136

The optical studies of Johannes Kepler and Christoph Scheiner in the early 17th century suggested other relationships between the ocular anatomy and theatre architecture. Camp argues that the geometric forms constituting the structure of the eye described by Kepler and Scheiner were seen in the architectural plans of the theatre buildings built later on. Camp explained his argument as follows:

“For Kepler, the hemispheric surface of the eye’s interior, that anatomical contour itself — that is, its geometric form — exists in ratio not to the world itself, but to the contour of its appearance. The geometry used by Kepler and Scheiner to describe these appearances speaks to a repertoire shared with the geometry of Renaissance theatre architecture. Acute angles intersect circles symmetrically at their outermost points, or else cross over within them. Chiasm is a ubiquitous figure throughout. The hemispheric shape, common to Vitruvius, Camillo, Palladio, Kepler and Scheiner, is inevitably affixed to pairs of lines that cross each other, designating sightlines, either in the theatrical sense or in the sense of lines etched to model the passage of light rays through the body’s own orbits.”⁴¹⁵

Kepler’s implicit interest towards architecture, which could be traced in his writings, supports the arguments of Camp. While explaining the phenomena of vision, Kepler uses architectural analogy by saying that “genuine vision occurs when the folding door (*valvae*) or pupil of the eye is exposed most closely to the arriving ray of light.”⁴¹⁶ As Camp argues, Kepler’s choice of the Latin word *valvae*, a large double door found in buildings like temple or palace, leading to the conception of the eyeball as a chamber shows his understanding relating the ocular anatomy to architecture. For Kepler the geometric form of the eye suggested a macrocosm-microcosm relationship between the world and the human body. He wrote as follows:

“But this visible world is itself concave and round, and whatever we behold of the hemisphere or the greater with a single fixed gaze, is a part of this roundness. It is therefore fitting that the ratio of general objects to the whole

⁴¹⁵ Camp.138

⁴¹⁶ Johannes Kepler and William H. Donahue (trans.), *Optics: Paralipomena to Witelo & Optical Part of Astronomy* (Santa Fe: Green Lion Press, 2000). quoted in Camp, “Ocular Anatomy, Chiasm, and Theatre Architecture as a Material Phenomenology in Early Modern Europe.”136

hemisphere be estimated by the sense of vision, in the ratio of the entering form to the hemisphere of the eye.”⁴¹⁷

The theatre building designed by Claude-Nicolas Ledoux known as *Théâtre de Besançon* or Ledoux’s Theatre (1784) embodies the geometrical affinities between theatre architecture and the ocular anatomy. The round proscenium arch of the theatre that “gapes across the building, spanning the width of the second tier of boxes, and vaults up in roughly semi-circular fashion, mimicking the curvature of the iris partially covered by the upper eyelid”⁴¹⁸ is the most evident element epitomizing this argument. (Fig.104-105) The engraving of Ledoux included in his *L’architecture considérée sous le rapport de l’art, des moeurs et de la législation* published in 1804, proves Ledoux’s interest in relating the theatre design with the anatomical structure of the eye.(Fig.106) In the illustration, an eye seeing the interior of a theatre, whose form is spherical, similar to the eyeball, is depicted. The isomorphism of the eye and the theatre space makes one, seem like the reflection of the other. The theatre in the engraving is quite similar to *Théâtre de Besançon*.

Ledoux’s theatre not only reflects the anatomical shape of the eye, but also emphasizes its function. Every aspect of the theatre, the auditorium, was elaborately designed by Ledoux to provide an environment where “one sees well everywhere” and where “one is well seen.”⁴¹⁹ This means that the space of *Théâtre de Besançon* formally and functionally represents the power and sovereignty of the eye and reveals the impact of the advancements in ocular science on theatre architecture.

⁴¹⁷ Kepler and (trans.), *Optics: Paralipomena to Witelo & Optical Part of Astronomy*. quoted in Camp, “Ocular Anatomy, Chiasm, and Theatre Architecture as a Material Phenomenology in Early Modern Europe.”137

⁴¹⁸ Dijck, “Digital Cadavers and Virtual Dissection.” 139

⁴¹⁹ Vidler , A., *Claude-Nicolas Ledoux: Architecture and Social Reform at the End of the Ancien R.gime*. Cambridge, Mass., 1990, 176 quoted in Dijck. 141

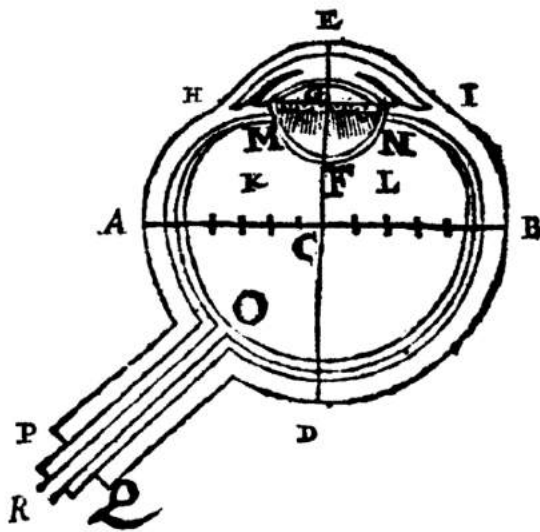

Figure 104. Scheiner's illustration of the eyeball.

Source: Nicholas J. Wade, "Image, Eye, and Retina (Invited Review)," *Journal of the Optical Society of America A* 24, no. 5 (2007): 1229–49, 1230

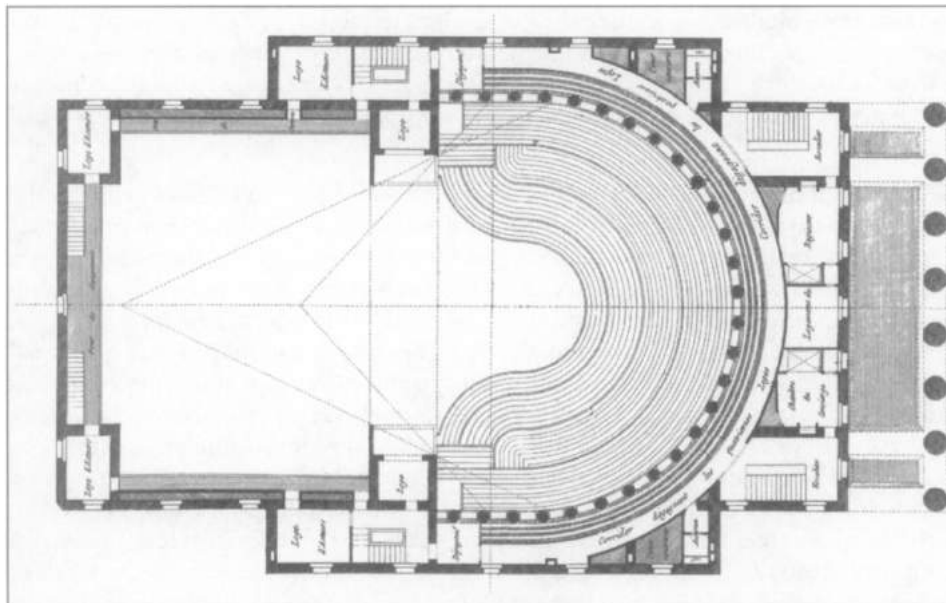

Figure 105. Plan of the fourth loges of Ledoux's design for a theatre at Marseille with sightlines.

Published in Daniel Ramee's *Ledoux*, 1847.

Source: Pannill Camp, "Theatre Optics: Enlightenment Theatre Architecture in France and the Architectonics of Husserl's Phenomenology," *Theatre Journal* 59, no. 4 (2007): 615–33. 623

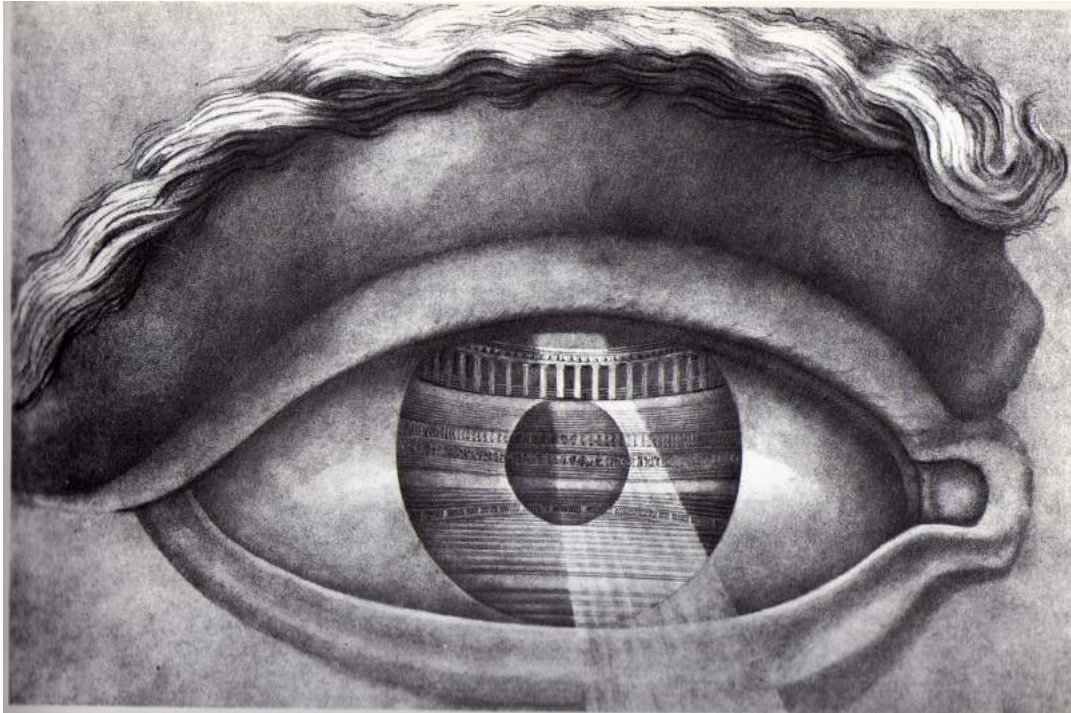

Figure 106. *Coup d'oeil du théâtre de Besançon* from Claude- Nicolas Ledoux's *L'Architecture considérée sous le rapport de l'art, des moeurs et de la législation* (1804)

Source: Pannill Camp, "Ocular Anatomy, Chiasm, and Theatre Architecture as a Material Phenomenology in Early Modern Europe," in *Anatomy Live: Performance and the Operating Theatre*, ed. Maaike Bleeker (Amsterdam: Amsterdam University Press, 2008), 129–46, 139

3.3. Public Dissection: Making the Body Visible

3.3.1. Anatomical Theatre as a Didactic Space

“Here, where in order to hem in human pride,
 There stands a trophy of fleshless skeletons . . .
 . . .
 So why then do you raise your impudent head,
 Wretched humanity, while our life depends
 Upon the corpses of others?”⁴²⁰

⁴²⁰ A Baroque style sonnet that circulated in Bologna in manuscript form quoted in Ferrari, “Public Anatomy Lessons and the Carnival: The Anatomy Theatre of Bologna.”

The fundamental activity housed by the anatomical theatres was the dissection of the cadavers, which enunciated the dead body as a source of knowledge. Surely, the knowledge of the body could not be acquired through mere observation, the action of cutting was required. Without “dissective thinking”⁴²¹ the dead body would mean nothing. What made the corpse a knowledge resource, is the idea and the possibility of cutting it. Foucault expressed the power of dissecting cadavers for acquiring anatomical knowledge as follows:

“Open up a few corpses: you will dissipate at once the darkness that observation alone could not dissipate.”⁴²²

The corpse was a learning tool aiding medical students, researchers and practitioners to understand the living body. Paradoxically, the “dead” enabled the perception of the “living.” In *The Birth of the Clinic*, Foucault elaborated the didactic relationship between the dead body and the living body. According to him, “the need to know the dead must already have existed when the concern to understand the living appeared.”⁴²³ He underlined the fact that the urge to dissect a dead body came from the necessity to fully comprehend the structure and functioning of the living body in order to enhance the quality and duration of living. Relating this concept to the medical gaze he also claims that “medicine was haunted by that absolute eye that cadaverizes life and rediscovers in the corpse the frail, broken nervure of life.”⁴²⁴

Within this context, dissection began to play an important role in medical education, since the training of future physicians relied on the comprehensive understanding of the depths of the human body. Consequently, anatomical theatres where anatomical dissections took place became an essential component of medical schools.

In anatomical theatres, the medical students learned to distinguish between healthy and diseased tissues in living bodies, and gained a better insight into the three-

⁴²¹ Elkins, “Cut Flesh.” 128

⁴²² Bichat, *Anatomie générale, avant-propos*, p. xcix. quoted in Foucault, *The Birth of the Clinic: An Archaeology of Medical Perception*.146

⁴²³ Foucault.126

⁴²⁴ Foucault.166

dimensional shape, texture, and color of the organs, veins and bones. If medical training was confined to anatomical illustrations and texts that reduce anatomical structures to two dimensional flat surfaces, the education would be quite inadequate, causing great failures in medical science.

In anatomical theatres, tactile contact with the cadaver was the exclusive privilege of the anatomy professor. During public dissections the students were not allowed to cut, even touch the body, they were only expected to observe the dissection carried out by the anatomist.⁴²⁵ Depending on the growing consciousness on the importance of practical experience gained by means of the actual dissection of the human body, dissecting rooms began to be built in addition to the anatomical theatres.

In the early 16th century, anatomical dissection transformed into a public lesson from being a private educational practice. People who are not affiliated to the faculty of medicine, as an instructor or student, could attend those public dissection sessions and learn about the human body. This meant that, from then on, anatomical theatre was a school not only for medical students but also for the lay people.⁴²⁶ Explaining the role of the anatomical theatres for the education of the public, José van Dijck wrote:

“Anatomical theatres played a major role in the dissemination of science to a large lay audience. The popularity of anatomical theatres in the Renaissance should be regarded in the context of the rise of Kunst - and Wunderkammer and botanical gardens, which also exposed large crowds to the marvels of nature and science.”⁴²⁷

⁴²⁵ Dijck, “Digital Cadavers and Virtual Dissection.”³²

⁴²⁶ Dijck.³²

⁴²⁷ Dijck.⁴⁰

3.3.2. Anatomical Theatre as a Performance Space

In 1537, Andreas Vesalius (1514-1564) graduated from the medical school of the University of Padua and immediately after his graduation, the university offered him the chair of surgery and anatomy. He also guest-lectured at the University of Bologna and University of Pisa. He was the pioneer of a new way of teaching anatomy that was no longer based on *ex-cathedra* lectures given in traditional classrooms. His education method was based on more practical principles, especially promoting live cadaveric dissection sessions conducted by senior anatomists to acquire direct anatomical knowledge. For this reason, he is referred to as the founder of modern human anatomy.⁴²⁸

In the early sixteenth century, the public dissections performed by Vesalius gave rise to an empirical turn in anatomy, transforming the private education -that is confined to the students of the medical faculty- to a public lesson.⁴²⁹ In addition to Bologna and Padua, in numerous Italian and European cities public anatomy lectures took place. The number of spectators had increased in time and their reasons for attending had become more sophisticated. The audience was no more just a small group of medical students.⁴³⁰ Public anatomy lessons where cadaveric dissections performed attracted people from different social groups including “elites, church officials, professors, students, wealthy travelers and common citizens.”⁴³¹

Until the second half of the sixteenth century no specific attention was paid to the place where these lessons were held, therefore there were not fixed venues designed for these events.⁴³² The chambers or buildings allocated for these public occasions began to emerge in the last decade of 16th century. As explained in detail in Chapter 3.2.3, to accommodate large crowds, anatomical theatres were built all around

⁴²⁸ Di Matteo et al., “Art In Science: The Stage of the Human Body—The Anatomical Theatre of Bologna.” 1875

⁴²⁹ Ferrari, “Public Anatomy Lessons and the Carnival: The Anatomy Theatre of Bologna.”

⁴³⁰ Ferrari.66

⁴³¹ Hallam, *Anatomy Museum: Death and the Body Displayed*.104

⁴³² Ferrari, “Public Anatomy Lessons and the Carnival: The Anatomy Theatre of Bologna.”55

Europe, especially in towns and cities with universities with medical faculties such as Padua, Bologna, Leiden and Edinburgh.⁴³³

It draws attention that, during the sixteenth and seventeenth centuries public anatomy lectures became ritualized ceremonies. Dissections were often accompanied by banquets, processions, concerts and theatrical performances. These ceremonies suggested that “dissection was understood as an entertainment of performance” which underlined the fact that public dissections went beyond their medical and scholarly context.⁴³⁴

In fact, the public anatomy lectures were quite similar to theatrical performances in many aspects. The lessons were divided into phases, the entrance required a paid ticket and there was music to entertain the audience just like in a regular theatre play.⁴³⁵ Within this context, it is possible to say that the anatomical theatres were not theatres only in a formal sense, but also the performance that took place within manifested theatrical qualities. In better terms, the public dissection which was “highly theatrical in character and occurred in a theatrical space.”⁴³⁶

This trend toward the spectacular and ritualistic had its heyday in mid to late sixteenth century especially in the cities of Padua and Bologna. The public dissections performed by Vesalius, Servetus, Fabricius and others in temporary or permanent anatomical theatres attracted hundreds of spectators. Especially in 1530s and 1540s Vesalius initiated the tradition that the senior anatomist seemed like a performer on the theatre stage. The approach of Vesalius favored personal authority over textual authority and attributed a major role to the professor conducting the

⁴³³ Dijk, “Digital Cadavers and Virtual Dissection.” 39

⁴³⁴ Luke Wilson, “William Harvey’s Prelections: The Performance of the Body in the Renaissance Theater of Anatomy,” *Representations*, no. 17 (2018): 62–95.69

⁴³⁵ Giovanna Ferrari, Public Anatomy Lessons and the Carnival: The Anatomy Theatre of Bologna, *Past & Present*, no. 117 (Nov., 1987), pp. 50-106 Retrieved from <http://www.jstor.org/stable/650788>, 82

⁴³⁶ Maaike Bleeker, ed., *Anatomy Live: Performance and the Operating Theatre* (Amsterdam: Amsterdam University Press, 2008).14

public anatomy session as if he was the protagonist of a theatre play.⁴³⁷ As Michael Sappol expressed:

“The anatomist was a performer. Anatomy required showmanship.”⁴³⁸

The frontispiece of the set of seven books, *De Humani Corporis Fabrica* (Fabric of the Human Body) written by Andreas Vesalius in Latin and first published in 1543, presents an impressive depiction of the public anatomy lessons as theatrical events. (Fig.107) The illustration attributed to Jan van Calcar, portrays a vivacious scene of a public dissection conducted by the Vesalius himself and offers the “experience of witnessing a dissection at first hand” to the reader.⁴³⁹ Regarding the avant-garde role of Vesalius in the illustration Hallam wrote:

“Here Vesalius himself performs human dissection, a significant departure from the hierarchical division of roles represented on the title pages of previous anatomical works in which, from the 1490s, the lector read from classical anatomical texts while the demonstrator indicated with a pointer, or his hand, which bodily parts should be dissected and displayed by the sector, usually a surgeon or barber. Instead Vesalius was depicted both lecturing and demonstrating while two barbers (the sectors) were shown at the base of the dissecting table not cutting the body but sharpening blades for the anatomist to wield.”⁴⁴⁰

The frontispiece depicted Vesalius not as a supreme master, just instructing and guiding the dissection process, but as a “protagonist,” actively performing the dissection and also, demonstrating the body pieces. In the image, the gaze of Vesalius was not directed towards the body he was dissecting but to the viewer just like an actor performing on stage. In terms of redefining the status of the anatomist, the illustration introduced a totally new concept to the practice of public dissection. Nevertheless, the focus of interest of the illustration is not the great anatomist Vesalius, instead the body undergoing dissection. This visual composition

⁴³⁷ Wilson, “William Harvey’s Prelectiones: The Performance of the Body in the Renaissance Theater of Anatomy.”69

⁴³⁸ Sappol, *Dream Anatomy*.6

⁴³⁹ “Part V-Animating Bodies, Exhibition Gallery Guide.” 92

⁴⁴⁰ Hallam, *Anatomy Museum: Death and the Body Displayed*. 105

emphasized the actual motive and purpose of public lessons, which is the display of the human anatomy. Surrounding the dissection table, an excited crowd of men gazing at the opened up female cadaver was depicted. By looking at their outfits and gestures, it is possible to say that the audience was a heterogeneous group consisting of people from different social groups, including physicians, professors, clerics, students, and laypeople. The common point of all these men was the intense curiosity towards the interior of the body, especially that of a female.

Although there were no permanent anatomical theatre built in the time when *De Humani Corporis Fabrica* was published, the frontispiece demonstrates an elaborate space which seems to be specially designed for public dissections to take place. The space illustrated in the image has a circular form following the ancient theatre architecture tradition. There are ascending tiers surrounding the stage for the viewers to stand. At the uppermost level of the tiers, there is a circular arcade with Corinthian columns. Above that, there is another storey enabling people to observe the dissection from a higher level and see the dissected cadaver in top view. By selecting this illustration as the frontispiece of his masterpiece, Vesalius reveals his interest in architecture, especially that of the spaces of anatomical scholarship.

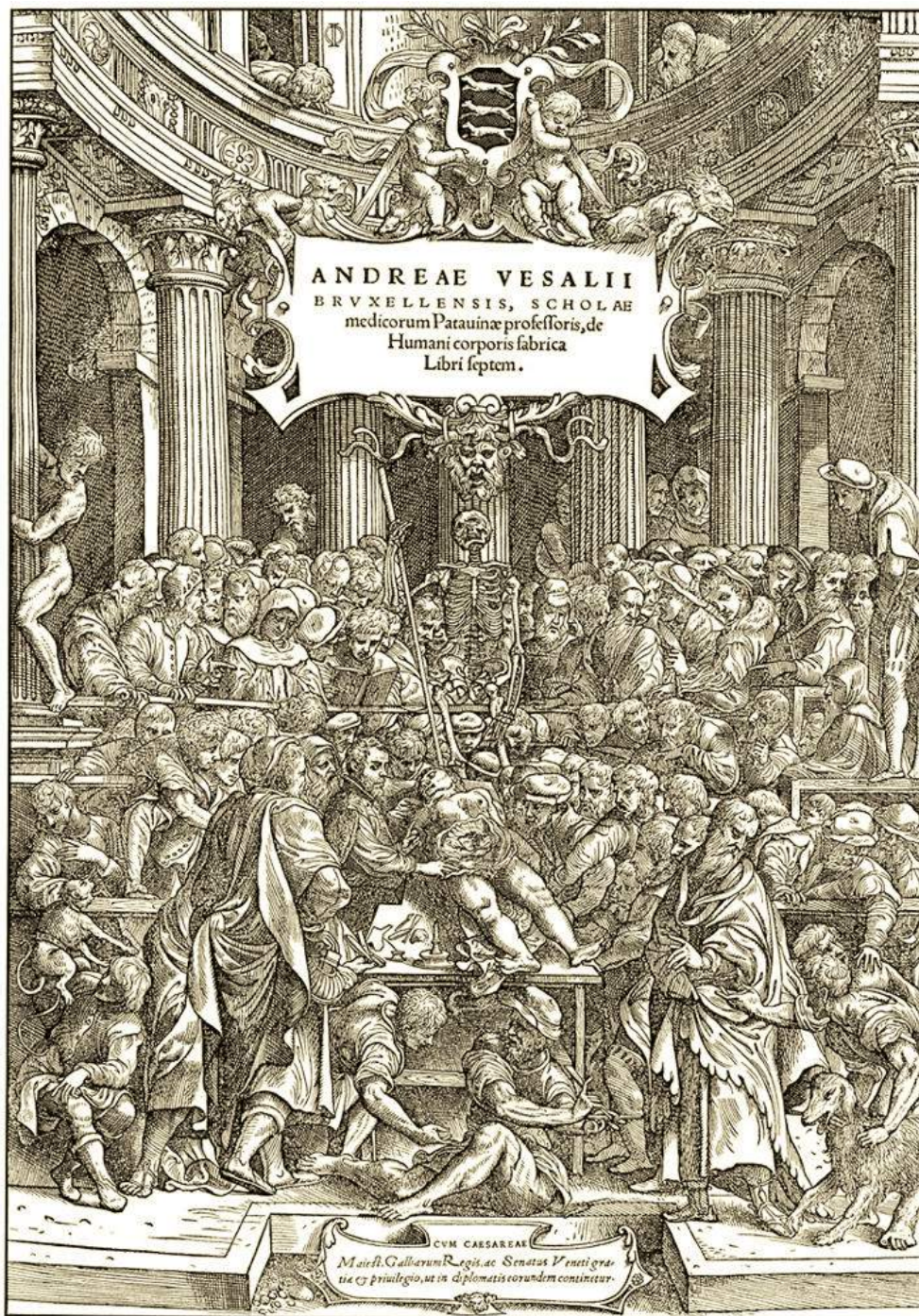

Figure 107. Jan van Calcar, attributed, Frontispiece, woodcut, in Andreas Vesalius, *De humani corporis fabrica libri septem* (Seven Books on the Fabric of the Human Body) (1543, Basel)

Source: Elizabeth Hallam, *Anatomy Museum: Death and the Body Displayed* (London: Reaktion Books, 2016), 105

Another theatrical dimension of the public dissections was the conflict between dead and alive which is visible in the frontispiece of *Fabrica*. In the image Vesalius interacts with the dead body “as performer of it and performer with it” and this dual interaction visually and conceptually constitutes the center of the illustration in a “circuit of performance and identification.”⁴⁴¹ In better terms, the body that Vesalius demonstrates is both his own and that of the cadaver. The curious gaze of the audience, indeed “their epistemological right to see,”⁴⁴² transforms the body of Vesalius to a subject to be viewed, together with the cadaver on display, in a way “cadaverizes”⁴⁴³ the living body of the anatomist. Reciprocally, the cadaver in the illustration is reanimated. William explains this situation as follows:

“Another way to look at the tension through which the body is reconstituted is to divide the performance in the theater of anatomy into a ritual dismantling (dissection) and a reconstitution (anatomy) of the cadaver, acts probative respectively of the body's inanimation and its figurative reanimation. The demonstration that the body is dead-its dissection-preserved by contrast the animation of spectator and anatomist alike.”⁴⁴⁴

Gazing towards the viewer, Vesalius places his right hand upon the dissected body and his left hand points upwards, probably the skeleton above the force. While his hand gestures metaphorically refer to death, his alive body and the bodies of the spectators in motion represent life. In that sense, the illustration perfectly reveals the tension between life and death.

Among the ceremonial public anatomy lectures held in Europe, the ones in Bologna were unique and distinctive for certain aspects. Firstly, the public dissection culture survived for a long time in Bologna as being “intimately related to the structure and historical development of Bologna’s internationally renowned *Studium*.”⁴⁴⁵ Secondly, the majority of the public dissections that took place in Bologna coincided

⁴⁴¹ Wilson, “William Harvey’s Prelectiones: The Performance of the Body in the Renaissance Theater of Anatomy.” 73

⁴⁴² Wilson. 88

⁴⁴³ Wilson. 88

⁴⁴⁴ Wilson. 89

⁴⁴⁵ Ferrari, “Public Anatomy Lessons and the Carnival: The Anatomy Theatre of Bologna.” 52

with the annual carnival. The carnival time was in January which was suitable for the preservation of the cadavers. Like in the other European cities, the public dissections could have been held during the Christmas, when the lessons were suspended, enabling greater number of students and physicians to attend but it was not preferred. This suggests that beyond providing ideal temperatures for the conservation of the corpses, the carnival time was selected because public anatomy ceremony itself was not only considered as a study of anatomy, but also a festive activity.⁴⁴⁶ Also, the arrangement of the public dissections during the carnival season facilitated the attendance of people wearing masks. The opportunity to participate the public dissections in disguise encouraged revelers, especially the ones who were enthusiastic to see the demonstration of female genitalia. In order to curb this inappropriate interest, In 1594 the university scholars decided that under no circumstances the entrance of maskers would be allowed.⁴⁴⁷

The Bolognese public anatomy lessons began to take place in the Palazzo dell'Archiginnasio around 1638, after the incorporation of the anatomical theatre. For over a century and a half, at each carnival these ceremonial lessons were held in the Anatomical Theatre of Bologna. Ferrari describes the public anatomy lecture as follows:

“A medical lector carries out the anatomy of the human body, usually male, which for many days remains on a table in the middle of the theatre, around which the dissectors do their experiments. The professor initiates the discussion among the audience, and then approaches the cadaver to indicate the exhibited parts during his lesson. For fifteen days there is a concourse of medical, philosophical and anatomical lecturers, as well as of scholars. The theatre, especially in the eighteenth century, would be magnificently decorated for the occasion: the walls were hung with damask, candlesticks illuminated the room, and two waxen torches at the head and feet of the cadaver, lit up the dissecting table.”⁴⁴⁸

⁴⁴⁶ Ferrari.96

⁴⁴⁷ Ferrari.99

⁴⁴⁸ Ferrari.50

Ferrari relates the highly theatrical character of the public anatomy lessons and their coincidence with the carnival season in Bologna with the “carnavalesque conception of the world.”⁴⁴⁹ Between 1550 and 1700 entertainment activities and the spaces that accommodated them were quite important. Theatre, dance, literature, and opera were flourishing all around the Europe. It was the time of Shakespeare, Montaigne, Molière, Donne, and Cervantes.⁴⁵⁰ According to Bakhtin, everything was tied “to the world's gay matter, which is born, dies and gives birth, is devoured and devours; this is the world which continually grows and multiplies.”⁴⁵¹ This carnivalesque vision of the world also affected the anatomical teaching and gave rise to the transformation of the public anatomy lecture to a carnivalized event, a festive enjoyment. In this period, as Michael Sappol expressed, “anatomy entered the Baroque.”⁴⁵²

Although fitting to the carnivalesque vision of the era, the gradually increasing theatrical character of the public anatomy lessons and their association with festive activities corroded their scholarly value. On this issue Ferrari wrote:

“The ban imposed on public anatomy lessons outside the carnival period, the obligation to complete the anatomy courses by the end of the carnival, the express permission granted to unknown people in carnival disguise to attend the lessons, the sumptuous decoration of the theatre and its very architectural design: all these measures seem to be aimed at keeping the public anatomy ceremony as magnificent as possible, precisely at the time at which the prestige of the Studium as a whole was in jeopardy.”⁴⁵³

All these factors, aiming to enhance the ceremonial aspect of the public anatomy sessions, strongly damaged the original didactic purpose of them. In addition, Renaissance *episteme* and the cosmological understanding of the time discussed in Chapter 3.1 and 3.2, were reflected on the setting of the public anatomy lectures. The anatomist presented himself as “the depository of the secrets of the microcosm and

⁴⁴⁹ Ferrari.102

⁴⁵⁰ Sappol, *Dream Anatomy*.19

⁴⁵¹ Mikhail Mikhailovich Bakhtin, *Rabelais and His World* (Cambridge: The MIT Press, 1968).195 quoted in Ferrari, “Public Anatomy Lessons and the Carnival: The Anatomy Theatre of Bologna.”103

⁴⁵² Sappol, *Dream Anatomy*.

⁴⁵³ Ferrari, “Public Anatomy Lessons and the Carnival: The Anatomy Theatre of Bologna.”104

the possessor of an intellectual form of knowledge rather than of a practical and therapeutic one” which made the educational aspect of the public anatomy seem almost irrelevant.⁴⁵⁴ Public anatomy lessons which were once seen as the source of anatomical scholarship and indispensable for the education of medical students, had become the gathering point of ignorant revelers who merely looked for entertainment and wanted to witness the revelation of the mysterious secrets of nature.

Within this context, the ceremonial public anatomy lessons that began to take place inside the anatomical theatres towards the end of the 16th century, underlined the fact that the anatomical theatres were not theatres only in an architectural sense but also the activities they accommodated had theatrical character. This proves the status of public dissection as a “mass entertainment” or “public spectacle” and the function of the anatomical theatre as a performance space.⁴⁵⁵

⁴⁵⁴ Ferrari. 58

⁴⁵⁵ Dijck, “Digital Cadavers and Virtual Dissection.” 39

CHAPTER 4

ARCHITECTURE AND THE BODY

Between architecture and the human body there is a deep historical relationship established through analogy. It is no coincidence that the phrase “architectural body” is commonly used while referring to architectural structures.

There are two distinct kinds of interpretation of the analogical relationship between human body and architectural design. One of them focuses on the visual qualities and composition, the other aims establishing functional resemblances and in most cases these two approaches are intertwined.

The first approach, dating back to *De architectura* of Vitruvius, relates the “appearance” of the human body to that of the building, therefore intends to establish proportional and compositional relationships between the parts of the body and the parts of the edifice. As Renaissance *episteme* suggested, the Vitruvian man and other similar studies⁴⁵⁶ in Renaissance mainly employed this approach. Some of the subsequent works such as the Modulor also adopted this kind of an analogy between the human body and the building. On the other hand, there have been cases that epitomize the second approach. In this kind, the analogy “comes from the general aesthetics of functionalism, the equation of the beautiful with the useful or with the expression of usefulness, the idea that an artefact which is well-designed and adapted for its purpose will be seen to be beautiful through a recognition of this fitness for use.”⁴⁵⁷ Like the first one, this approach is also an ancient one, that can be traced back to Aristotle, who argued that “our perception of the beauty of animals arises

⁴⁵⁶ These studies are elaborated in Chapter 4.1.

⁴⁵⁷ Philip Steadman, *The Evolution of Designs: Biological Analogy in Architecture and the Applied Arts* (New York: Routledge, 2008).9

through a rational appreciation of the structure of their parts and the functions of their organs” and each part is seen as “serving some definite purpose, some particular function; but each of these functions of the parts is subservient to, contributes to, the greater purpose of the whole.”⁴⁵⁸

Knowing the fact that the human body is a natural entity and architecture is an artificial creation, the impact, impression and reflection of the body on architecture is easier and more immediate to acknowledge than the influence of architecture on the body. Nevertheless, the existence of numerous impressive representations, practices and theoretical works epitomizing the effect of architectural thinking on the study of the human body underlines the reciprocity of the relationship between the body and architecture. As human body is employed as a reference and source of inspiration in architectural design, body is also studied, visualized and communicated in architectural terms.

4.1 Order, Proportion and Harmony

Since ancient Greece, natural organisms, especially the human body, have been seen as the perfect models of harmonious balance and proportion for the design of architectural, artistic and technological creations. The idea of wholeness and integrity in a structure, assuring the consistent allocation of all the components constituting the whole, rejecting the removal of even a minute part, as it would cause the entire system to breakdown, has been regarded to be the equivalent of the classical ideal of beauty.

The Porch of Maidens, the porch on the south side of Erechtheum (421- 405B.C) supported by six columns in the form of female figure, called as caryatids, is an early example epitomizing the relationship between architecture and body. The porch carried by caryatids is a clear manifestation of the human body imagined as an

⁴⁵⁸ Steadman.9

architectonic element. This remarks that Greeks discovered a correlation between the flawless anatomical structure that holds the body up and the columns supporting the building. In fact, there was a long-established tradition that related the columns to human body in Greek culture. As John Onians wrote, “[t]he Greeks in a sense actually desired their sons and daughters to be like columns. They were even capable of seeing them as columns when they looked at them.”⁴⁵⁹ Doric columns were associated with the male body while ionic columns were related to female body. Within this context, the very existence of caryatids underlines the analogy between



Figure 108. Porch of the Maidens, Erechtheum

Source: John Onians, “Greek Temple and Greek Brain,” in *Body and Building: Essays on the Changing Relation of Body and Architecture*, ed. George Dodds and Robert Tavernor (Cambridge: The MIT Press, 2002), 44–63.60

⁴⁵⁹ John Onians, “Greek Temple and Greek Brain,” in *Body and Building: Essays on the Changing Relation of Body and Architecture*, ed. George Dodds and Robert Tavernor (Cambridge: The MIT Press, 2002), 44–63.54

The desire to relate the body to architecture and vice versa has always had a special position within the history of European culture. The first theoretical study on the subject was presented in *De architectura* by Vitruvius who compared the human body directly to the *body* of a building and listed a set of principles for this analogy that centered around the concepts of proportion, symmetry, and harmony.⁴⁶⁰ The principles established by Vitruvius went beyond just unfolding the meanings and roles of these concepts in architecture and revealed advanced links among them which inspired many Renaissance artists and architects.

The aspiration of relating buildings and other built structures to the human body in terms of proportion, symmetry and harmony had its heyday during the Renaissance under the influence of the cosmological understanding of the time that established a complex relation between macrocosm and microcosm. Among the concepts that shaped the architectural thinking and design of the Renaissance Europe, proportion was considered to be the most important one and in general, it was derived from analogical relationships. In fact, the association between proportion and analogy has an etymological background. The word analogy comes from Greek word *analogia*, the combination of *ana* meaning “upon, according to” and *logos* meaning “ratio” that referred to “proportion”.⁴⁶¹

The Vitruvian man created by Leonardo Da Vinci around 1490 was an archetype for the definition of bodily proportions and provided a solid reference for the artistic and architectural works of Renaissance.(Fig.109) It was based on the proportional theories of Vitruvius explained in the first chapter of the III. Book of *De architectura*:

“... in the human body the central point is naturally the navel. For if a man be placed flat on his back, with his hands and feet extended, and a pair of compasses centred at his navel, the fingers and toes of his two hands and feet will touch the circumference of a circle described therefrom. And just as the human body yields a circular outline, so too a square figure may be found from it. For if we measure the distance from the soles of the feet to the top of

⁴⁶⁰ Vesely, “The Architectonics of Embodiment.” 29

⁴⁶¹ Vesely. 37

the head, and then apply that measure to the outstretched arms, the breadth will be found to be the same as the height, as in the case of plane surfaces which are perfectly square.”⁴⁶²

“Vitruvius’s description was composed of two bodies: one visible, based on human features, and the other invisible, based on ideal human proportions.”⁴⁶³ For Vitruvius, the human body was the source of all geometry. Leonardo illustrated the ideal proportion of the human body as corresponding to the pure geometries of square and circle following the principles given by Vitruvius. Considering the mindset of the time, the square and the circle could be seen as the symbols of the earth and the cosmos. Also, the male figure in the center might be considered as a reference to the microcosm, located at the center of the universe, the macrocosm. Leonardo’s illustration depicted two different positions of a male figure in a juxtaposed manner. By that, he demonstrated that when a man places his feet on the ground and stretches out his arms, he could be contained within the four lines of a square, and when he stood in a spread-eagle position, he could be inscribed in a circle. What Leonardo aimed was to develop universal rules of human proportions that relied on the laws of harmony and beauty.

⁴⁶² Vitruvius, *Ten Books on Architecture*. 72

⁴⁶³ George Dodds and Robert Tavernor, *Body and Building, Body and Building*, 2002, <https://doi.org/10.7551/mitpress/1637.001.0001.142>

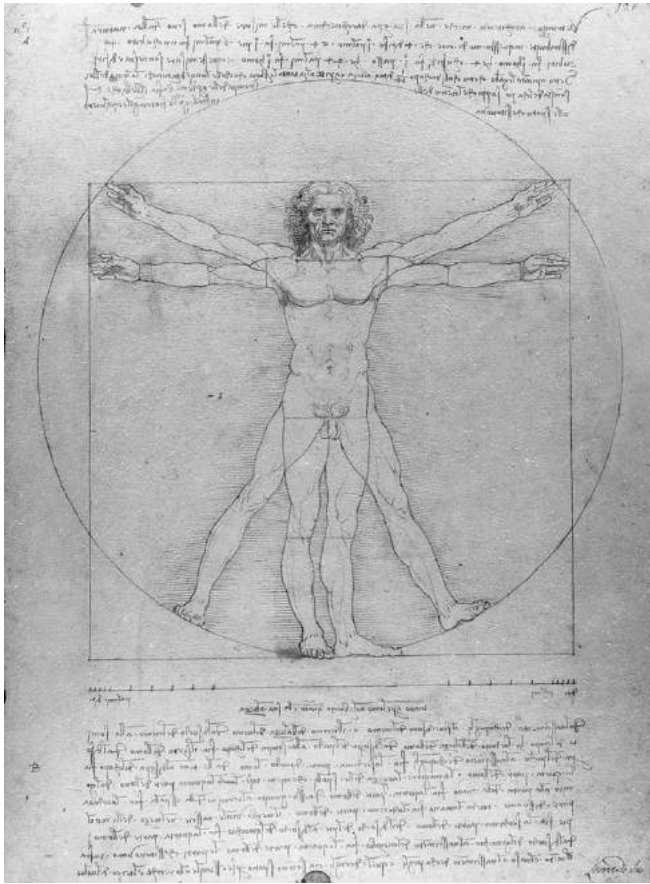

Figure 109. Vitruvian man by Leonardo Da Vinci (c. 1490)

Source: Vitor Murtinho, "Leonardo's Vitruvian Man Drawing: A New Interpretation Looking at Leonardo's Geometric Constructions," *Nexus Network Journal* 17, no. 2 (2015): 507–24, 508

Neo-Pythagorean and neo-Platonic way of thinking highly affected the systems of architectural proportion in the Renaissance. Especially, the parallel drawn between the harmonious correlation among the parts of the human body and the proportional harmony that was aimed in architectural design. The analogies established between the human body and the buildings were "more or less naive."⁴⁶⁴ In general, the bilateral symmetry of the body was to be matched with in an equivalent mirror symmetry of the parts of the building. The proportional ratios found in the measurements of the human figure were intended to be employed to the dimensioning of the building elements. There were more specific approaches such

⁴⁶⁴ Steadman, *The Evolution of Designs: Biological Analogy in Architecture and the Applied Arts*.16

as the ideal palace design of Giorgio Vasari. In his proposal Vasari compared “the facade with the face, the central door with the mouth, the symmetrically placed windows with eyes, the courtyard with the body, staircases with legs and arms.”⁴⁶⁵ In addition to the approach of Vasari, there was another tradition of associating the architectural layout of significant buildings such as temples and churches to the form of the human body. Drawings of Francesco di Giorgio, where “the ghostlike figure of a human body is quite literally mapped onto the plans and elevations of buildings”⁴⁶⁶ clearly demonstrated this understanding. (Fig.110-111)

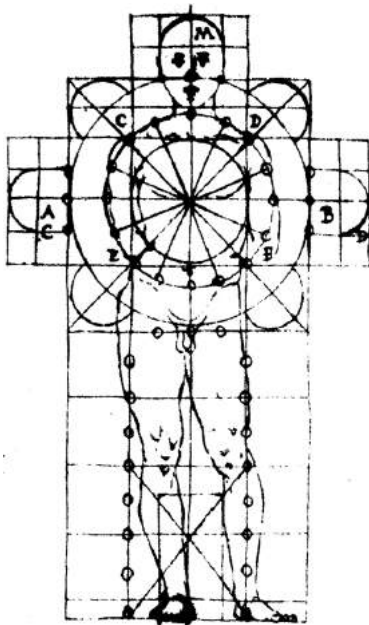

Figure 110. Human figure inscribed in church plan by Francesco di Giorgio

Source: Philip Steadman, *The Evolution of Designs: Biological Analogy in Architecture and the Applied Arts* (New York: Routledge, 2008).17



Figure 111. Entablature on the human form, by Francesco di Giorgio (ca.1492)

Source: Richard J. Betts, “On the Chronology of Francesco Di Giorgio’s Treatises: New Evidence from an Unpublished Manuscript,” *Journal of the Society of Architectural Historians* 36, no. 1 (1977): 3–14, 13

⁴⁶⁵ Giorgio Vasari, *Vasari on Technique*, trans. L. S. Maclehorse, ed. G. Baldwin Brown (London and New York, 1907), pp. 96–7. quoted in Steadman.16

⁴⁶⁶ Dodds and Tavernor, *Body Build*.211

As Wittkower argues, this was not a sign of an anthropocentric world view, instead it was an embodiment of the cosmological view of Renaissance. The human was seen as a representation of the God, therefore the proportions of human body reflected the divine and the cosmic order.⁴⁶⁷

Almost every prominent Renaissance artist-architect was interested in systematizing the proportions of the human body in terms of developing divine geometrical schemes and relating these proportions to architectural and artistic productions. Leon Battista Alberti, Scamozzi, Albrecht Dürer and many others produced significant works on this subject.

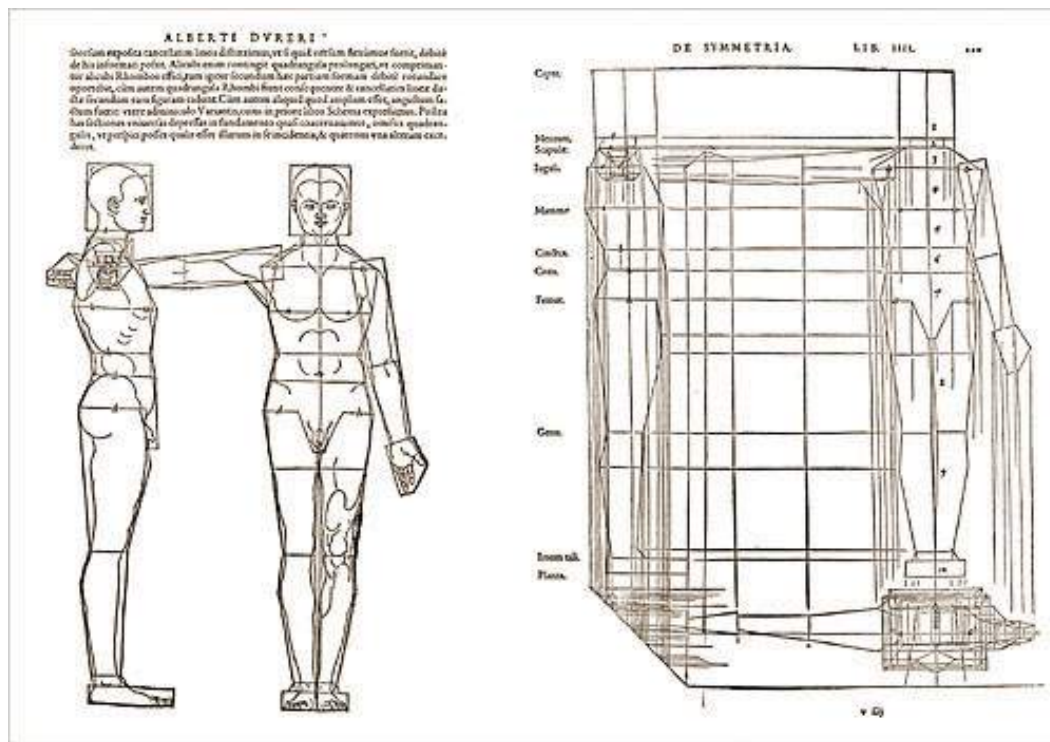

Figure 112. Study on human proportions from *Four Books on Human Proportion* (1532–34) by Albrecht Dürer

Source: “Albrecht Dürer’s Human Proportions,” accessed July 9, 2020, <https://library.uthscsa.edu/2012/03/albrecht-durers-human-proportions/?word=death>.

⁴⁶⁷ Rudolf Wittkower, *Architectural Principles in the Age of Humanism* (London: Wiley, 1962). quoted in Steadman, *The Evolution of Designs: Biological Analogy in Architecture and the Applied Arts*.

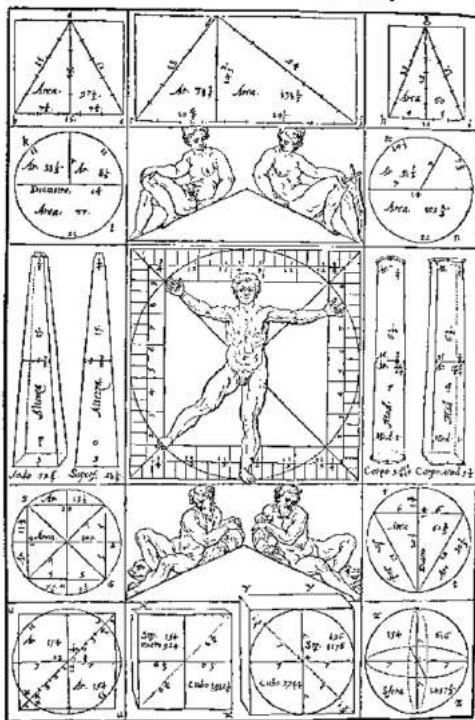

Figure 113. Architectural Forms from Vincenzo Scamozzi, *L'idea dell'architettura universal* (1615)

Source: Alina Payne, "Reclining Bodies: Figural Ornament in Renaissance Architecture," in *Body and Building: Essays on the Changing Relation of Body and Architecture*, ed. George Dodds and Robert Tavernor (Cambridge: The MIT Press, 2002), 94–113. 109

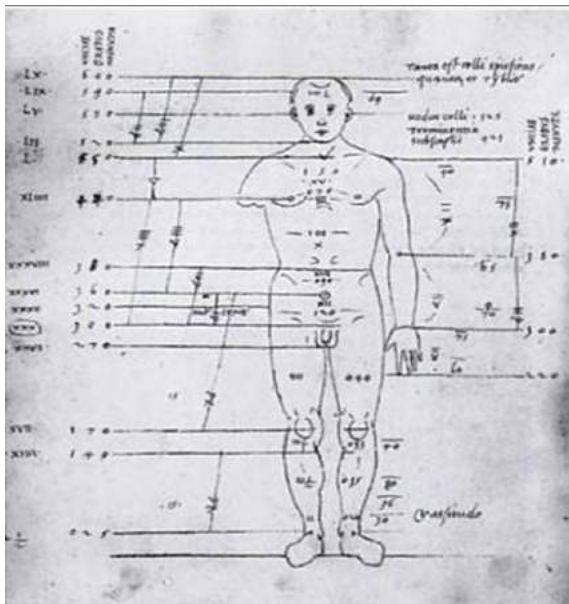

Figure 114. Study on human proportions, Leon Battista Alberti, c.1600

Source: Maria da Piedade Aldinhas de Freitas Ferreira, "Embodied Emotions: Observations and Experiments in Architecture and Corporeality" (PhD Thesis, University of Lisbon, 2015).94

The concept of *vita beata*, originated from the dialogue written by Seneca around 58 AD. named *De Vita Beata* (On the Happy Life), was introduced to the architectural discourse by Leon Battista Alberti. Then, it was blended into the Venetian architecture design tradition. Basically, it was about the search for *vita beata* in terms of bringing the body into the domain of architectural design. It was the “interaction between corporeal images and building images as a means for allegorically apprehending space and form.”⁴⁶⁸ Within this context, Filarete argued that “by playing an analogical game of body images, architects should mold and construct the bodies of both humans and buildings.”⁴⁶⁹ Even centuries later, Valeriano Pastor’s use of body images in architectural imaging, evolved through his training and collaboration with Carlo Scarpa, bears the traces of the Renaissance concept of *vita beata*. Pastor’s sketches and drawings clearly demonstrate that his architectural thinking based on corporeal images:

“For Pastor, architectural drawings are not limited to envisioning the future construction of a building; they are also a figurative means of thinking about the body’s interacting with other bodies. In this procedure of architectural imaging, the substance of a design follows from corporal experiences constructed and construed within a corpus of body images. These thoughtful embodiments bring forth the virtuous nature of architecture—an indispensable condition for implementing a *vita beata*—by dealing with the visceral character of building to foster high spirits.”⁴⁷⁰

⁴⁶⁸ Marco Frascari, “A Tradition of Architectural Figures: A Search for Vita Beata,” in *Body and Building: Essays on the Changing Relation of Body and Architecture*, ed. George Dodds and Robert Tavernor (Cambridge: The MIT Press, 2002), 258–67.260

⁴⁶⁹ Frascari.261

⁴⁷⁰ Frascari.262

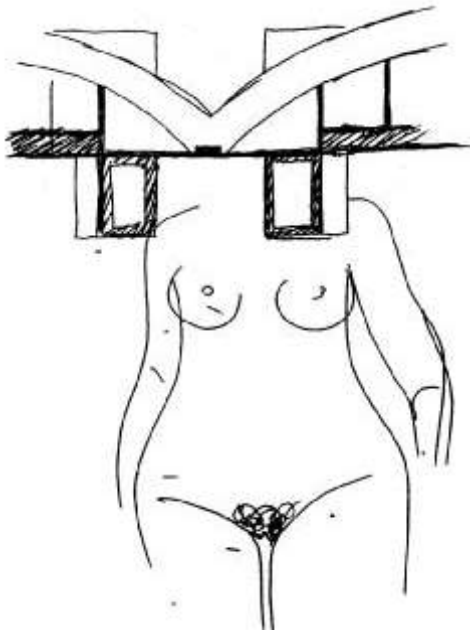

Figure 115. Valeriano Pastor, sketch for the District School Center near Dolo. Nude female torso in a detail study sketch of the ribbed vaulting in the school's laboratories. (From Anfione Zeto, 1, 1989)

Source: Marco Frascari, "A Tradition of Architectural Figures: A Search for Vita Beata," in *Body and Building: Essays on the Changing Relation of Body and Architecture*, ed. George Dodds and Robert Tavernor (Cambridge: The MIT Press, 2002), 258–67.262

The *Modulor* developed by Le Corbusier is the modern expression of the deep rooted tradition of relating the proportions of the buildings to that of the human body. *Modulor* proposed an alternative measurement system aiming to facilitate the construction process. Le Corbusier's major ambition was to establish a universal language in architecture. In that sense, while creating the *Modulor*, he sought for a standard scale based on the proportions of the human body that would be universally valid, eliminating the discrepancy caused by the existence of two incompatible measurement systems, the imperial and the metric. In principle, Le Corbusier's system was based on the height and proportions of a male figure with one arm upraised, related to the Fibonacci sequence and the Golden ratio. He described his system as "a harmonious measure to the human scale universally applicable to

architecture and mechanics.”⁴⁷¹ Following the Pythagorean tradition, Le Corbusier considered mathematics as “the majestic substructure conceived by Man to grant him comprehension of the universe.”⁴⁷² Although Corbusier’s approach seemed quite similar to the studies of Renaissance artists and architects, he clearly expressed his distinct position by saying that:

“I have only stayed within the realm of concrete things, [...] the field of human psycho-physiology; I have concerned myself only with objects falling under the jurisdiction of the eye, avoiding the sorcery of the Renaissance.”⁴⁷³

In fact, Le Corbusier’s approach was beyond establishing a visual proportional relation between the body and architecture, he wanted to redefine architecture in relation to the human scale and relate human to their environment. For him “only the architect can strike the balance between man and his environment: man [as] psycho-physiology and his environment [as] nature and cosmos.”⁴⁷⁴ He also translated his theoretical work to practice by designing many of his projects including *Unité d’Habitation* in Marseille and Church of Sainte Marie de La Tourette based on this anthropometric scale of proportions. Although being considered as a daring, original and influential study, the *Modulor* has been criticized by many architects, scholars and philosophers.⁴⁷⁵

⁴⁷¹ Le Corbusier, *The Modulor* (Cambridge: Harvard University Press, 1966). quoted in William H. Warren, “Constructing an Econiche,” in *Global Perspectives on the Ecology of Human-Machine Systems*, ed. John M. Flach et al. (Boca Raton: CRC Press, 2018), 210–37.

⁴⁷² Le Corbusier, *The Modulor* (Basel: Birkhäuser, 2000), 71 quoted in M. Piedade Ferreira, Duarte Cabral de Mello, and José Pinto Duarte, “The Grammar of Movement: A Step Towards a Corporeal Architecture,” *Nexus Network Journal* 13, no. 1 (2011): 131–49. 137

⁴⁷³ Le Corbusier, *The Modulor* (Basel: Birkhäuser, 2000), 184 quoted in Ferreira, de Mello, and Duarte. 138

⁴⁷⁴ Le Corbusier, *The Modulor* (Basel: Birkhäuser, 2000), 111 quoted in Ferreira, de Mello, and Duarte. 138

⁴⁷⁵ See Natasha Rozhkovskaya, “Mathematical Commentary on Le Corbusier’s Modulor,” *Nexus Network Journal* 22, no. 2 (2020): 411–28. and Ferreira, “Embodied Emotions: Observations and Experiments in Architecture and Corporeality.”

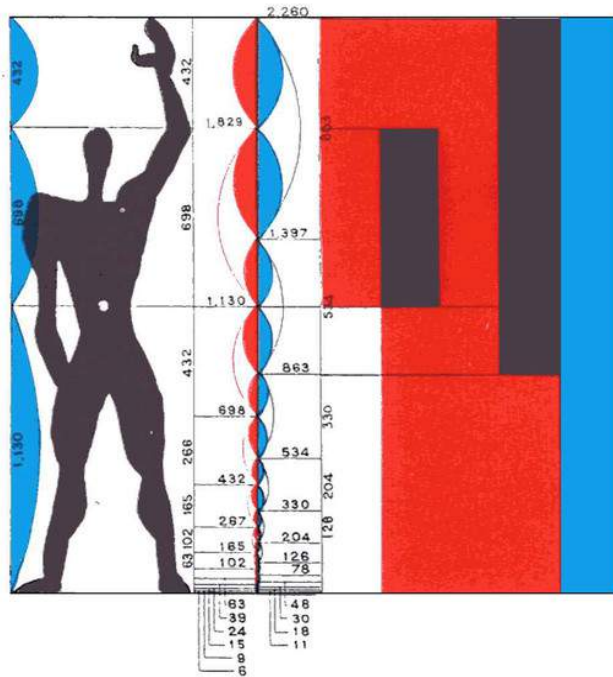

Figure 116. The Modulor by Le Corbusier

Source: Maria da Piedade Aldinhas de Freitas Ferreira, “Embodied Emotions: Observations and Experiments in Architecture and Corporeality” (PhD Thesis, University of Lisbon, 2015), 221

4.2. Space, Form and Function

“The discovery of space has been defined as one of the ‘key conceptual shifts’ to take place in early-modern Europe, with anatomists’ explorations of the body likened to ‘the study of the organization of space.’ This refers to an awareness of the physical space the body occupies in the world as well as the spatial relationship between interior and exterior.”⁴⁷⁶

Many different kinds of similarities could be drawn between architecture and the human body, yet, the most apparent one is that both the body and architectural artifact are self-enclosed three-dimensional entities, with complex interior organizations. In that sense, it would not be wrong to define both as “spatial” objects or creations. Most of the time, the concept of “space” is used in an architectural

⁴⁷⁶ Rosemary Moore, “Paper Cuts: The Early Modern Fugitive Print,” *Object* 17, no. 1 (2015): 54–76. 60

context since “space” constitutes the essence of architecture. As Louis Kahn asserts, “architecture is the thoughtful making of spaces”⁴⁷⁷. Despite the well-established bond between space and architecture, it is possible to claim that the human body is also related to the idea of space, by looking at numerous cases that manifest the fact that the body has been directly or indirectly imagined, depicted and studied in spatial terms, as if it was an architectural space.

For instance, in medical schools the human body has been described and taught to be imagined as an architectural space for educational purposes. As Hallam wrote:

“To help students understand the spatial nature of anatomy, they were asked to imagine their bedroom at the university’s halls of residence, to imagine themselves on top of the wardrobe and then to describe the position of all the furniture in the room – the window, cupboards, bed and so on. This was the kind of imaginative exercise that they would be doing when learning anatomy, they were told by a teacher, except they would be visualizing a body rather than a room.”⁴⁷⁸

It is essential to mention that in *The Birth of the Clinic*, Foucault refers to the interior of the body as “space”, “corporeal space” or “autonomous organic space with its own dimensions, ways, and articulations” which underlines the spatial quality of the human body.⁴⁷⁹

The idea of space includes two significant elements: form and function. As an architectural space cannot be thought independently from its form and attributed function(s), in a similar fashion, a corporeal space cannot be understood without knowing its morphology and the activities it is in charge of within the complicated system that keeps the body alive. In this context, the form and functioning of the body parts and the architectural spaces show pronounced similarities and the second interpretation of the analogy between architecture and body that is mentioned in the beginning of this chapter refers to these.

⁴⁷⁷ Louis Kahn, “Architecture Is the Thoughtful Making of Spaces,” *Perspecta* 4 (1957): 2–3, <https://www.jstor.org/stable/1566850>.

⁴⁷⁸ Hallam, *Anatomy Museum: Death and the Body Displayed*. 51

⁴⁷⁹ Foucault, *The Birth of the Clinic: An Archaeology of Medical Perception*.

4.2.1. Bodyscape: The Architecture of the Body

When the body is dissected, it is seen that the disclosed interiors have spatial qualities. From cell level to organ level, the human body is like a well-designed architectural space. The terms and phrases used in anatomical research and teaching evidently epitomize this argument. Basic concepts of architecture are familiar to anatomists, and they commonly use these concepts in describing the functional structures of cells, tissues, organs and the entire organism.⁴⁸⁰ Terms that are commonly employed while describing architectural entities, such as layers, tubes, compartments and cavities also constitute the frequently used words of anatomical terminology. In addition, phrases that directly include the word “architecture” such as “cytoarchitecture,” and “cortical architecture” exemplify this condition.⁴⁸¹

At this point, it is important to mention the significant medical book named *Human Body* by Logan Clendening, first published in 1927. The particular wording used in the book for the description of the corporal structure and organization could be interpreted as an architectural perspective towards the body. It is possible to argue that the book presents the human body in an architectural manner. For instance, Clendening explains the “cell theory” which is based on the acknowledgement of cells as the basic structural and functional units of all the organisms, thus the human body, as follows:

“The cell doctrine states that all living tissues are made up of units called cells, just as all brick walls are made up of units called bricks; it is probably the most important generalization of biology. No one can understand the processes of the body in health, and even more certainly no one can understand them in disease, unless he thinks in terms of the activities of individual cells or of groups of cells.”⁴⁸²

⁴⁸⁰ Robert B. Trelease, “Anatomy Meets Architecture: Designing New Laboratories for New Anatomists,” *Anatomical Record - Part B New Anatomist* 289, no. 6 (2006): 241–51, <https://doi.org/10.1002/ar.b.20118>. 241

⁴⁸¹ Trelease. 241

⁴⁸² Logan Clendening, *The Human Body* (New York and London: Alfred A. Knopf, 1928). 48

The analogical use of brick walls while describing the cell theory indicates that Clendening perceived the human body as an architectural structure.

“Cells and extracellular material together comprise all the tissues that make up the organs of multicellular animals.”⁴⁸³

Cells are microscopic units and they create surfaces called tissues and tissues form volumetric structures named as organs. This highly complex organization constitutes the human body. The complex composition of the cells, tissues and organs having distinct morphological and functional properties create the “bodyscape”.

“...cell seemed to swell into a veritable universe, so diverse and complex were the activities of its microcosmic chromosomes and their accessories.”⁴⁸⁴

Although being the basic building blocks of the body that are invisible to the naked eye, cells are immensely advanced self-sustaining structures. There are many different types of cells specialized due to their location in the body and their role in the overall system. Each type has a unique form and function, therefore presents a particular spatial quality. To illustrate, muscle-cells have a special structure that gives them the ability of contraction. This is their function in the body, and they cannot be forced to carry out any other type of work. For instance, they cannot assume the functions of gland-cells, which are endowed with the skill of secreting or producing special material, usually a juice, essential in the sustaining of the bodily activities.⁴⁸⁵ It is important to underline the fact that, despite the high specialization, all cells are equipped with common substructures, enabling them to do certain activities to maintain their own life almost in an autonomous manner. Fundamentally, they all consist of cell membrane that separates the interior environment from the outside, nucleus that controls all the cellular activity, cytoskeleton that supports the cell structure and organelles carrying out various

⁴⁸³ Anthony L. Mescher, *Junquera's Basic Histology Text and Atlas*, 14th ed. (McGraw-Hill Education, 2016).

⁴⁸⁴ Logan Clendening, *The Human Body*. 48

⁴⁸⁵ Logan Clendening. 50

functions such as energy production, protein manufacturing, sorting, packaging and translation.

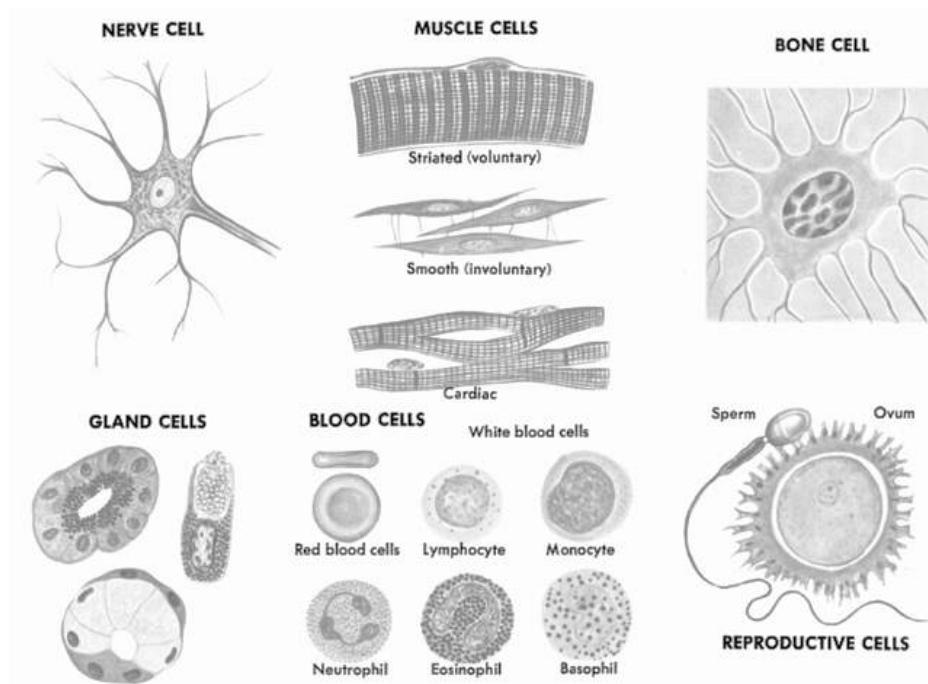

Figure 117. Different types of cells present in the human body. Colors edited by the author.

Source: “An Eye for an Eye? Rather, a Tooth for an Eye,” accessed July 8, 2020, <https://shoker23.wordpress.com/2015/02/26/an-eye-for-an-eye-rather-a-tooth-for-an-eye/>.

Metabolism is an architectural movement that originated in Japan after the World War II, which aimed to develop design models for buildings and cities emulating a living being. Specifically, an analogy between biological growth and architectural megastructures was established. The movement had its first international appearance in CIAM’s 1959 meeting, became very influential during the 1960, and then lost its popularity towards the early 1970s. The word “metabolism” refers to the process of maintaining living cells. Thus, metabolist architects and designers considered buildings and cities as not static but constantly changing entities like a living organism with a metabolism that keeps it alive and actively functioning. Nakagin

Capsule Tower, designed by Kisho Kurokawa and constructed in 1972 only in 30 days, is one of the signature buildings of Metabolic architecture. The building consists of two infrastructure towers and prefabricated capsule units that could be attached when needed and removed when their lifespan is over.⁴⁸⁶ Just like the cells, capsules of Nakagin Tower are both self-sustaining structures equipped with vital facilities and the component units of a larger system. (Fig.118-119-120-121)



Figure 118. The exterior of the Nakagin Capsule Tower as it appeared in 2015, photograph by Noritaka Minami

Source: Ye Ming, “Pictures Reveal Life Inside Tiny Futuristic Cubes,” accessed July 8, 2020, <https://www.nationalgeographic.com/photography/proof/2017/10/nakagin-capsule-tower/>.

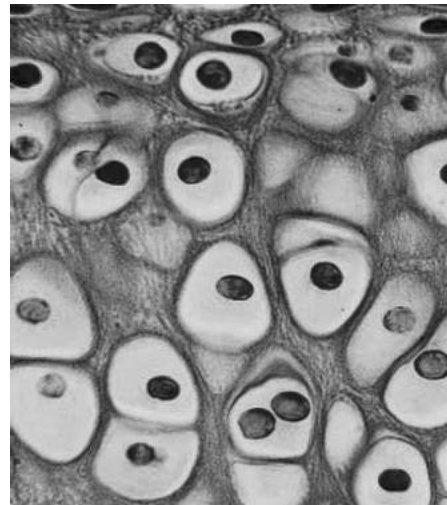

Figure 119. Human cartilage cells under microscope. Colors edited by the author.

Source: Anthony L. Mescher, *Junqueras's Basic Histology Text and Atlas*, 14th ed. (McGraw-Hill Education, 2016).

⁴⁸⁶ Zhongjie Lin, “Nakagin Capsule Tower Revisiting the Future of the Recent Past,” *Journal of Architectural Education* 65, no. 1 (2011): 13–32, <http://www.jstor.com/stable/41319216>.

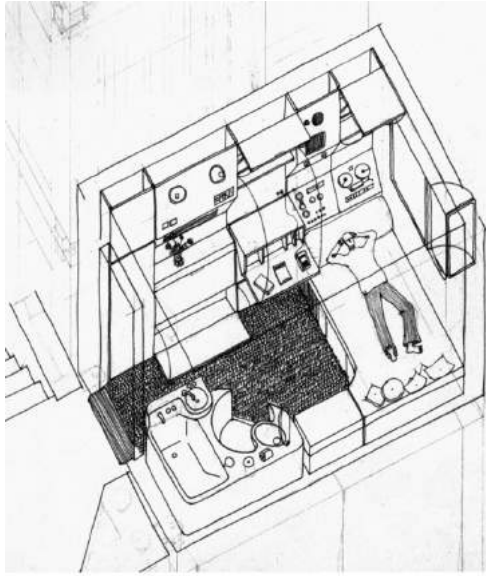

Figure 120. Axonometric of a capsule unit by Kisho Kurokawa Architect & Associates
 Source: Zhongjie Lin, “Nakagin Capsule Tower Revisiting the Future of the Recent Past,” *Journal of Architectural Education* 65, no. 1 (2011): 13–32, 21

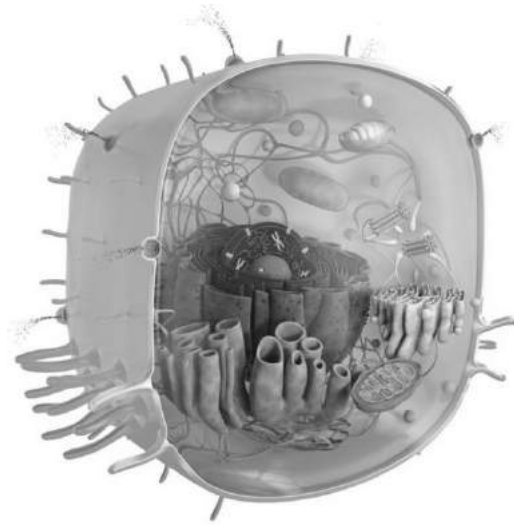

Figure 121. Three-dimensional section model of a cell
 Source: “Living Cell 3D Model,” accessed July 8, 2020, <https://www.cgtrader.com/3d-models/science/medical/living-cell>.

“When a number of cells of the same kind are found together, the structure is called a tissue.”⁴⁸⁷

Although cells are the basic structural and functional units of the human body, for the human eye, the smallest visible body parts are the tissues. For this reason, when the body is read as a spatial composition, tissues come to the fore as surfaces constructing the highly complex topography of the body.

In fact, the idea of focusing on the tissues for the analysis of the body dates back to the studies of French anatomist and pathologist Xavier Bichat (1771-1802), who decoded the corporal space and redefined it in terms of tissues in his influential treatises *Traité des Membranes* (1800) and *Anatomie Générale* (1801). For Bichat there were twenty-one elements constructing the space of the body, categorized due to their morphological character. Foucault wrote on Bichat’s approach as follows:

⁴⁸⁷ Logan Clendening, *The Human Body*. 50

“The major discovery of the *Traité des membranes*, later systematized in the *Anatomie générale*, is a principle of deciphering corporal space that is at once intra-organic, inter-organic, and transorganic. The anatomical element has ceased to define the fundamental form of spatialization and to command, by a relation of proximity, the ways of physiological or pathological communication; it is now no more than a secondary form of a primary space, which, by a process of winding round, superposition, and thickening, constitutes it. This fundamental space is entirely defined by the thinness of the tissue; the *Anatomie générale* enumerates twenty-one.”⁴⁸⁸

With further developments in medicine, the tissual reading of the body introduced by Bichat and his disciples has lost its validity but their approach and perception of the corporal space was highly significant for the development of modern medical knowledge.

According to modern medicine every tissue is “an assemblage of similarly specialized cells united in performing a specific function.”⁴⁸⁹ and there are four types of tissues: epithelial, connective, muscular, and nervous, constructing the entire corporal space. Just having four different types, tissue has the capability to define all the cavities and generate all the organic masses of the body which exist in different colors, forms, textures and states.

⁴⁸⁸ Foucault, *The Birth of the Clinic: An Archaeology of Medical Perception*. 127

⁴⁸⁹ Mescher, *Junqueras's Basic Histology Text and Atlas*. 83

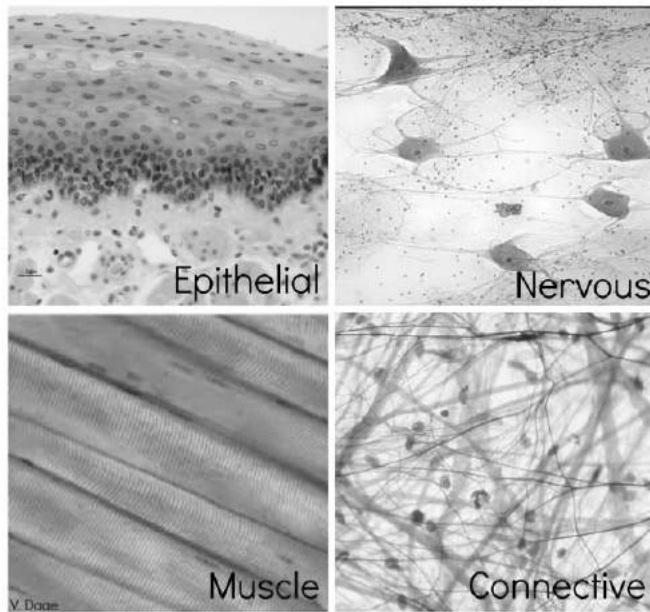

Figure 122. 4 major types of tissues present in human body

Source: Wyatt Sprague, "Tissues," accessed July 8, 2020, <https://www.thinglink.com/scene/786617009851858944>.

LabStudio cofounded by Jenny E. Sabin and Peter Lloyd Jones in 2006 is a hybrid design and research network with active members based at Cornell University, the University of Pennsylvania and Stanford University. Their seminal projects introduce a contemporary perspective to the architectural practice and theory in terms of exploring the intersections of architecture and science and providing new ways of seeing, thinking, modelling and experiencing the formation and operation of biological systems during human development and disease. Especially they investigate the cell and tissue morphogenesis under "normal" and "pathological" conditions.⁴⁹⁰ The project entitled "Branching Morphogenesis" designed by Jenny E. Sabin & Andrew Lucia with Peter Lloyd Jones and Annette Fierro is a public installation originally exhibited in LA at Siggraph 2008. (Fig. 123-124) Sabin and Jones describe the project as follows:

"...this work investigates part-to-whole relationships revealed during networking by lung vascular cells in 4-dimensions. Real-time imaging of

⁴⁹⁰ Jenny E. Sabin and Peter Lloyd Jones, "Sabin + Jones LabStudio : Nonlinear Systems Biology and Design," *AIA Report on University Research 5* (2008).

endothelial cells, which form the lining of all blood vessels, including within the lung, cultured within specialized matrix microenvironments, that either suppress or promote networking, formed the starting point of this project... At the scientific level, the manifestation of such data as a physical, human-scaled architectural construct has the potential to produce new hypotheses regarding the role of tissue architecture, force and environment in controlling morphogenesis.”⁴⁹¹

Another project designed by Sabin+Jones LabStudio named “Ground substance” creates an abstract derivative of human mammary epithelial tissue by quantifying and spatializing cellular and tissue contour information.⁴⁹² (Fig. 125-126)

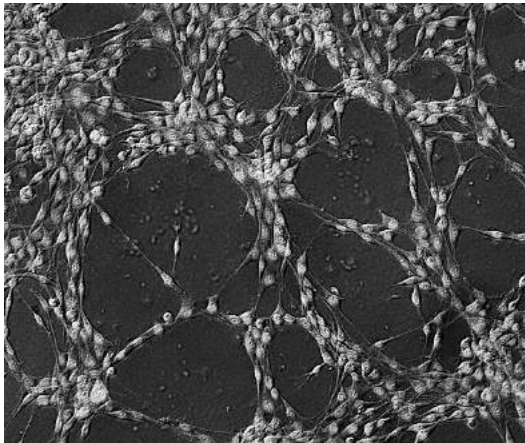

Figure 123. Real-time imaging of endothelial cells. Colors edited by the author.

Source: Jenny E. Sabin and Peter Lloyd Jones, “Sabin + Jones LabStudio : Nonlinear Systems Biology and Design,” 2008.



Figure 124. Branching Morphogenesis installation exhibited in LA at Siggraph 2008

Source: Jenny E. Sabin and Peter Lloyd Jones, “Sabin + Jones LabStudio : Nonlinear Systems Biology and Design,” 2008.

⁴⁹¹ Sabin and Jones.

⁴⁹² Peter Lloyd Jones, “Minding the Gap: Caring for Collaboration between Art & Science by Design,” *Sciart Magazine*, 2018, 1–15.

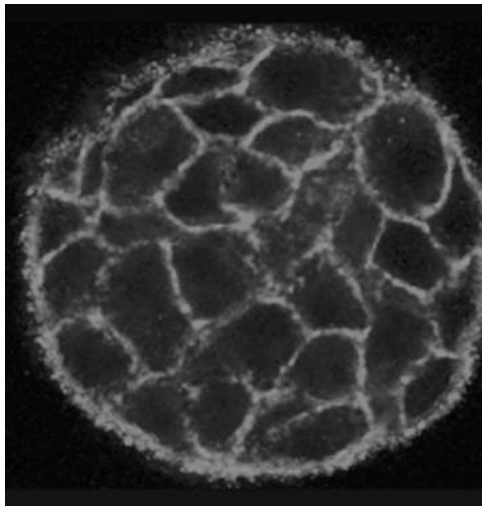

Figure 125. 100um diameter fluorescent image of normal breast tissue culture. Colors edited by the author.

Source: Peter Lloyd Jones, “Minding the Gap: Caring for Collaboration between Art & Science by Design,” *Sciart Magazine*, 2018, 1–15.



Figure 126. Ground Substance project exhibited in Siggraph 2009 in New Orleans

Source: Jenny E. Sabin and Peter Lloyd Jones, “Sabin + Jones LabStudio : Nonlinear Systems Biology and Design,” *AIA Report on University Research 5* (2008).

“In every part of the body these tissues are found together, in such varying numbers as will conduce to the smooth performance of the particular function involved. Nowhere, for any importantly measurable space, do we find any tissue single and alone. When a group of tissues is massed together in one place to perform a function or a set of functions, the term “organ” has been assigned to that structure — the liver is an organ ; so is the eye, the kidney, the foot, the skin, the cerebellum. When a group of organs perform a unified series of functions, we call it a system — the digestive system, the muscular system, the nervous system, etc.”⁴⁹³

As explained by Clendening, the stratification of the tissues creates the organs of the body and the complex arrangement of the organs in the body create a harmonious composition of masses and voids just like an architectural setting.

⁴⁹³ Logan Clendening, *The Human Body*. 51



Figure 127. Dissected heart, brain and lung. Image prepared by the author.

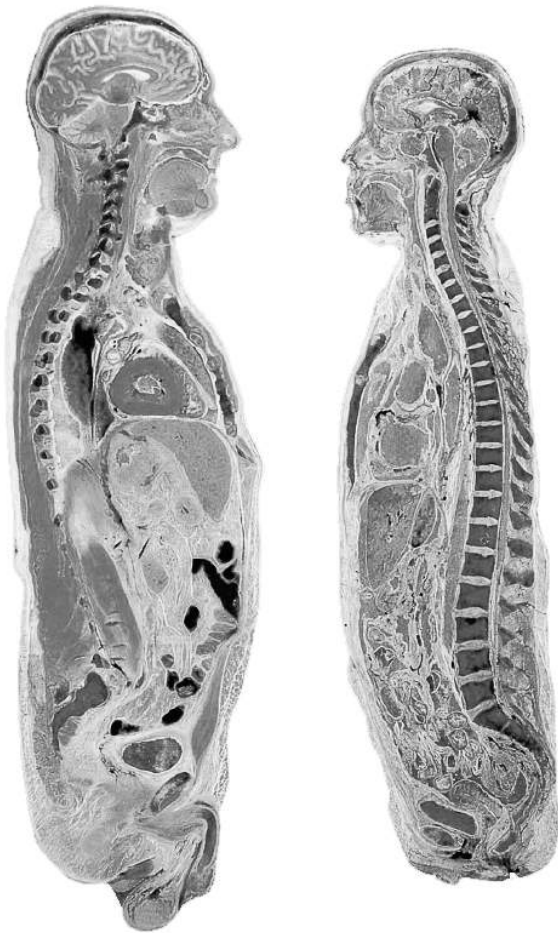

Figure 128. Midsagittal Slices of a Male and Female Body, Body Worlds Exhibition by Gunther von Hagens. Colors edited by the author.

Source: Giovanni Aloï, ed., "The Problematic Exposure of Flesh," in *Antennae*, 2010, 50

As a living organism, the human body is an autonomous and dynamic entity. It can change size and shape by itself. It is mobile, it can translocate and move in different axes. In addition to its movement as a whole, its parts are capable of moving individually. The body's flexible nature enabling it to grow, transform and move inspired the design of flexible and dynamic spaces. The projects of Greg Lynn that conceive the architectural space as an organism embodies this approach. In contrast to the traditional conception of architectural structures as rigid and upright entities, Lynn's designs propose structures that have a "range of motion, mutation and flexibility".⁴⁹⁴ Lynn's moving architecture, executed with software developed for movie animations "demonstrate the broad presence and appeal of flexibility in contemporary design thinking."⁴⁹⁵ The Embryological House (1997–2001) project of Greg Lynn uses human morphology and morphogenesis to create a series of one-of-a-kind houses that are customized for individual clients and adaptable to a full range of sites and climates. (Fig. 129) By that, the houses establish a flexible network of dynamic connections to their environments.⁴⁹⁶ In the project description, Lynn wrote that:

"This marks a shift from a Modernist mechanical kit-of-parts design and construction technique to a more vital, evolving, biological model of embryological design and construction."⁴⁹⁷

⁴⁹⁴ Greg Lynn, 1997. "An Advanced Form of Movement," *After Geometry*, Architectural Design Profile No. 127. London. quoted in Dodds and Tavernor, *Body Build*.

⁴⁹⁵ Dodds and Tavernor.

⁴⁹⁶ Dodds and Tavernor.294

⁴⁹⁷ Greg Lynn, FORM, project description for the Embryological House quoted in Ingeborg M. Rocker. "Versioning: Architecture as series?." (2008).

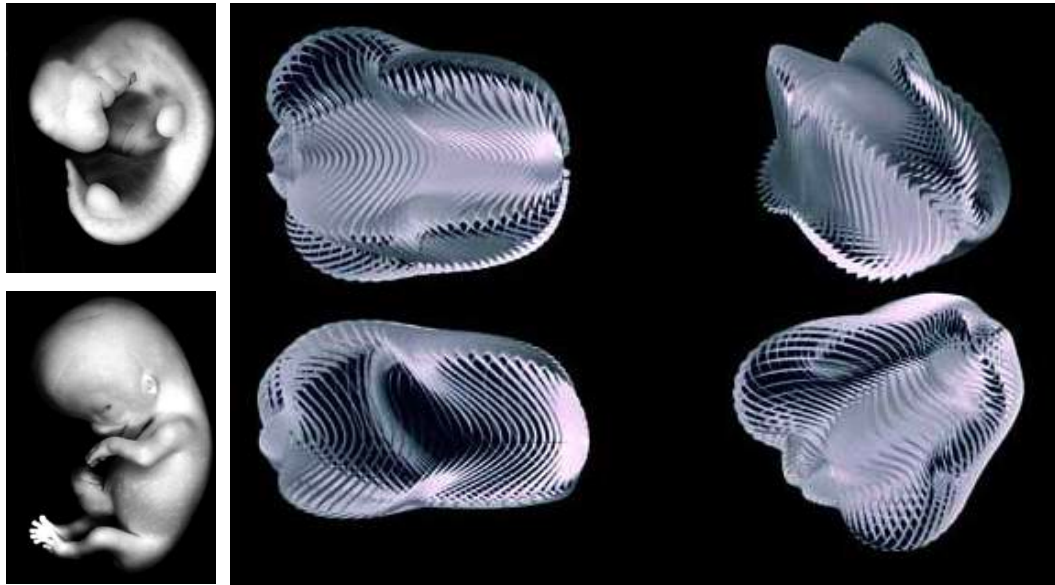

Figure 129. Greg Lynn, Embryological House

Source: Ingeborg M Rucker, “Versioning: Architecture as Series?,” *First International Conference on Critical Digital: What Matter(S)?*, 2008, 157–70, 165

“It is the bony skeleton which gives the body its general shape. The bones are held together by ligaments of connective tissue, allowing movement between the bones; and these points of juncture, which are much more intricate than they appear to be, are called joints. The movements of the joints are made possible by the contraction of muscles. Muscles are attached from one bone to another, the spots of attachment being known technically as the point of origin and the point of insertion.”⁴⁹⁸

Anatomical analogy could be seen as one of the most common and influential models relating the human body to architecture. As defined by Philip Steadman, it is based on a metaphorical comparison between the skeleton system and the supporting structural framework of columns, beams, piers and vaults.⁴⁹⁹ (Fig. 130) The relation between the structural arrangement of buildings and the skeletal form of organisms is found at least as early as 1770s. Through the steel-frame architecture of the Chicago of the 1880s and 1890s, this analogy became especially visible due to the detachment of the façade - the “skin”- from the structural system - the “bones”- of the building.⁵⁰⁰ (Fig. 131) The free-standing type of columnar structure, that became

⁴⁹⁸ Logan Clendening, *The Human Body*. 53

⁴⁹⁹ Steadman, *The Evolution of Designs: Biological Analogy in Architecture and the Applied Arts*.39

⁵⁰⁰ Steadman.39

widespread in 20th century with the rise of Modern movement, was considered as an “internal skeleton.”⁵⁰¹ Dom-ino House (1914-1915) which was a project developed by Le Corbusier exemplifies this idea. It was a mass produced reinforced concrete skeleton which could be prefabricated and used for providing housing to the homeless people after the war.⁵⁰² (Fig. 132)

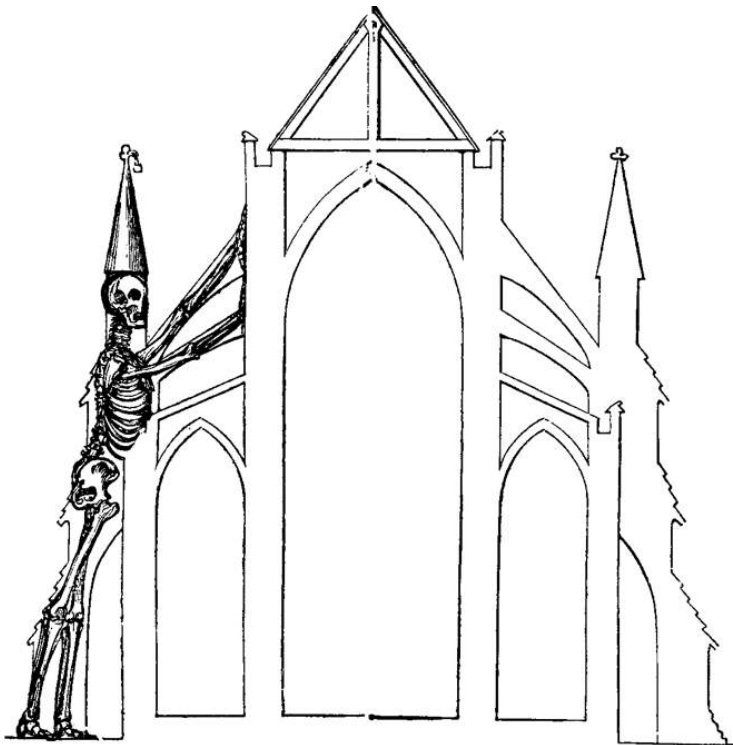

Figure 130. A. Bartholomew, diagram comparing the counter-abutments of Gothic vaulting with the human skeleton

Source: Philip Steadman, *The Evolution of Designs: Biological Analogy in Architecture and the Applied Arts* (New York: Routledge, 2008), 40

⁵⁰¹ Steadman.39

⁵⁰² Benton, Tim. "Dom-ino and the Phantom Pilotis." (2014): 13-37.



Figure 131. Reliance Building in Chicago under construction, August 1st 1894

Source: Joanna Merwood, "The Mechanization of Cladding: The Reliance Building and Narratives of Modern Architecture," *Grey Room*, no. 4 (2001): 52–69, <http://www.jstor.com/stable/1262558>, 57

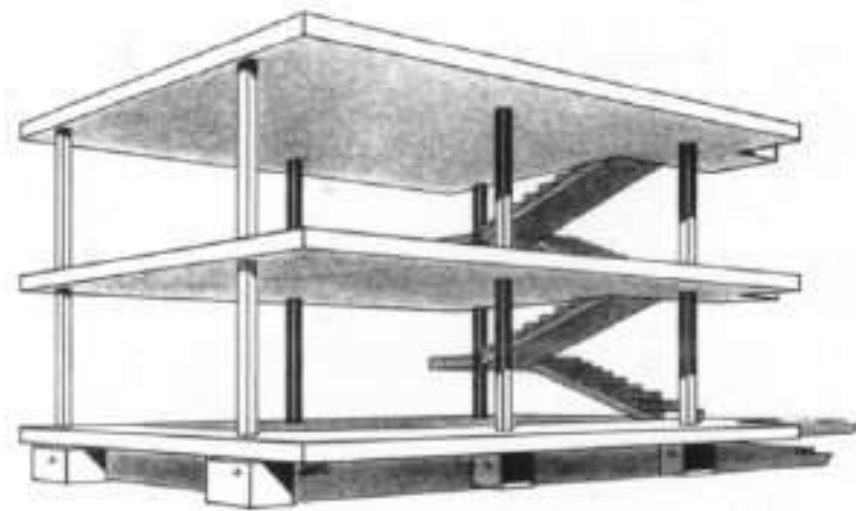

Figure 132. Dom-ino House by Le Corbusier, 1914-1915

Source: Robert Vierlinger, Arne Hofmann, and Klaus Bollinger, "Emergent Hybrid Prefab Structures in Dwellings," *Proceedings of the International Association for Shell and Spatial Structures (IASS) Symposium*, 2013, 1–7, 1

“There used to be an old catch question which quiz-masters in anatomy asked: “What is the largest organ of the body?” — the answer being: “The skin.” Not only that, but it is one of the most interesting and mystic of structures. It is that outer rampart which separates us from the rest of the universe, the sack which contains that juice or essence which is me, or which is you, a moat defensive against insects, poisons, germs, and surgeons, through which they must break before they can storm the citadel.”⁵⁰³

The skin is the outermost organ of the body and it gives the body its appearance. It constitutes both the exterior of the body and the border between the exterior and the interior. In a way the skin is “a threshold into an interior space”⁵⁰⁴ and serves as a surface of encounter between outside and inside.

When the composition and the function of the human skin is investigated it is seen that there are many concepts that could be interpreted in an architectural sense. The metaphor of considering the enclosure system of a building as “skin” is commonplace in architectural parlance. The fundamental function of the human skin is to constitute an interface between inside and outside. Similarly, architecture provides an internal environment, where façades separate this internal environment from the exterior. In that sense, the primary analogy between the skin and the building envelop is the “task of creation of a difference: the establishment of an internal environment.”⁵⁰⁵ The border between inside and outside must include the mechanisms for the exchange of matter and energy to sustain metabolism. Although the human skin seems like a homogenous and smooth structure, it comprises multiple layers, passageways and substructures to provide protection and enable the transfer of vital substances such as the air and the water. Just like the human skin, the building façade is a complex structure including different layers, openings and subsidiary components to be able to carry out functions such as sealing, insulation, environmental control, ventilation and lighting. This means that, in addition to the

⁵⁰³ Logan Clendening, *The Human Body*.68

⁵⁰⁴ Moore, “Paper Cuts: The Early Modern Fugitive Print.”60

⁵⁰⁵ P. Gruber and S. Gosztanyi, “Skin in Architecture: Towards Bioinspired Facades,” *WIT Transactions on Ecology and the Environment* 138 (2010): 503–13, <https://doi.org/10.2495/DN100451>. 504

separation of the internal environment from the exterior, both skin and the building envelope are permeable structures, facilitating the substance exchange to ensure the continuity of “metabolic” functions and provide comfort. In this context, the skin of humans and other organisms serve as a model for the development of advanced façade systems. Gruber and Gosztonyi argue that:

“Today’s facade technology still goes into the direction of separation of functions into layers and their incorporation within various building components, which are then ultimately combined in a modular façade... Biomimetics is increasingly used as innovation method for novel solutions in facade technology, with approaches targeted to structure and energy efficiency.”⁵⁰⁶

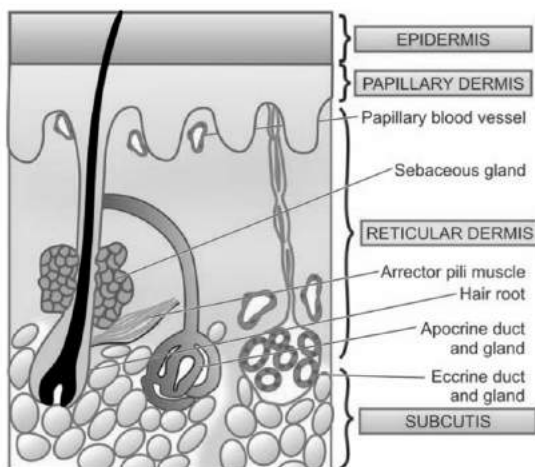

Figure 133. Diagrammatic section of the human skin showing different layers and substructures. Colors edited by the author.

Source: Harsh Mohan, *Textbook of Pathology*, 6th ed. (Jaypee Brothers Medical Publishers, 2010), 768

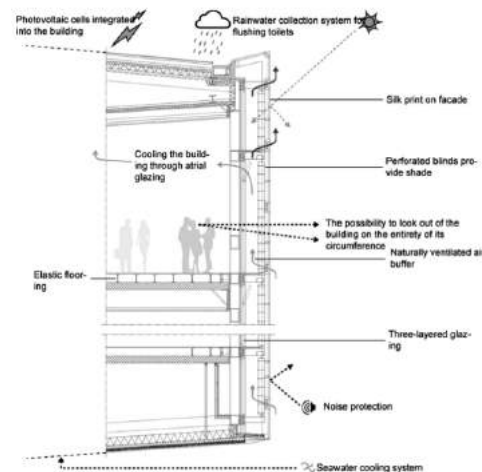

Figure 134. Facade cross-section of the Nykredit bank building, designed by Schmidt Hammer Lassen architects

Source: Janusz Barnaś, “Double-Skin Façades – The Shaping of Modern Elevations – Technology and Materials,” *Technical Transactions, Architecture*, no. 7 (2014): 5–1, 11

eSkin project funded by the National Science Foundation and jointly housed at the University of Pennsylvania and Cornell University, focuses on the design of a responsive building façade based on the cell biological studies in Sabin Design Lab

⁵⁰⁶ Gruber and Gosztonyi.

at Cornell University. It explores “materiality from nano to macroscales based upon an understanding of the dynamics of human cell behaviors.”⁵⁰⁷ (Fig. 135)

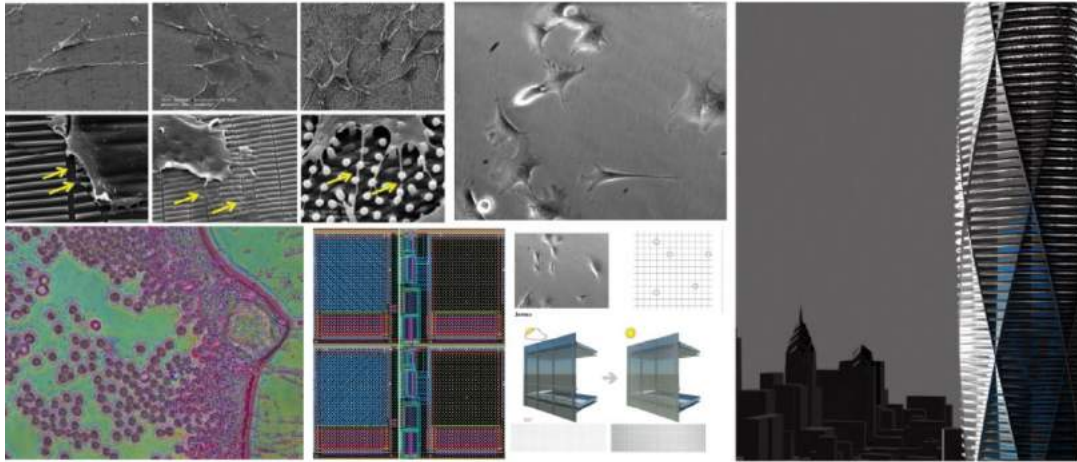

Figure 135. eSkin project

Source: Peter Lloyd Jones, “Minding the Gap: Caring for Collaboration between Art & Science by Design,” *Sciart Magazine*, 2018, 1–15.

Another important characteristic of the skin is its ability to function like a screen broadcasting information about the present condition of the body. “Blushing, blanching, sweating, and goose bumps all convey a certain degree of social communication.”⁵⁰⁸ The physicians can study, diagnose and treat a disease through the skin. By distinguishing the changes in the texture, form, color of the skin and the pattern of lesions, medical practitioners are able to detect the illness and track its progress.⁵⁰⁹ In that sense, it is possible to say that the topology of the skin provides social, psychological and physiological information about the body. Regarding this Clendening wrote:

“A great dermatologist has called it “the mirror of the system.” How its texture and colour change with changes in bodily health — now white with the pallor of fatigue or sepsis, now blue with the cyanosis of heart-failure,

⁵⁰⁷ Jenny Sabin Lab, “eSkin,” accessed July 8, 2020, sabinlab.com/eskin.

⁵⁰⁸ Rene Croteau, “The Analogy of Skin in Architecture Revisited” (Master’s Thesis, Florida International University, 2006).2

⁵⁰⁹ Kristin D. Hussey, “Seen and Unseen: The Representation of Visible and Hidden Disease in the Waxworks of Joseph Towne at the Gordon Museum,” *19: Interdisciplinary Studies in the Long Nineteenth Century*, no. 24 (2017): 1–10, <https://doi.org/10.16995/ntn.787.5>

now greyish-yellow with what physicians call the cachexia of degenerative disease! It reacts to heat, by pouring out perspiration, which cools on evaporation; to bitter cold, to the light of the sun, to the blowing of the winds. The very storms of the soul are recorded upon it — the deep flush of anger or humiliation, the pale tenseness of fear or excitement, the sparkling iridescence of triumph or of ecstasy. The end organs of feeling, attaching it by a million fine nerve-filaments to the brain, are largely responsible for our feeling of personality, of entity.”⁵¹⁰

The highly popular concept of the 21st century architecture, media facades, could be discussed in relation to this advanced feature of the human skin. BIX Light and Media Façade on Kunsthaus Graz, designed by Berlin based studio *realities:united*, completed in 2003, sets an important model for embodying this relation.

“BIX is the 900 m² light and media installation in the façade of the Kunsthaus in Graz. It makes it possible to program the façade like a computer monitor and to broadcast projections, animations, or messages into the urban space.”⁵¹¹

The high-tech façade that is also referred to as “communicative display skin”, broadcasts information just like the human skin and enhances the analogical relationship between the building façade and the skin.

⁵¹⁰ Logan Clendening, *The Human Body*.68

⁵¹¹ Ethel Baraona Pohl, “BIX Light and Media Façade at MoMA,” ArchDaily, accessed July 8, 2020, <https://www.archdaily.com/89408/bix-light-and-media-facade-at-moma>.



Figure 136. BIX Communicative Display Skin for the Kunsthhaus Graz, 2003, view from Schlossberg

Source: Ethel Baraona Pohl, "BIX Light and Media Façade at MoMA," ArchDaily, accessed July 8, 2020, <https://www.archdaily.com/89408/bix-light-and-media-facade-at-moma>.

⁵¹²The "skin and bone" analogy, relating the building envelope to the "skin" and the structural system to the "bones" of the body is another highly referred concept. The emergence of this analogy corresponds to the mid-nineteenth century when the iron and glass exhibition halls, railway stations and conservatory buildings began to flourish. These edifices were the first structures using the possibilities provided by the new technologies of the time allowing the elimination of massive load-bearing walls. In 1860 Gottfried Semper published a significant theoretical work that elaborated on the idea of the separation of structure from the façade of the building.

⁵¹³ As mentioned at the beginning of this subchapter, the design of curtain walls suspended from cantilevered slabs was an approach developed in Chicago School during the last decades of the nineteenth century became an influential expression of this separation. Reliance Building (1890-4) designed by the distinguished members

⁵¹² Christian Schittich, ed., *In Detail: Building Skins* (Basel: Birkhäuser, 2001).

⁵¹³ Schittich, quoted in Croteau, "The Analogy of Skin in Architecture Revisited." 1

of Chicago School, Charles B. Atwood, John Wellborn Root, Daniel Burnham, is considered to be an important example of this approach.⁵¹⁴ (Fig. 131) In the early 20th century, the “skin and bone” metaphor became more visible through the works of Modernist architects. “Five Points of Architecture” are the main principles of Modern architecture established by Le Corbusier and they advocate the detachment of the building envelope from the structural system. The replacement of the load bearing walls by a grid of reinforced concrete columns constituted the basis of the new aesthetic defined by Le Corbusier. The absence of supporting walls enabled the free designing of the ground plan and the façade. As external walls of the building were freed from their structural role, they could be designed in a flexible manner. In this context, “the screen walls whose function is not structural, but simply to divide space and keep out the elements, would be equivalent to membranes and skin.”⁵¹⁵ (Fig. 137) In addition, the buildings of Mies van der Rohe were often referred to as “skin and bones architecture” due to their steel structure and glass enclosure suggesting a new understanding of simplicity and transparency. (Fig. 138) On this subject Rene Croteau wrote:

“By 1922, glass curtain walls enclosed the twenty four towers at the center of Le Corbusier’s visionary drawings for a new city, Ville Contemporaine. In the same year, Ludwig Mies van der Rohe also proposed a glass skyscraper design: the transparent curtain wall in his Friedrichstrasse Station project was a deliberate attempt to preserve the strength and clarity that the steel frame exhibited during construction. These early examples of the clear delineation between structure and enclosure developed into one of the main tenets of modern architecture.”⁵¹⁶

⁵¹⁴ William J.R. Curtis, *Modern Architecture Since 1900* (London: Phaidon Press, 1982). 46. quoted in Croteau, “The Analogy of Skin in Architecture Revisited.” 1

⁵¹⁵ Le Corbusier, *Précisions sur un État Present de l’Architecture et de l’Urbanisme*, Collection de L’Esprit Nouveau (Paris, 1960), 24. quoted in Steadman, *The Evolution of Designs: Biological Analogy in Architecture and the Applied Arts*.39

⁵¹⁶ Croteau, “The Analogy of Skin in Architecture Revisited.”



Jusqu'au béton armé et au fer, pour bâtir une maison de pierre, on creusait de larges rigoles dans la terre et l'on allait chercher le bon sol pour établir la fondation.

Download

On constituait ainsi les caves, locaux médiocres, humides généralement.

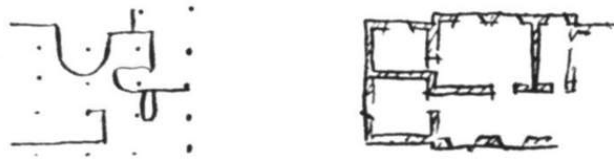

Puis on montait les murs de pierre. On établissait un premier plancher posé sur les murs, puis un second, un troisième; on ouvrait des fenêtres.

Figure 137. Sketches showing the separation of the "skin and bone" from the frontispiece of Le Corbusier, "The Five Points of a New Architecture," 1929

Source: Werner Oechslin and Wilfried Wang, "Les Cinq Points d'une Architecture Nouvelle," *Assemblage*, no. 4 (1987): 82-93, <http://www.jstor.com/stable/3171037>.



Figure 138. Neue Nationalgalerie in Berlin designed by Mies van der Rohe (1968)

Source: Evan Rawn, "Material Masters: Glass Is More with Mies van Der Rohe," ArchDaily, accessed July 8, 2020, <https://www.archdaily.com/574575/material-masters-glass-is-more-with-mies-van-der-rohe>.

As the human body is considered as a spatial entity, disease, which is a significant part of the life cycle, could be seen as the (de)formation and (de)generation of the space of the body. Through disease, the bodyscape goes through metamorphoses and its topography gets redefined, by that, new corporal landscapes are generated. When the body is perceived as a construction, disease becomes the means of deconstruction and reconstruction of the body. Foucault describes the disease as follows:

“it(disease) is a set of forms and deformations, figures, and accidents and of displaced, destroyed, or modified elements bound together in sequence according to a geography that can be followed step by step. It is no longer a pathological species inserting itself into the body wherever possible; it is the body itself that has become ill.”⁵¹⁷

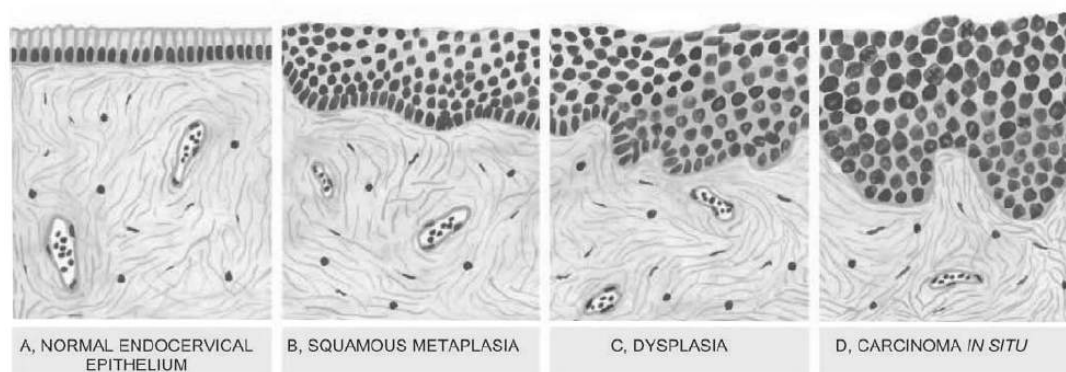

Figure 139. Schematic diagram showing sequential changes in uterine cervix in case of cancer

Source: Harsh Mohan, *Textbook of Pathology*, 6th ed. (Jaypee Brothers Medical Publishers, 2010), 57

Pathogenesis, the progress of disease inside the body, is not an arbitrary process, it has its own patterns and trends of diffusion because while developing inside the body, disease adopts the spatial organization of the body. Disease generates, regenerates and degenerates within the geometric limits set by the space of the body.

Disease operates in accordance with the spatial guidelines proposed by the body and it follows the order of the corporal space. Therefore, the space of the disease is the space of the body. Foucault describes this condition as:

“The space of the body and the space of the disease possess enough latitude to slide away from one another.”⁵¹⁸

⁵¹⁷ Birth of the Clinic

⁵¹⁸ Birth of Clinic pg.10

4.2.2. Architectural Visualization of the Body

The analogical relationship between architecture and the body has also manifested itself in the anatomical and architectural representation and display where the most evident examples are found in the intriguing world of anatomical illustrations. Clare Guest described this condition as follows:

“...parallels between architectural and anatomical illustration were underpinned by the analogy between building and body in the one complete extant ancient work on artistic theory, Vitruvius’ *De architectura*, where corporeal proportion provides the exemplar for architectural proportion. Building-body analogies concerned not only quantitative proportion but ends and harmony of qualities; if the building was a body, its ‘soul’ was the virtuous activity which it was designed to house. Vitruvian terminology echoes through early anatomy, in Cardano’s adoption of the Vitruvian term *ichnographia* (designation of area) for anatomical illustration and in Estienne’s *De dissectione*, where allusions to *venustas*, *convenientia* and *concord* of parts recall Vitruvius’ discussion of *symmetria* and *eurythmia* as correspondence of parts to the whole.”⁵¹⁹

Before examining the deeper and more implicit associations established between architecture and the human body through anatomical illustrations, a more apparent case could be overviewed. The drawing from a Hebrew encyclopedia by the physician Toviya Kats (ca.1652–1729) directly paired the human viscera with the interior space of a building. In this metaphorical illustration, the organs of the body are shown as corresponding to the rooms in the building, each having a distinct function.

⁵¹⁹ Clare E. L. Guest, “Art, Antiquarianism and Early Anatomy,” *Medical Humanities* 40, no. 2 (2014): 97–104, <http://dx.doi.org/10.1136/%0Dmedhum-2013-010419>. 100



Figure 140. Anatomical illustration by Toviyah Kats (ca. 1652–1729) Venice, 1708.

Source: Michael Sappol, *Dream Anatomy* (Bethesda MD and Washington DC: US Dept. of Health and Human Services, National Institutes of Health, National Library of Medicine, 2006), 88

The term *fabrica* chosen for the title of *De Humani Corporis Fabrica libri septem*, the ancestor of the long-standing tradition of anatomical illustration, draws attention. The Latin word *fabrica* has multiple meanings. It refers to fabrication, constitution, construction.⁵²⁰ This shows the approach of Vesalius towards the human body. It is possible to infer that he considered the body as a construction, a designed structure, maybe even an architectural entity.

⁵²⁰ Ferreira, “Embodied Emotions: Observations and Experiments in Architecture and Corporeality.”

“In the humanist and Renaissance world the human body was, next to imaginary cities, a second "construction" (*fabbrica*) around which spectators could be organized within theatrical models that were consciously derived from ancient times...The fact that the human body was thought of, viewed and described in architectural terms has been remarked upon, and the terminological and cognitive relation between anatomy and architecture has been recognized.”⁵²¹

As stated by Ferrari, the togetherness of architectural artefacts with the anatomical figures in anatomical illustrations suggests the idea that human body was perceived as an architectural structure. The common use of Roman architecture in Renaissance anatomical illustrations made reference to the “notion of exemplarity”. This meant that the exemplar bodies were brought together with the exemplar architecture to justify the perfection of one another. This condition also underlined the fact that “behind the focus on canonical proportion in bodies and buildings lay the idea of the body/fabric as container or instrument for activity, conceived in the soul.”⁵²²

⁵²¹ Ferrari, “Public Anatomy Lessons and the Carnival: The Anatomy Theatre of Bologna.”

⁵²² Guest, “Art, Antiquarianism and Early Anatomy.” 101

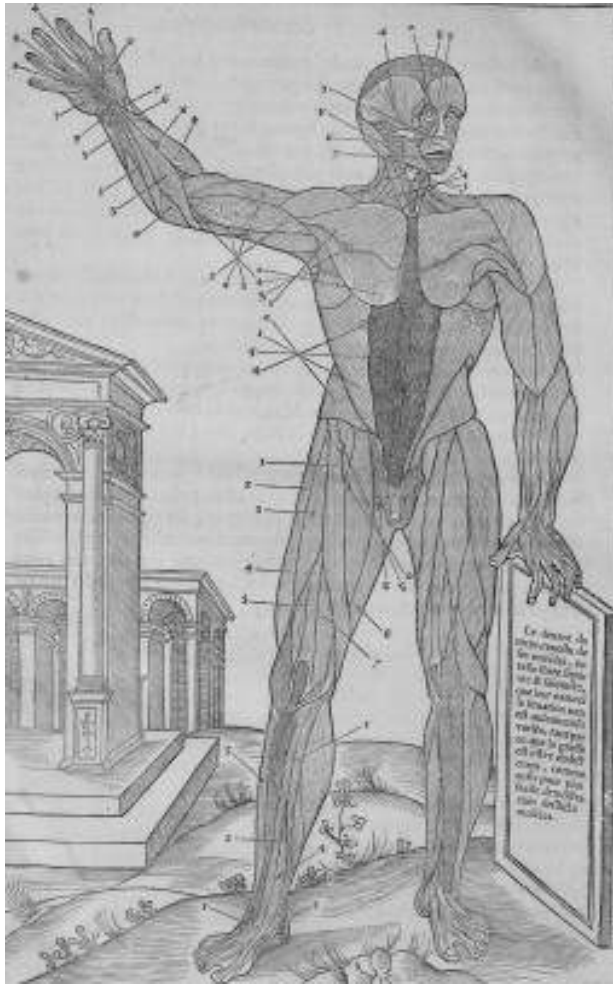

Figure 141. Illustration from *De dissectione partium corporis* by Charles Estienne, Paris, 1545. Colors edited by the author.

Source: Steffi Sams, “Charles Estienne - La Dissection Des Parties Du Corps Humain 1546,” accessed July 8, 2020, <https://www.rcseng.ac.uk/library-and-publications/library/blog/charles-estienne-la-dissection-des-parties-du-corps-humain-1546/>.

The illustrations of Pietro Berretini da Cortona (1618-1620) carries the relationship established between architecture and anatomical body to the next level in terms of depicting the contrast between interior and exterior and also rendering the “depth, volume and tangibility of the various elements of the illustrated body”⁵²³ in a masterful way. Another important aspect of Cortona’s drawings is that the way he

⁵²³ Ian Maxwell, “‘Who Were You?’ : The Visible and the Visceral,” in *Anatomy Live: Performance and the Operating Theatre*, ed. Maaike Bleeker (Amsterdam University Press, 2008), 49–66.58

situated the anatomical bodies next to columns which could be seen as a reference to the ancient Greeks' admiration of columns and the deep-rooted column-body analogy.

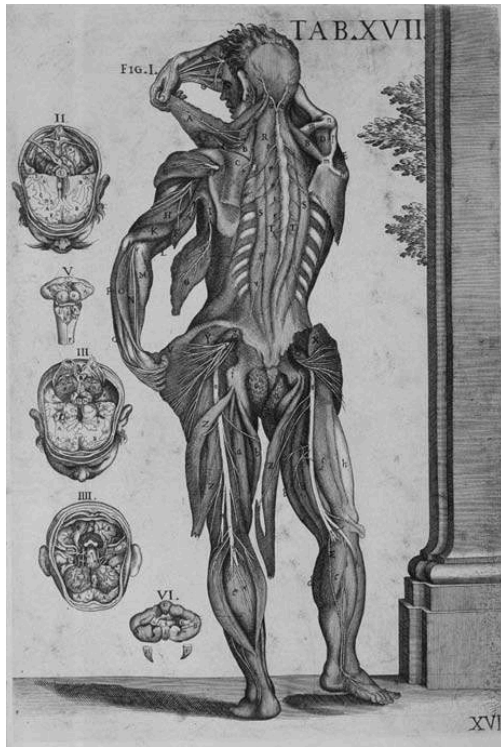

Figure 142. Illustration from Pietro da Cortona, *Tabulae Anatomicae* 1741. Plate XVII.

Source: Ian Maxwell, “Who Were You?” : The Visible and the Visceral,” in *Anatomy Live: Performance and the Operating Theatre*, ed. Maaïke Bleeker (Amsterdam University Press, 2008), 49–66, 58

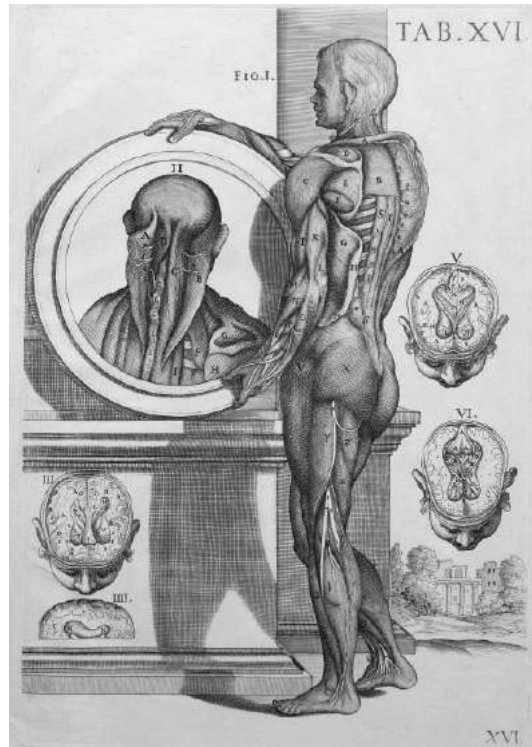

Figure 143. Illustration from Pietro da Cortona, *Tabulae Anatomicae* 1741. Plate XVI. Colors edited by the author.

Source: Michael Sappol, *Dream Anatomy* (Bethesda MD and Washington DC: US Dept. of Health and Human Services, National Institutes of Health, National Library of Medicine, 2006), 7

On the other hand, the state of the illustrated body, usually harmed through dissection and dismemberment, has been associated with the condition of the architectural entity in the drawing. It is possible that architectural representations portraying ancient ruins affected the evolving modes of anatomical representation showing different levels of the body such as bones, arteries, veins, nerves and muscles.⁵²⁴

⁵²⁴ Guest, “Art, Antiquarianism and Early Anatomy.” 100

Some of the illustrations from Charles Estienne's *De dissectione partium corporis* (On the dissection of the parts of the human body) published in 1545 epitomize this condition. (Fig. 144)

“Architectural influence also appears in the backgrounds of Renaissance anatomical illustration with their frequent allusions to decay and damage...in Estienne's *De dissectione* where dissected body parts appear among the carved and damaged marbles, Roman-style furnishings and waste-ground vegetation.”⁵²⁵

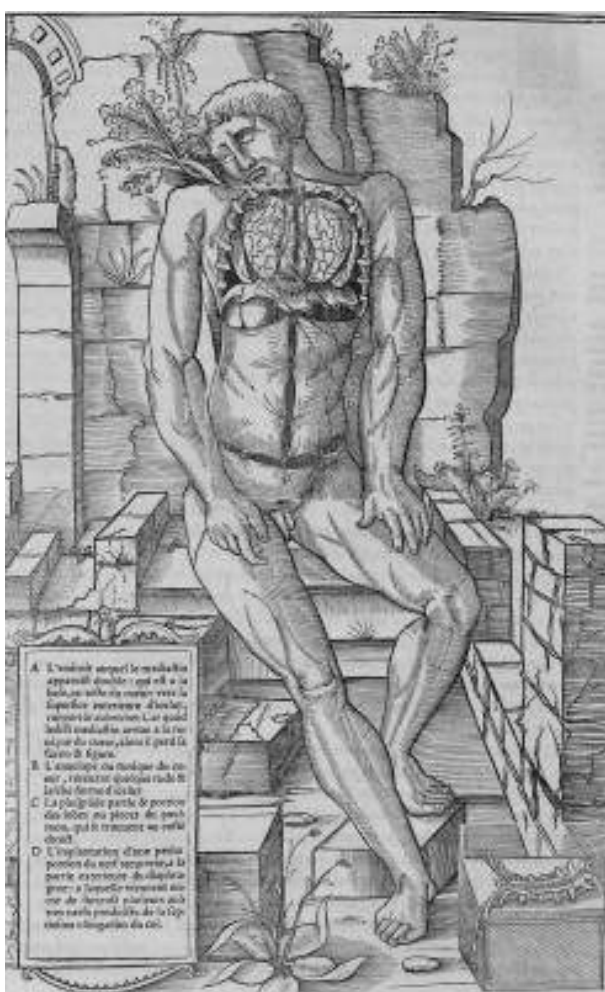

Figure 144. Illustration from *De dissectione partium corporis* by Charles Estienne, Paris, 1545. Colors edited by the author.

Source: Michael Sappol, *Dream Anatomy* (Bethesda MD and Washington DC: US Dept. of Health and Human Services, National Institutes of Health, National Library of Medicine, 2006), 97

⁵²⁵ Guest. 100

Another illustration from *De dissectione partium corporis* showing the brain structure presents an interesting condition. (Fig. 145) The male figure whose head was dissected to show the inner space of his brain would be death in normal conditions but his hand holds the legend of the marked brain parts which indicates that he is actually alive. This dual condition of the anatomical figure between life and death corresponds to the architectural structure at the background whose front façade in good condition with people standing above suggest that it is still in use while its side façade seems like a ruin covered with weed.

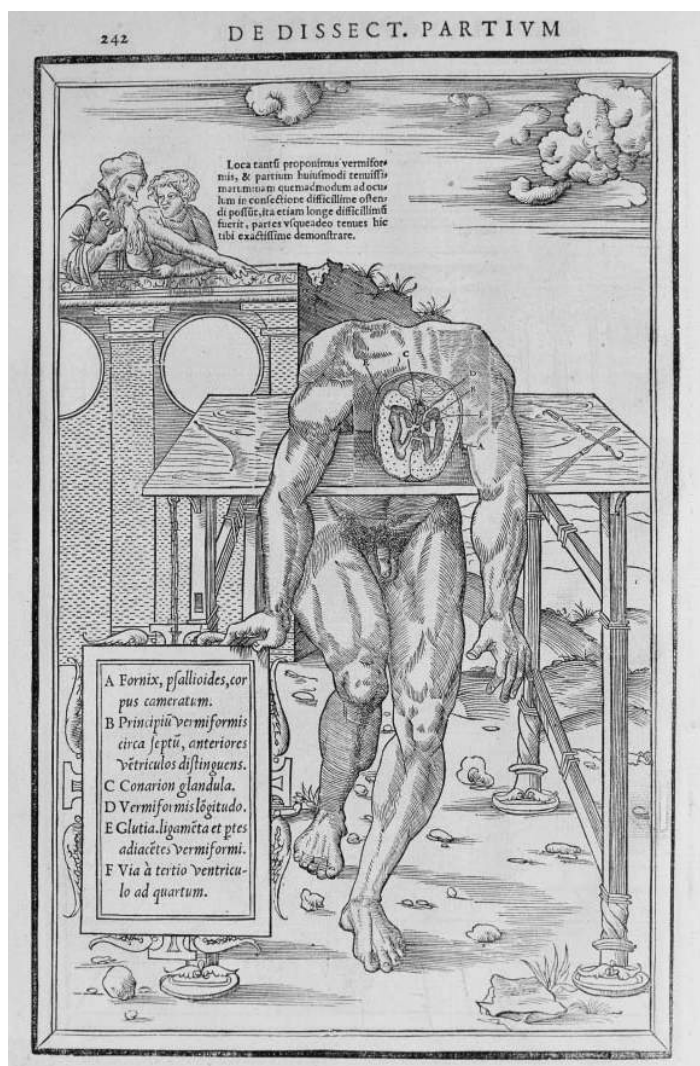

Figure 145. *De dissectione partium corporis* by Charles Estienne, Paris, 1545. Woodcut. National Library of Medicine. Colors edited by the author.

Source: Michael Sappol, *Dream Anatomy* (Bethesda MD and Washington DC: US Dept. of Health and Human Services, National Institutes of Health, National Library of Medicine, 2006), 95

In some illustrations it is possible to make more articulated inferences regarding the correspondence between the architectural elements and the anatomical figures. The drawing from *De dissectione partium corporis* portraying the anatomy of female genitalia includes a woman figure located in an interior space. By looking at the illustration, it is possible to say that the architectural setting shows the entrance of a building since an open door is shown at the back. The landscape surrounding the building and a façade is seen through the open door. Regarding that, it could be inferred that the space chosen as a background for this depiction is not coincidental as it suggests an association between the entrance space of a building and the vaginal opening of a female body.

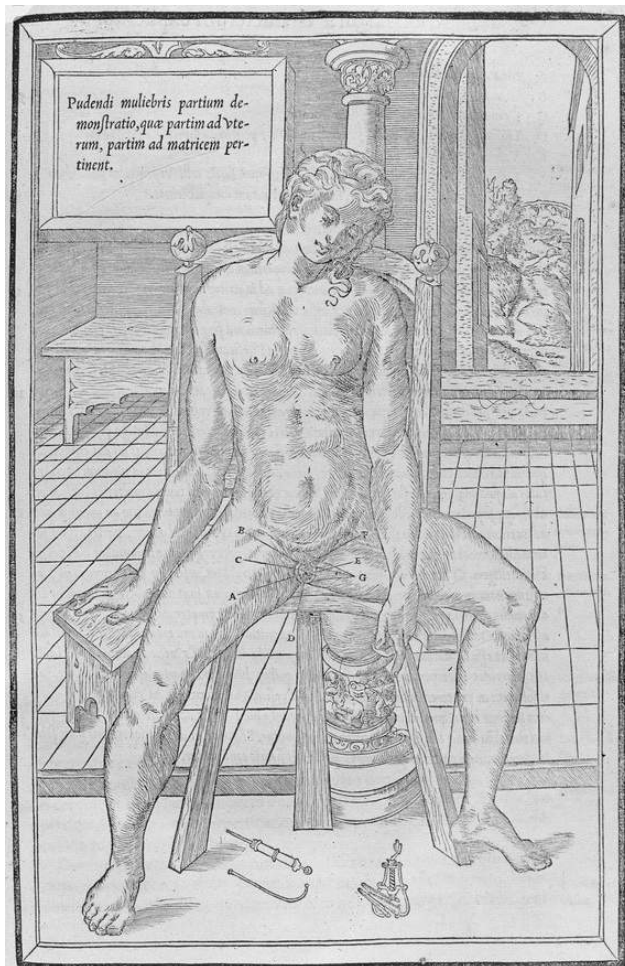

Figure 146. *De dissectione partium corporis* by Charles Estienne, Paris, 1545. Colors edited by the author.

Source: "Estienne: De Dissectione Partium Corporis," Wellcome Collection, accessed July 8, 2020, <https://wellcomecollection.org/works/hnvyp8zu>.

The relationship between the anatomical body and the surrounding environment was not limited to architecture, landscape was also considered in anatomical drawings. The architectural and landscape elements drawn as the background of the anatomical illustrations apparently reflect the idea that the human body was imagined as an architectural or landscape entity. Second plate of muscles in the second book of *De Humani corporis fabrica* embodies this argument: (Fig. 147)

“The backgrounds to the muscle men of *Fabrica* II form a continuous landscape frieze when shown in mirror image which implies they could be seen as actors in a larger history, as well as separate, serial figures. The landscape also becomes more depopulated, from townscape to scattered ruins to wasteland, mirroring the progressive dissection of the figures.”⁵²⁶



Figure 147. Second plate of the muscles from Vesalius, *De humani corporis fabrica*, 1543. Colors edited by the author.

Source: Clare E. L. Guest, “Art, Antiquarianism and Early Anatomy,” *Medical Humanities* 40, no. 2 (2014): 97–104, 99

⁵²⁶ Guest. 101

The presence of architectural and landscape elements in the anatomical illustrations was not just a Renaissance trend. Many anatomical drawings created during the 1800s and 1900s bore the traces of this approach. In some anatomical illustrations landscape set the background of the anatomical figures, while in some others, such as the engravings of Charles Bell and Fritz Kahn, the interior of the human body itself is depicted like a landscape scenery. (Fig. 148-149-150)



Figure 148. Plate II, “Nerves of the Neck,” from Charles Bell, *A Series of Engravings Explaining the Course of the Nerves* (1803).

Source: Carin Berkowitz, “The Beauty of Anatomy: Visual Displays and Surgical Education in Early-Nineteenth-Century London,” *Bulletin of the History of Medicine* 85, no. 2 (2011): 248–78, 258



Figure 149. Plate IV, an engraving of the arteries of the head, from Charles Bell’s *Engravings of the Arteries*.

Source: Berkowitz, 274



Figure 150. Source: A view from the interior of a nostril. Fritz Kahn, *Das Leben des Menschen*, Vol. 2. (1926)
Colors edited by the author.

Source: Michael Sappol, *Dream Anatomy* (Bethesda MD and Washington DC: US Dept. of Health and Human Services, National Institutes of Health, National Library of Medicine, 2006), 148

An important concept relating the body to architecture is the fact that both have been imagined and represented as machines or industrial equipment or settings throughout the centuries. Da Vinci created a machine-like analogy to indicate how the blood is pumped from the heart to the rest of the body. Descartes also depicted the human body as a machine in some of his sketches. His diagrammatic sketch of the translation of image from eye to brain is “the physiological equivalent of a camera obscura.”⁵²⁷

⁵²⁷ Sappol, *Dream Anatomy*. 42

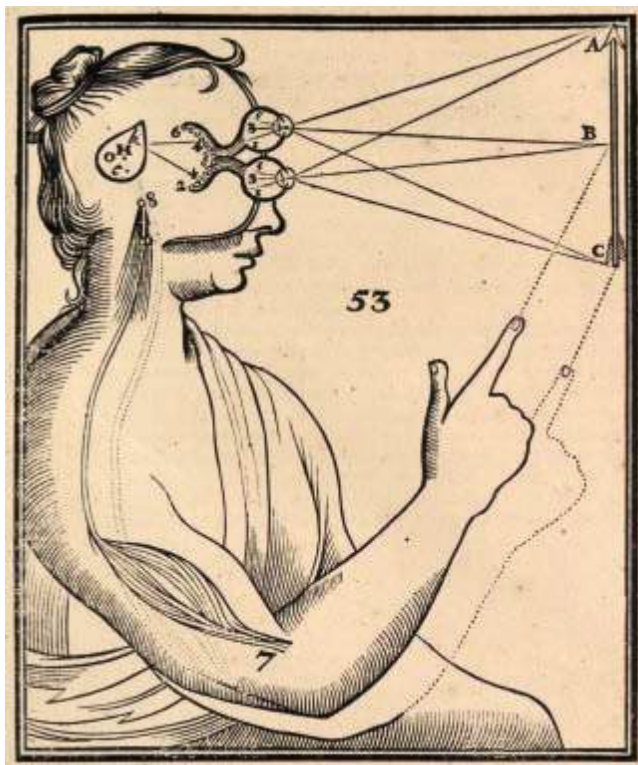

Figure 151. Diagram showing image translation from eye to brain. René Descartes, *Tractatus de homine, et de formatione foetus*, 1677.

Source: Michael Sappol, *Dream Anatomy* (Bethesda MD and Washington DC: US Dept. of Health and Human Services, National Institutes of Health, National Library of Medicine, 2006), 42

In the early 20th century, German physician Fritz Kahn who is known to be the father of modern infographics, created a series of books on the inner structure and functioning of the human body using “visual metaphors drawn from industrial society such as assembly lines, internal combustion engines, refineries, dynamos, telephones, etc.”⁵²⁸ The anatomical bodies in Kahn’s images were stylistically quite different from the Renaissance illustrations and the subsequent works that follow that tradition, they were “modern”, industrial, productive and highly functional. In that sense, it is possible to argue that Kahn put an emphasis on the function of the body parts rather than their morphological qualities.

⁵²⁸ Sappol. 144

The illustration by Kahn published in his book *Das Leben des Menschen* in 1926, showing the oxygen cycle in the body through a sectioned male figure draws attention. (Fig. 152) In the image, the organs and their connections are portrayed as if they were the spaces and equipment in an industrial plant, designed for the manufacturing, processing, storing and supply industrial materials. In their conversation with Michael Sappol, Eva Åhrén expresses her perception of the illustrations as “It rather makes me feel like I am (in) a building of some sort, with designated spaces for functional furniture, my organs.”⁵²⁹ The comment of Åhrén underlines concept of imagining the body as an architectural entity that comprises specialized spaces accommodating complex functions. Based on this illustration, Sappol calls the interior of the human body as a “strange space” and describes it as follows:

“The body is turned into a physiological flow chart or an architectural floor plan, a design - in a period when graphic design, industrial design and design aesthetics were being professionalized and institutionalized and celebrated as the most modern part of modernity.”⁵³⁰

⁵²⁹ Eva Ahren and Michael Sappol, “The Strange Space of the Body: Two Dialogues”, in *Strange spaces: Explorations into mediated obscurity*, eds. Jansson André and Amanda Lagerkvist (Farnham: Ashgate Publishing, 2009), 73-100. 85

⁵³⁰ Eva Ahren and Michael Sappol, “The Strange Space of the Body: Two Dialogues”, in *Strange spaces: Explorations into mediated obscurity*, eds. Jansson André and Amanda Lagerkvist (Farnham: Ashgate Publishing, 2009), 73-100. 75

DER KREISLAUF DES SAUERSTOFFS.

Was geht in dir vor, während du dieses Bild beschaust?

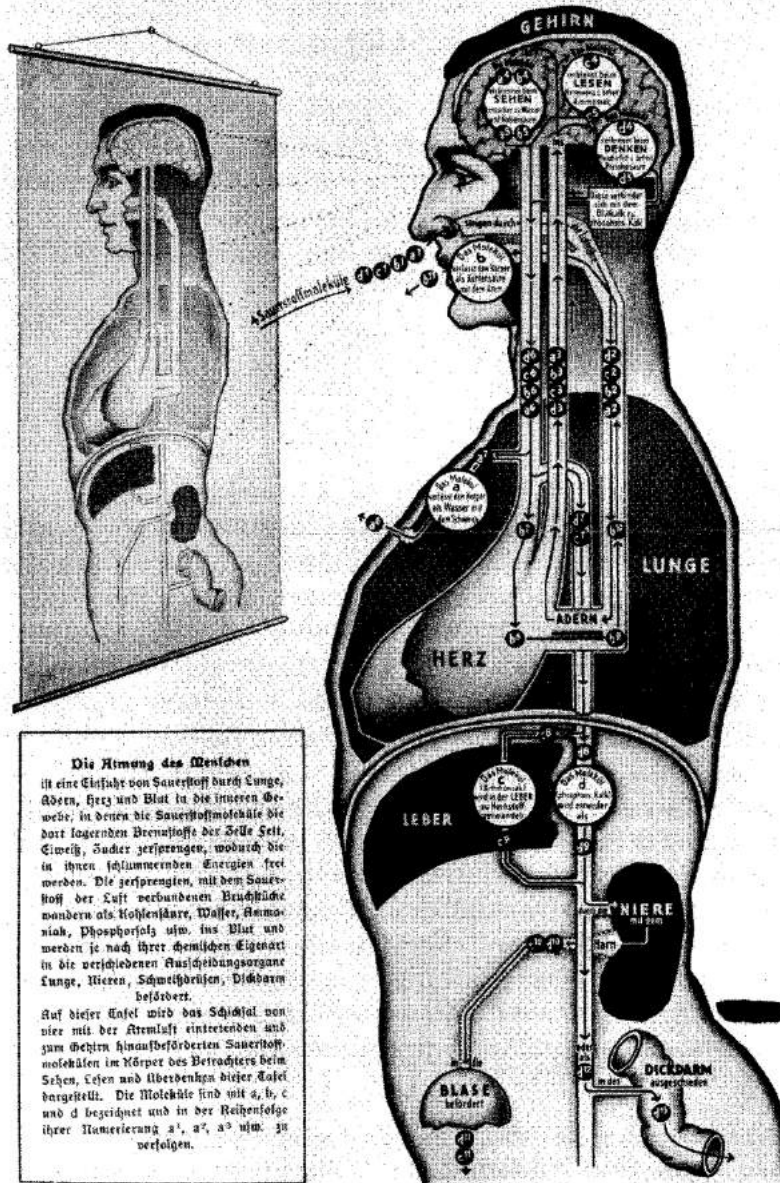

Figure 152. Fritz Kahn, “The Oxygen Cycle”, *Das Leben des Menschen: Volkstumliche Anatomie, Biologie, Physiologie und des Menschen*

Source: Eva Åhrén and Michael Sappol, “The Strange Space of the Body: Two Dialogues,” in *Strange Spaces: Explorations into Mediated Obscurity*, ed. Andre Jansson and Amanda Lagerkvist (Farnham: Ashgate Publishing, 2009), 73–100, 74

Another illustration by Kahn named *Der Mensch als Industripalast* (Human as Industrial Palace) provides a more complete depiction of the human body thought as an industrial space. (Fig. 153) The spatial quality of the viscera is emphasized by the inclusion of small human figures in various parts and organs of the body such as the head and the liver. This illustration emphasizes the complex activities that take place in the corporal space by relating them to the functioning of an industrial plant. Kahn produced other visuals focusing not on the entire but specific parts of it. For instance, Fig. 154 implies the idea that the human nervous system is imagined as an “electronic signaling system” since the brain is represented as “the office where the messages are sorted”.⁵³¹ In another image entitled *Biologie des Bratenduftes* (Biology of Frying/Roasting Smell) Kahn showed the head as an articulated space including distinct but connected “centers” that control the activities associated with the senses of smell, hearing and taste such as saliva and ear wax production based on the experience of smelling a frying/roasting. (Fig.155) Unlike the previous image depicting the brain as a part of an electronic signaling system, this illustration shows the brain as a center for remembering and reflexes.

⁵³¹ Sappol, *Dream Anatomy*. 144

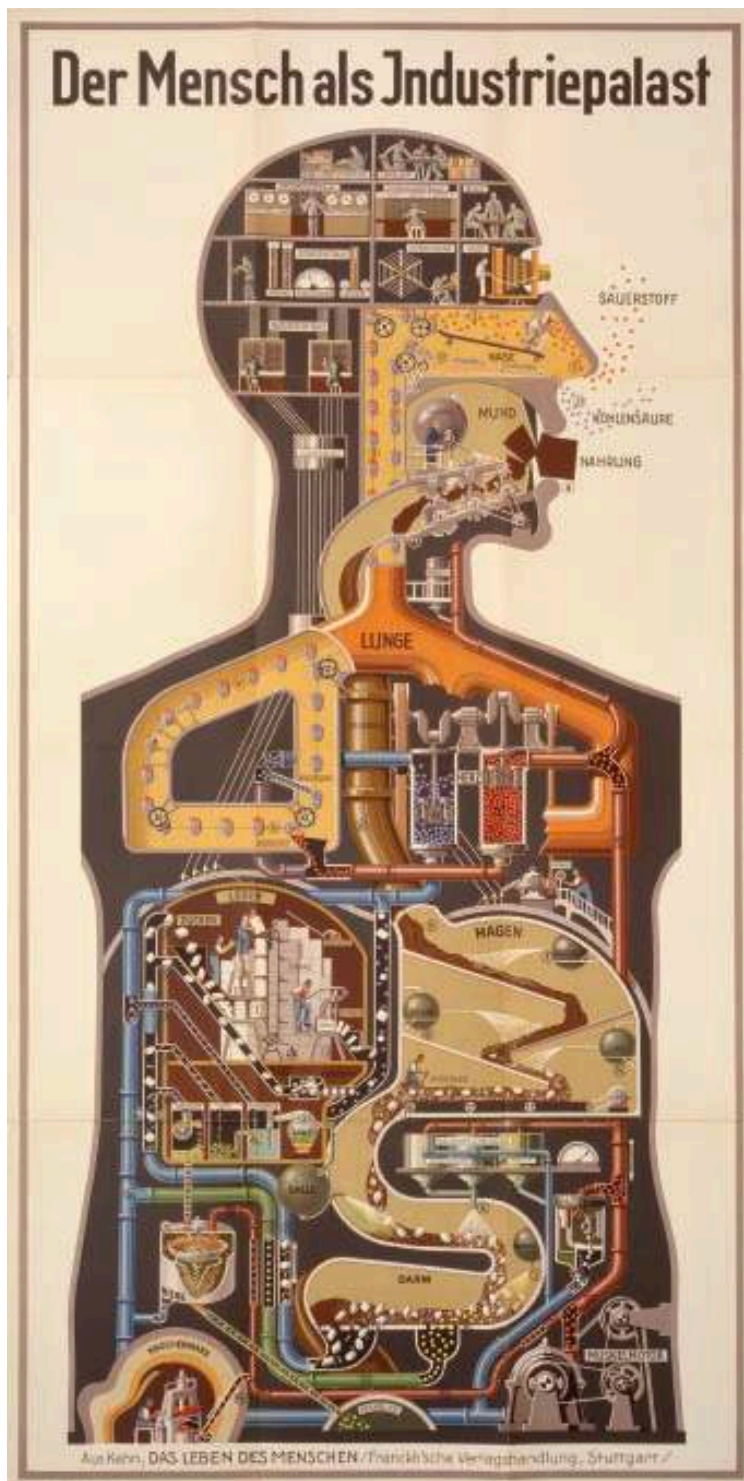

Figure 153. Fritz Kahn, *Der mensch als industriepalast*. Stuttgart, 1926.

Source: Michael Sappol, *Dream Anatomy* (Bethesda MD and Washington DC: US Dept. of Health and Human Services, National Institutes of Health, National Library of Medicine, 2006), 58

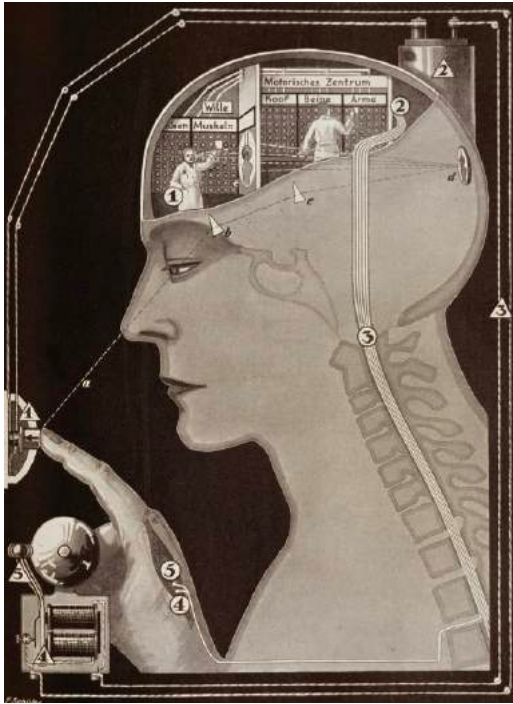

Figure 154. Fritz Kahn, *Das leben des menschen; eine volkstümliche anatomie, biologie, physiologie und entwicklungsgeschichte des menschen*. Vol. 2. Stuttgart, 1926. Tafel XIII.

Source: Michael Sappol, *Dream Anatomy* (Bethesda MD and Washington DC: US Dept. of Health and Human Services, National Institutes of Health, National Library of Medicine, 2006), 145



Figure 155. Fritz Kahn, *Das leben des menschen; eine volkstümliche anatomie, biologie, physiologie und entwicklungsgeschichte des menschen*. Vol. 2. Stuttgart, 1926. Tafel XV.

Source: Sappol, 168

During the 1920s, the architectural equivalent of the perception based on the consideration of human body as an industrial plant, a complex system of equipment and machinery has been created by the modernist architects. In 1923, Le Corbusier argued that “the house is a machine for living in.”⁵³² In parallel with the thinking of Fritz Kahn that consider the “body is a machine for living in”⁵³³. The undecorated and crisply legible illustrations of Kahn and the spaces of modern architecture

⁵³² Eva Ahren and Michael Sappol, “The Strange Space of the Body: Two Dialogues”, in *Strange spaces: Explorations into mediated obscurity*, eds. Jansson André and Amanda Lagerkvist (Farnham: Ashgate Publishing, 2009), 73-100. 85

⁵³³ Eva Ahren and Michael Sappol, “The Strange Space of the Body: Two Dialogues”, in *Strange spaces: Explorations into mediated obscurity*, eds. Jansson André and Amanda Lagerkvist (Farnham: Ashgate Publishing, 2009), 73-100. 85

resembled each other as they met on the common ground of function-prioritizing, rational way of seeing.

The phrase by Le Corbusier was introduced to the architectural discourse within his masterpiece “Towards a New Architecture” supporting his belief that “architecture should be designed in a way that refers to the engineers’ working methods in problem solving and that it should be designed in accordance to standards.”⁵³⁴ For Le Corbusier standard was defined by the functionality and the concept of “architecture as machine” referred to the acknowledgement of science and logic as a basis for architectural design. He underlined the design methods employed by the engineers based on the clear definition of the design problem and the logical problem solving and creation process, for the design of airplanes, automobiles and other machines and suggested the use of these methods in the design process of architecture.⁵³⁵ At this point, it is necessary to mention Le Corbusier’s project named Maison Citrohan, referring to *Citroen*, proposing the idea that the house should be designed and produced as automobiles and Fritz Kahn’s illustration of the human body depicting it as a submarine based on its floating ability. These striking examples support the argument that both the human body and architecture was imagined as machines. (Fig.156-157)

⁵³⁴ Paramita Atmodiwirjo and Yandi Andri Yatmo, “Architecture as Machine; Towards an Architectural System for Human Well-Being,” *Le Corbusier, 50 Years Later International Congress*, 2015, <http://dx.doi.org/10.4995/LC2015.2015.679>. 1

⁵³⁵ Le Corbusier. 1923/1946. *Towards a New Architecture*. London: Architectural Press. 10

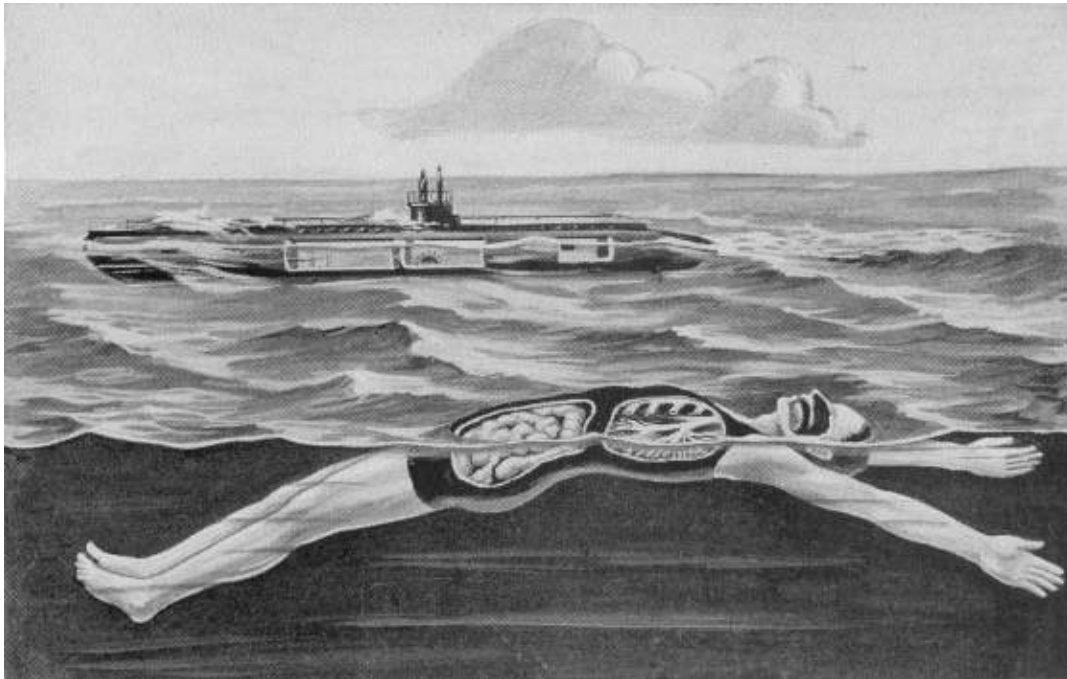

Figure 156. Fritz Kahn, *Man in Structure & Function*, Vol. 1. New York, 1943. Colors edited by the author.

Source: Michael Sappol, *Dream Anatomy* (Bethesda MD and Washington DC: US Dept. of Health and Human Services, National Institutes of Health, National Library of Medicine, 2006), 172

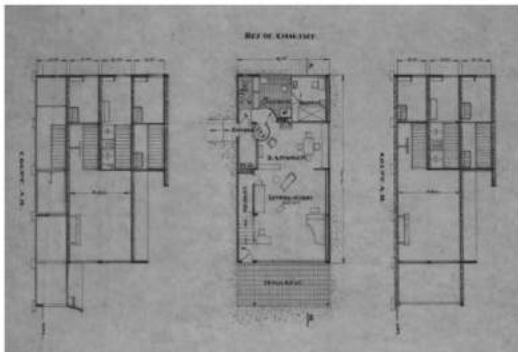

Figure 157. The model and plans of Maison Citrohan. Colors edited by the author.

Source: Paramita Atmodiwirjo and Yandi Andri Yatmo, "Architecture as Machine; Towards an Architectural System for Human Well-Being," *Le Corbusier, 50 Years Later International Congress*, 2015, <http://dx.doi.org/10.4995/LC2015.2015.679>, 4

In the “Manual of the Dwelling”, Le Corbusier underlined the important role of standards in architecture.⁵³⁶ In this manual he listed the main requirements of a functional and comfortable house that satisfies the essential needs of human dwelling. The primary concepts shaping the manual were comfort and health. For instance, the open plan concept which is considered to be as one of the signature statements of modern architecture allowing the sunlight and fresh air to freely enter and diffuse in the space appeared in the manual: “the house is only habitable when it is full of light and air.”⁵³⁷ In addition, the ergonomic design of the furniture that responds best to the limits and abilities of the human body was highlighted among the standards.

The perception of architecture as machine addressed not only the bodily comfort of the individuals but also public health issues. As Jasmine Rault wrote: “Le Corbusier’s famous machine a habiter was not only a machine for living in, but a technologically enhanced medical machine for healthier living.”⁵³⁸ Modern architecture was presented as a machine that could provide a new, hygienic living environment. The architectural elements associated with modern architecture such as flat roofs, terraces, balconies, in terms of providing direct access to light and air that were believed to be highly curative for certain diseases, especially for tuberculosis that deeply affected the society for decades - from the mid-nineteenth to the mid-twentieth century. As expressed by Margaret Campbell:

“Distinctive architectural features such as flat roofs, balconies and terraces were regarded as “modernist” through their association with “Modern Movement” and later “International Style” buildings. But, apart from popular architectural demands, why were flat roofs, balconies and roof or garden terraces found at latitudes and in climatic conditions that would normally be considered unsuitable for outside use? Not only did they satisfy

⁵³⁶ Le Corbusier, *Towards a New Architecture* (New York: Dover Publication, 1986). quoted in Atmodiwirjo and Yatmo, “Architecture as Machine; Towards an Architectural System for Human Well-Being.” 4

⁵³⁷ Corbusier, *Towards a New Architecture*. quoted in Atmodiwirjo and Yatmo, “Architecture as Machine; Towards an Architectural System for Human Well-Being.” 5

⁵³⁸ Jasmine Rault, *Eileen Gray and the Design of Sapphic Modernity: Staying In*. (Surrey: Ashgate Publishing, 2011). 34 quoted in Atmodiwirjo and Yatmo, “Architecture as Machine; Towards an Architectural System for Human Well-Being.” 5

a desire to acquire a fashionable suntan and reveal avant-garde architectural taste; their other, and less attractive, purpose was for the treatment of pulmonary tuberculosis.”⁵³⁹



Figure 158. Some features of modern architecture that promote human comfort and health, Villa Savoye by Le Corbusier. Colors edited by the author.

Source: “Villa Savoye,” accessed July 8, 2020, <http://www.fondationlecorbusier.fr/corbuweb/default.aspx>.

Within this context, the concern of Le Corbusier towards the importance of establishing an architecture system that could promote human comfort and healthy living focused on the climatic effects of the surrounding environment on architectural spaces and reflected in his sketches and diagrams. (Fig. 159)

⁵³⁹ Margaret Campbell, “What Tuberculosis Did for Modernism: The Influence of a Curative Environment on Modernist Design and Architecture,” *Medical History* 49 (2005): 463–88, <https://doi.org/10.1017/S0025727300009169>. 464-465

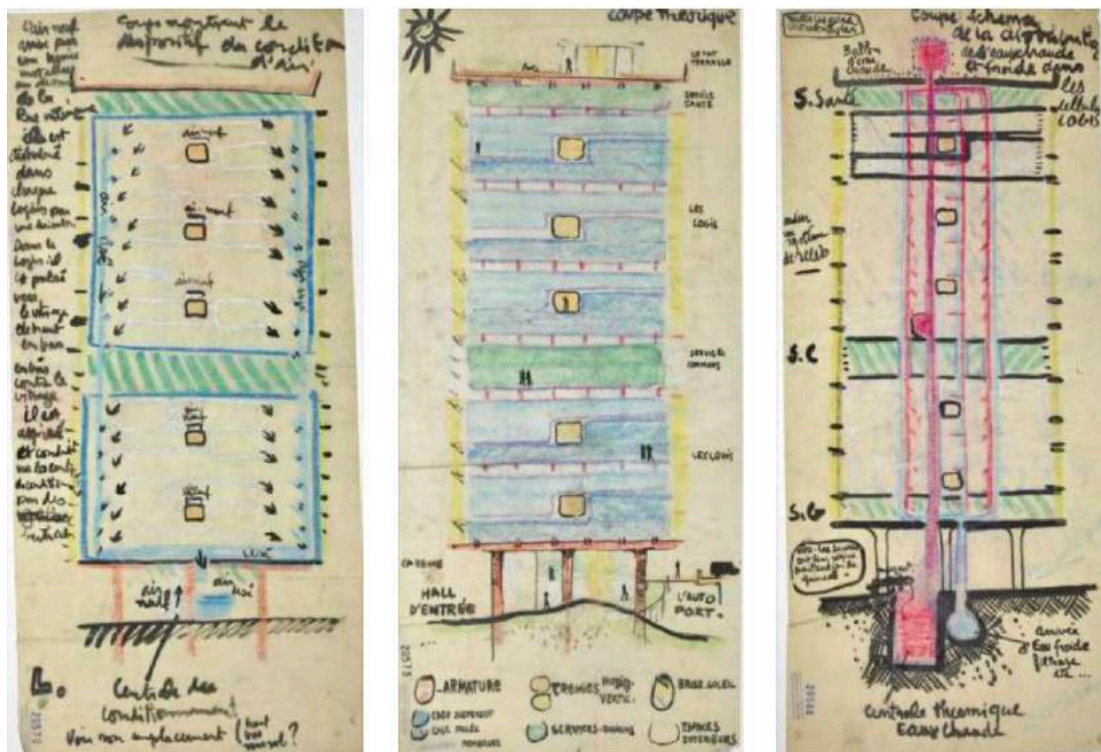

Figure 159. Analytical diagrams of Unite d'Habitation showing concern towards human comfort, Le Corbusier
 Source: Paramita Atmodiwirjo and Yandi Andri Yatmo, "Architecture as Machine; Towards an Architectural System for Human Well-Being," *Le Corbusier, 50 Years Later International Congress*, 2015, 7

In fact, the idea of considering architecture as machine was not only suggested by Le Corbusier. Many different theoretical and practical works in architecture and other related disciplines have employed machine-related concepts such as Felix Guattari's "desiring machine"⁵⁴⁰, Libeskind's "reading, memory and writing machines"⁵⁴¹. Some works brought the mechanical thinking in architecture to the next level by exploring the concepts of mechanics and appliances in depth and theorizing them such as Nicholson's "appliance house"⁵⁴² and Reyner Banham's idea of "house as an ensemble of mechanical gadgetry"⁵⁴³. All these works center around the idea of machine comprising "the mechanisms of interface, complexity and causality, and

⁵⁴⁰ Felix Guattari, "On Machines," *Journal of Philosophy and the Visual Arts* 6, no. 8 (1995): 8–12.
⁵⁴¹ Ersi Ioannidou, "Humanist Machines: Daniel Libeskind's 'Three Lessons in Architecture,'" in *The Humanities in Architectural Design A Contemporary and Historical Perspective*, ed. Soumyen Bandyopadhyay et al. (Abingdon: Routledge, 2010).
⁵⁴² Ben Nicholson, *Appliance House* (Chicago Institute for Architecture and Urbanism, 1990).
⁵⁴³ Reyner Banham, "A Home Is Not a House," *Art in America*, no. 2 (1965).

therefore it provokes some critical ways of comprehending the relationship between elements involved in a system.”⁵⁴⁴

At this point, it becomes relevant to elaborate on Reyner Banham’s 1965 dated highly influential essay “A Home is Not a House”. In this essay, Banham stresses the significance of the mechanical, electrical and plumbing systems of a house, even considers them as the defining elements of a dwelling unit. The essay eschewing a formal narrative begins as follows:

“When your house contains such a complex of piping, flues, ducts, wires, lights, inlets, outlets, ovens, sinks, refuse disposers, hi-fi re-verberators, antennae, conduits, freezers, heaters -when it contains so many services that the hardware could stand up by itself without any assistance from the house, why have a house to hold it up. When the cost of all this tackle is half of the total outlay what is the house doing except concealing your mechanical pudenda from the stares of folks on the sidewalk?”⁵⁴⁵

The image included in the essay named as “Anatomy of a Dwelling” created by designer François Dallegret clearly embodies the powerful idea of Banham.(Fig.160) The illustration depicting a dwelling that is reduced to its mechanical systems, without its exterior shell which is considered to be the most distinctive quality of a building was described as “baroque ensemble of domestic gadgetry” by Banham.⁵⁴⁶

Summarizing the machine analogy in architecture, established as a part of modernist thinking, Anthony Vidler wrote:

“The functional analogies of modernism theorized the building as a 'machine for living in', with the implication that a smoothly running machine, tailored to the body's needs, was modernity's answer to the proportional and spatial analogies of humanism.”⁵⁴⁷

⁵⁴⁴ Atmodiwirjo and Yatmo, “Architecture as Machine; Towards an Architectural System for Human Well-Being.” 2

⁵⁴⁵ Banham, “A Home Is Not a House.”

⁵⁴⁶ Banham.

⁵⁴⁷ Vidler, “The Building in Pain: The Body and Architecture in Post-Modern Culture.” 8

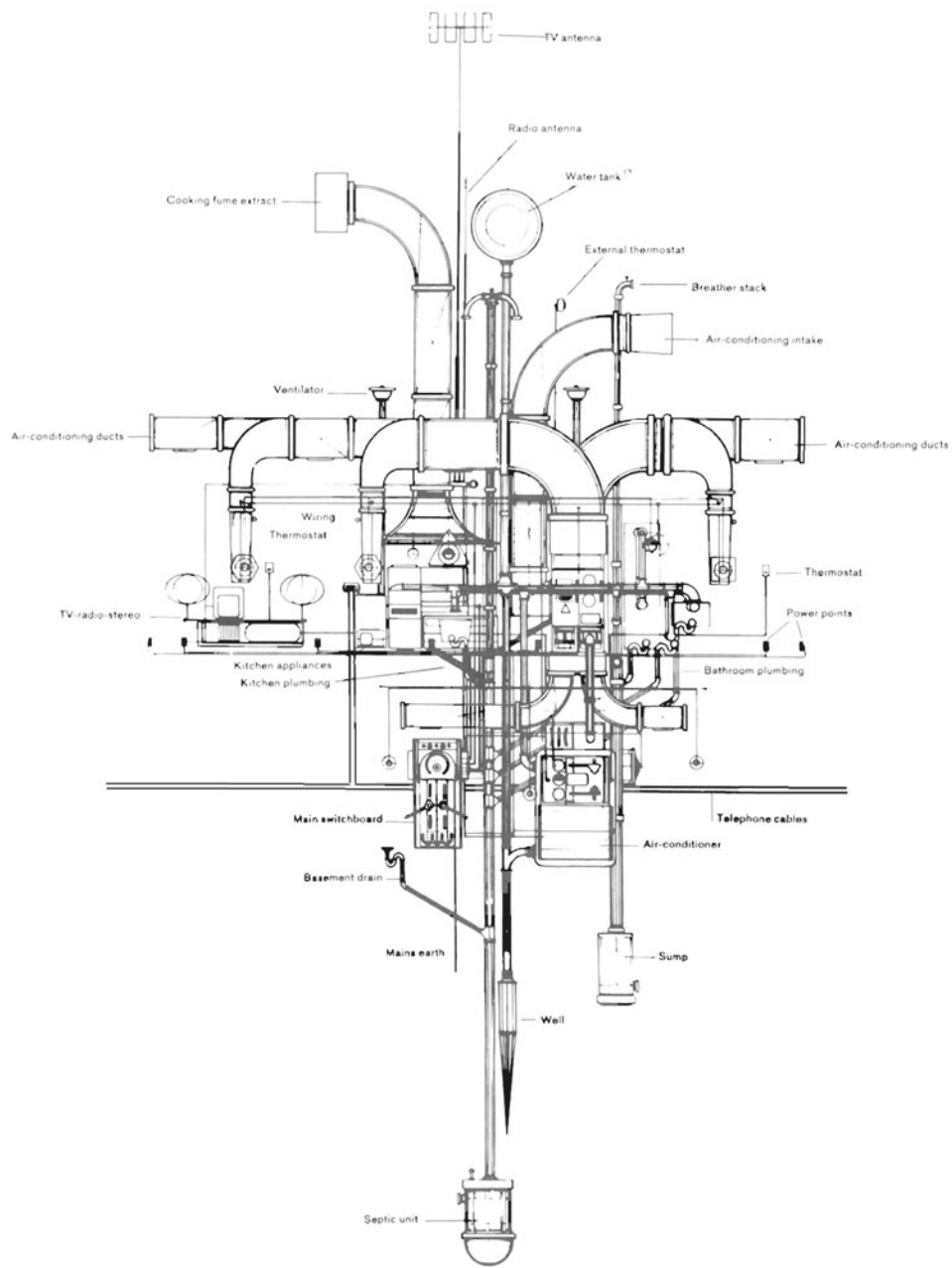

110

Figure 160. Anatomy of a Dwelling by François Dallegret

Source: Reyner Banham, "A Home Is Not a House", *Art in America*, no.2 (1965)

4.2.3. Spatialization of the Body in Museum Space

Within the scope of this thesis, after analyzing the spatial links between architecture and the body in a broader context, it is necessary to put a special focus on anatomy museums and explore the ways that the anatomical body is related to the display space.

In anatomy museum the elements retrieved from different “bodies” are gathered and displayed together. Brain diagrams, heart models, skin photographs and intestine specimens in jars... In the museum space the “real” body pieces from dissected and dismembered bodies are disposed together with their two or three dimensional representations created in various media. The display of the anatomical body is through dissection and dismemberment. As the body is dissected and dismembered for display purposes, the occurrence of display depends on the operations of cutting and disassociating. In this context, it is possible to think that the space of display, especially the anatomy museum, is the reason why the bodies are dissected and dismembered. In better terms, body is dissected and dismembered *by* the space of the museum.

The perfectly enclosed and intact body opens up and blends into the space. The body loses its organic character and transforms into a display object and becomes a part of the museum space. The term spatialization means “the process of causing something to occupy space or assume some of the properties of space”⁵⁴⁸. Therefore, this study argues that the body spatializes in the space of the anatomy museum.

Within this context it is necessary to mention the concept of “regional display” which refers to the “arrangement of the museum space as an anatomical body”⁵⁴⁹. In this case, the anatomy museum space is divided into the same anatomical regions as the bodies in the dissecting room, so that its very structure materialized the divisions

⁵⁴⁸ “Spatialization,” in *Collins Dictionary*, accessed July 8, 2020, <https://www.collinsdictionary.com/dictionary/english/spatialization>.

⁵⁴⁹ Hallam, *Anatomy Museum: Death and the Body Displayed*. 85

apparent in dissections, prosections and anatomy textbooks. The parts of body such as upper limb, lower limb, thorax, abdomen, head and neck are assigned to the subdivided spaces of the museum. In better terms, the body is mapped onto the museum space through regional display. The condition of subspaces linked together with the body pieces presents a quite special case regarding the concept of the “spatialization of the body”. In this case the dismembered body not only expands into the museum space but also specifically relates itself with certain subspaces.

An important characteristic of regional displays is their rich composition. Each section devoted to a region of the body features specimens, images, models in different media clustered together to show that specific part at diverse angles and depths and in varying levels of detail.⁵⁵⁰ As the display objects are not arranged according to their media but to their content, each region becomes a good implementation of the highly favored “intermedial display”, thus contributes to the concept of “multimedia mapping of the body”.

Displaying anatomy within regional structure is not uncommon. The University of Glasgow’s Museum of Anatomy, the Anatomical Museum at the University of Edinburgh and the Anatomy Museum at Marischal College have regional displays.⁵⁵¹ The regional display of the Anatomy Museum at Marischal College is described by Hallam as follows:

“In the Anatomy Museum at Marischal College the regional organization of material, unlike the historical exhibit in the museum’s gallery, was not concerned with chronology or numerical sequence, even though some objects were dated and numbered. Instead material was loosely arranged and rearranged on (adjustable) shelves within the appropriate region. The *Head and Neck* bay, in 1999, for instance, held preserved skulls, wax models of the inner ear, diagrams and specimens of teeth, a plaster model of the head showing the muscles, brain and eye, and a dissection of the head showing the nerves accompanied by a labelled photograph of the same specimen. Multiple renderings of the same parts offered elucidation through reiteration and shifts in scale, focus and orientation.”⁵⁵²

⁵⁵⁰ Hallam. 84

⁵⁵¹ Hallam. 83

⁵⁵² Hallam. 85



Figure 161. Regional display in Anatomy Museum in the Anatomy Department, Marischal College

Source: Elizabeth Hallam, *Anatomy Museum: Death and the Body Displayed* (London: Reaktion Books, 2016), 83



Figure 162. Regional display in the Museum of Anatomy, University of Glasgow, 2007

Source: Hallam, 83

It is possible to consider Corpus Museum in Netherlands as a literal interpretation of the concept “spatialization of the body”. The *museum*⁵⁵³ makes it physically possible to walk inside the human body. Different from the regional display where a “generic” museum space is divided into the regions of the body and each section is filled with a great variety of display objects corresponding to that certain part of the body, Corpus represents the human body through its architectural form and interior design. Canadelli describes the interior space of Corpus as follows:

“Transported on an escalator, visitors enter from the knee and ascend through the body until reaching the brain, where, comfortably seated and thanks to screens and panels, they can assist to the crackling functioning. of neurons. Between the two extremities they pass by displays and videos on digestion, the intestine, the heart, the lungs, the ears, learning what happens inside the body in daily and normal situations, like when we digest a cheese sandwich, when we sneeze or taste sweet or salty foods on our tongue. One of the central themes of this type of museum, reproduction, is here treated in the Uterus Theater, which is reminiscent of the secret cabinet of the 19th century, where a 3D cartoon on the fertilization of an egg cell by sperm cells is projected.”⁵⁵⁴

As expressed by Canadelli, through the projections on screens and panels, not only the form but also the functions of the corporal space are displayed. Although the architecture of Corpus remains static, thus incapable to express the complex functioning of the body, the video shows compensate for the incompetence of mere architecture to represent the space of the body in a complete manner which could be considered as a positive virtue.

⁵⁵³ Although referred to as a “museum”, Corpus fails to correspond to the museum definition by ICOM as explained in Chapter 2.1.2 .

⁵⁵⁴ Canadelli, “‘Scientific Peep Show’: The Human Body in Contemporary Science Museums.” 181

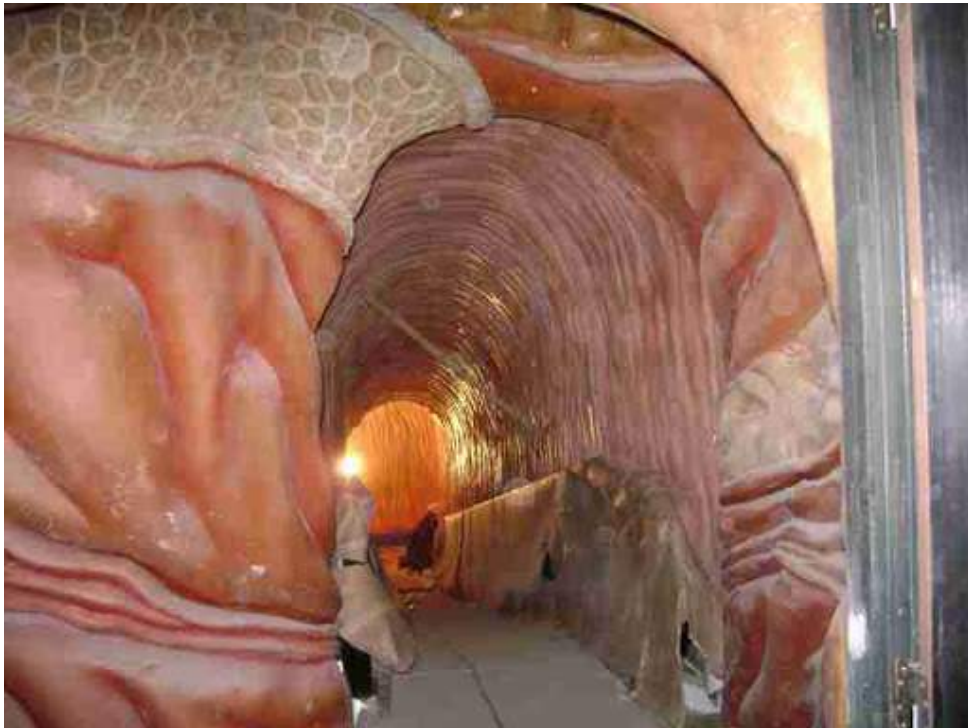

Figure 163. Interior of Corpus Museum, Oegstgeest

Source: "Corpus Museum Netherlands," accessed July 8, 2020,
http://www.themebuilders.biz/projects/corpus/corpus_gallery04.html.

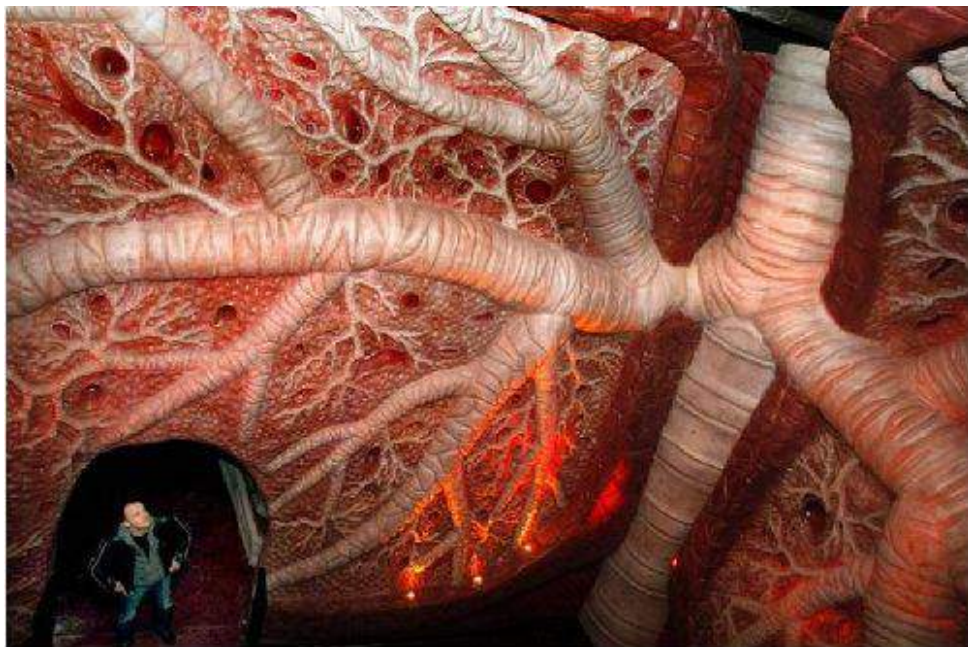

Figure 164. Interior of Corpus Museum, Oegstgeest

Source: "Body Museum," Pinterest, accessed July 8, 2020,
<https://www.pinterest.com.au/pin/68609594298677242/>.

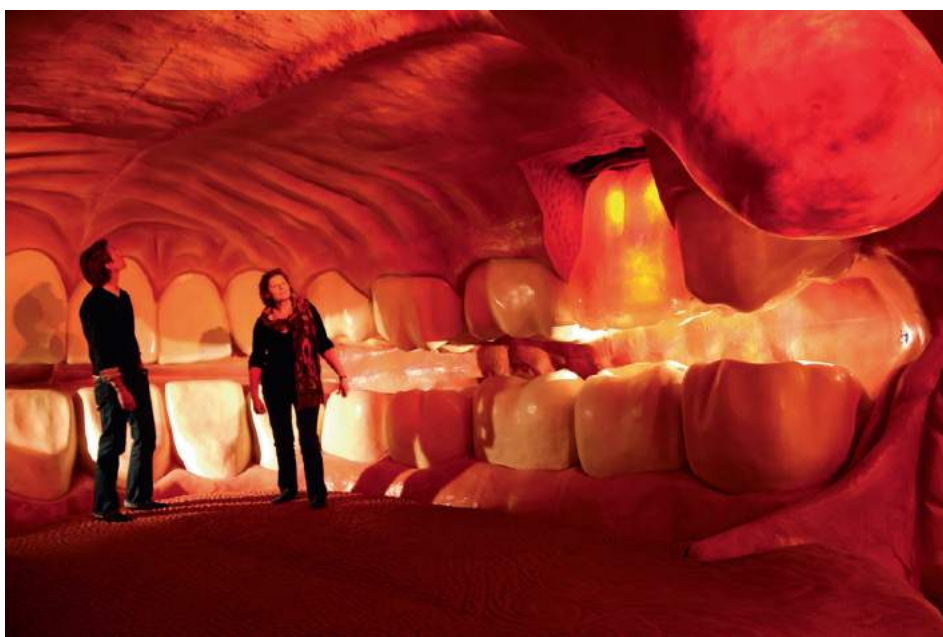

Figure 165. Mouth section of, Corpus Museum, Oegstgeest

Source: Elena Canadelli, “‘Scientific Peep Show’: The Human Body in Contemporary Science Museums,” *Nuncius* 26, no. 1 (2011): 159–84, 182

4.3. Transparency

4.3.1. The Visible Invisible⁵⁵⁵

“Many pursuits of knowledge about nature are conducted under the simple claim made by the Greek philosopher Heraclitus: ‘Nature loves to hide’”⁵⁵⁶

The idea that nature is hidden, not visible to the eye, dates back to the ancient Greece. As clearly expressed by Heraclitus, obscurity has been believed to be an essential quality of nature. This thinking directly applies to the human body. The human body, by nature, is self-enclosed and this condition denotes the fact that the body has an inside and an outside. Although the body tends to be perceived as an object in space,

⁵⁵⁵ Foucault, *The Birth of the Clinic: An Archaeology of Medical Perception*.

⁵⁵⁶ Ron Broglio, “Meat Matters,” in *Antennae*, ed. Giovanni Aloï, 2010, 58–71.59

the interior of the body is inaccessible to the bodily senses, especially to the sense of sight. The complex interiors of the body are hidden from view.

“[t]he invisibility of the eye within its own visual field, the diaphanous embodiment of language, the inaccessibility of the visceral organs: these all exhibit their own principles of absence, which can only be teased apart by a careful investigation.”⁵⁵⁷

As written by Drew Leder, the difficulty of the body to perceive its own interior space declares its obscurity. The interior space of the body is almost completely covered with an homogenous and opaque surface, the skin. Sappol sets forth this condition as “[t]he interior of our bodies is hidden to us. What happens beneath the skin is mysterious, fearful, amazing.”⁵⁵⁸ The skin is the threshold between the visible and the invisible.

“Inquiry from the Greeks on has taken Heraclitus' phrase as impetus to lift the veil on nature and reveal what has been kept hidden from us...cutting animals open serves as one way of lifting the veil, exposing the interiors as visually accessible exteriors.”⁵⁵⁹

As discussed in detail in Chapter 4.4.1, the primordial way to reveal the concealed interiors of the body is to cut up. In this context, the phrase “lifting the veil” is highly used by many philosophers and scholars. The act of disclosing the viscera of the body through dissection is described through the metaphor of “lifting the veil.” In his masterpiece *Faust*⁵⁶⁰, Goethe (1749-1832) also refers to the hiddenness of nature by employing the concept of “veil” in a metaphorical way:

“We snatch in vain at Nature's veil,
She is mysterious in broad daylight,

⁵⁵⁷ Drew Leder, *Absent Body* (University of Chicago Press, 1990). quoted in Maxwell, “‘Who Were You?’ : The Visible and the Visceral.”⁶¹

⁵⁵⁸ Sappol, *Dream Anatomy*. 288

⁵⁵⁹ Broglio, “Meat Matters.” 59

⁵⁶⁰ The tragic play written by Johann Wolfgang von Goethe in two parts. Part One was first published in 1808 and Part Two in 1832.

No screws or levers can compel her to reveal

The secrets she has hidden from our sight.”⁵⁶¹

Goethe has a different point of view on this issue. For him, nature is already visible but humans “do not have a mind that can see her.”⁵⁶² As Hadot wrote, “her real veil consists in having no veil. In other words, she hides because we do not know how to see her, although she is right before our eyes.”⁵⁶³ It is possible to say that Goethe considered the concepts of visibility and knowability separately. While dissection uncovers the invisible, to render it visible and intelligible, Goethe argued that the nature is already apparent though remains hidden, “unknowable” to us. On the other hand, Foucault underlines the relationship between “seeing and knowing,” that for him, constituted the basis of the transition from the mindset of the Enlightenment to the mindset of the nineteenth century. In this context, it is possible to interpret that what Goethe meant by “sight” was the mere act of “seeing,” not an advanced one. As explained in Chapter 2.2.1, the concept of “medical gaze,” introduced by Foucault, suggested a complex sense, beyond just seeing. Therefore, it could be said that relationship between visibility and knowledge is established at an advanced level of “seeing.” The act of cutting, by itself is not directly associated to knowing, what makes dissection a knowledge-related action is a sophisticated form of seeing, the “medical gaze,” behind it. In that sense, “lifting the veil” of the body through cutting reveals the knowledge of the body that is hidden inside.

The perfectly finished and integrated look of the body might create a deceptive impression since beneath the seamless layer of the skin, there lies a complex network of tissues, organs and systems. This is not only a corporeal network but also a multi-nodal web of knowledge containing a massive amount of scientific, socio-cultural and historical information. Within this framework, the body could be defined as

⁵⁶¹ Johann Wolfgang von Goethe, *Faust: Part One*, trans. David Luke (New York: Oxford University Press, 1998) quoted in Maxwell, “Who Were You? : The Visible and the Visceral.”⁶⁹

⁵⁶² Maxwell.⁶⁹

⁵⁶³ Pierre Hadot, *The Veil of Isis: An Essay on the History of an Idea*, trans. Michael Chase (Cambridge, MA: Belknap Press, 2006) quoted in Maxwell.⁶⁹

“visible invisible”⁵⁶⁴ which refers both to the “visibility” of the body as a physical entity, and the “invisibility” of its interiors comprising all the corporeal knowledge, waiting to be revealed through dissection performed under the medical gaze.



Figure 166. A wax Anatomical Venus shown intact and partially dissected, made in Rudolph Pohl workshop in Dresden, Germany, circa 1930. Courtesy the Münchner Stadtmuseum, Sammlung Puppentheater/Schaustellerei, Munich.

Source: Hunter Oatman-Stanford, “Sacred Anatomy: Slicing Open Wax Women in the Name of Science and God,” accessed July 8, 2020, <https://www.collectorsweekly.com/articles/sacred-anatomy/>.

⁵⁶⁴ The phrase introduced in Foucault, *The Birth of the Clinic: An Archaeology of Medical Perception*. Then also used in Bruno, *Public Intimacy: Architecture and the Visual Arts*.

4.3.2. Invisible Made Visible in Museum Space

“According to the dictionary definition, the quality, or state, of being transparent is both a material condition -that of being pervious to light and air - and the result of an intellectual imperative, of our inherent demand for that which should be easily detected, perfectly evident, and free of dissimulation.”⁵⁶⁵

Colin Rowe and Robert Slutzky in their article on “transparency” argue that there are two kinds of transparency: literal and phenomenal. Literal transparency is a perceptual quality as it engages the eye. Phenomenal transparency, on the other hand, is a conceptual condition engaging the mind of the viewer. In better terms. Literal transparency is a transparency of “looking”, whereas phenomenal transparency is a transparency of “reading”.⁵⁶⁶ The concept of transparency is quite important within the context of anatomy museum and it is possible to experience both kinds of transparency in the museum space.

The human body is covered with skin which is an opaque and continuous surface, hiding its complex interiors. In the anatomy museum, the images, models, photographs and specimens on display, make the bodily interior visible. In that sense, the anatomical displays produced in different media render the opaque body transparent in terms of providing the opportunity to see the interior of the body without performing a dissection. The museum display “renders the [body] transparent for the exercise of the mind.”⁵⁶⁷ In other words, when the bodily interiors are revealed in the anatomy museum, the anatomical knowledge is revealed as well. The strong connection between knowledge and visibility in the museum space exemplifies the phenomenal transparency.

The invention of Perspex glass and the manufacturing of Perspex display cases in the 19th century, the use of see-through materials such as translucent threads and

⁵⁶⁵ Rowe and Slutzky, “Transparency: Literal and Phenomenal.” 45

⁵⁶⁶ Rowe and Slutzky.

⁵⁶⁷ Foucault, *The Birth of the Clinic: An Archaeology of Medical Perception*, xiii.

colorless preserving liquids for specimens dramatically transformed the visual quality of the anatomy museums. Today, the anatomy museums are packed with glass jars, display cases and cabinets. Unadorned glass containers, lacking opaque, mostly wooden, frames and decorative elements, allow the uninterrupted viewing of anatomical objects. These glass containers are both literally and phenomenologically transparent. The optical clarity provided by the glass in terms of enhancing the visual experience of the viewer creates literal transparency.



Figure 167. Museum technician making transparent Perspex cases for specimens at the Royal College of Surgeons of England, c.1960

Source: Elizabeth Hallam, *Anatomy Museum: Death and the Body Displayed* (London: Reaktion Books, 2016),330

Like a “transparent veil revealing the whole and the relations between the parts,”⁵⁶⁸ the glass display cases expose the hidden interiors of the body, thereby disclose the anatomical knowledge. This condition indicates the phenomenological transparency offered by the display cases in the anatomy museum. In addition, the opaque, thick, material body parts displayed in the museum are related to each other through the glass containers. The overlapping, interpenetrating and superimposing of the objects representing the body, that occur by means of transparent containers suggest a particular reading, contemplation and interpretation of the anatomical material. Display objects inside glass cabinets aligned in rows along the museum space, create thick layers of information enveloping each other and this spatial setting produces the anatomical knowledge. As Gyorgy Kepes claims “[t]ransparency means a simultaneous perception of different spatial locations. Space not only recedes but fluctuates in a continuous activity.”⁵⁶⁹ In this framework, it is possible to say that transparency implies something more complex than mere optical effects. It is beyond the interpenetration of transparent objects without optical destruction, it is a spatial condition. The overlapping and interlacing of objects in the three-dimensional setting of the anatomy museum engenders an ambiguous and seminal context that enhances the anatomical scholarship.

⁵⁶⁸ Xavier Bichat, “A Treatise on the Membranes in General, and on Different Membranes in Particular,” (1813) quoted in Foucault, *The Birth of the Clinic: An Archaeology of Medical Perception*.166

⁵⁶⁹ Gyorgy Kepes, *Language of Vision* (New York: Dover Publications, 1995). quoted in Rowe and Slutzky, “Transparency: Literal and Phenomenal.” 45



Figure 168. Berlin Museum of Medical History at the Charité

Source: Thomas Schnalke and Isabel Atzl, eds. *Dem Leben auf der Spur: im Berliner Medizinhistorischen Museum der Charité* (Prestel, 2010).

4.3.3. X-Ray Visualization

Depending upon the scientific advancements, novel technologies are introduced to the medical science. The emergence of new medical visualization techniques and imaging devices change the ways the human body is perceived, communicated and studied. As the medical representation continuously transforms, so does the architectural representation and there exist visible or invisible links between them.

Towards the end of the 19th century, an interest towards the human body with a specific focus on health and strength has developed. The beginning of the “modern” Olympic Games in 1896 could be the most evident sign of this enthusiasm. The concept of wellness started to be treated as a health issue and the rising importance of fresh water and air and exercise caused a rapid growth in the fitness and selfcare industry. During the time period between the end of 19th and the beginning of 20th century, new spaces such as specialized hospitals, sanatoriums, asylums, artificial beaches, spa centers and fitness halls have emerged in relation with the development of new concerns and interests.⁵⁷⁰ In addition, exhibitions, publications and seminars on different health-related issues proliferated.

⁵⁷⁰ Ferreira, “Embodied Emotions: Observations and Experiments in Architecture and Corporeality.”139



Figure 169. Fresh air therapy is just one of a range of holistic treatments used in early 20th-century mental hospitals.

Source: “What Was Life like in Mental Hospitals in the Early 20th Century,” accessed July 8, 2020, <https://www.aber.ac.uk/cy/dges/news/article/title-227244-cy.html>.



Figure 170. Jean Saldman, revolving sanatorium, Aix-les-Bains, France, 1930

Source: Beatriz Colomina, *X-Ray Architecture* (Altenburg: Lars Müller Publishers, 2019).77



Figure 171. Children exercising on the terrace of the physical education institute of Karla Hladka dancing school

Source: Beatriz Colomina, *X-Ray Architecture* (Altenburg: Lars Müller Publishers, 2019).111



Figure 172. Artificial beach, Aix-les-Bains

Source: Beatriz Colomina, *X-Ray Architecture* (Altenburg: Lars Müller Publishers, 2019).76



Figure 173. A section of the exhibit on respiration, Health Exposition of Berlin, 1935. From: H.E. Kleinschmidt, "New Germany teaches her People. An Account of the Health Exposition of Berlin", *American Journal of Public Health and the Nation's Health*, 1935, 25, p. 1112.

Source: Elena Canadelli, "Scientific Peep Show": The Human Body in Contemporary Science Museums," *Nuncius* 26, no. 1 (2011): 159–84, 171

Wilhelm Conrad Röntgen's 1895 discovery of the X-ray, was greeted with a great enthusiasm as one of the technological marvels of the time.⁵⁷¹ It was first published in the article entitled "On a New Kind of Rays, a Preliminary Communication," where Röntgen wrote about "a new form of transparency in which 'bodies behave to the X-rays as turbid media to light.'"⁵⁷² In terms of opening up the opportunity to see through the skin, into the corporal interior, X-ray saved lives and "profoundly stirred the cultural imagination."⁵⁷³ Röntgen received the first Nobel Prize in physics and the X-ray technology swiftly became essential for medical scholars and practitioners.



Figure 174. The hand of Bertha Roentgen: the first X-ray image, 1895.

Source: Beatriz Colomina, *X-Ray Architecture* (Altenburg: Lars Müller Publishers, 2019).122

⁵⁷¹ Sappol, *Dream Anatomy*. 154

⁵⁷² Wilhelm Röntgen, "On a New Kind of Rays," *Nature*, January 23, 1896, 274–76; English translation of the 1895 original text "Über eine neue art von strahlen," published in the *Sitzungsberichte der Physikalisch-Medizinischen Gesellschaft in Würzburg* 137, December 28, 1895, 132–41. quoted in Colomina, *X-Ray Architecture*.

⁵⁷³ Michael Sappol. *Dream anatomy*. No. 5. National Institutes of Health, 2006. 154

The major statement of Röntgen was that “all bodies possess this same transparency, but in very varying degrees.”⁵⁷⁴ This meant that, human body which seemed like an opaque entity, had a certain level of transparency that could be visualized through X-rays.

In the 20th century, the widespread use of the X-ray made a new way of architectural thinking possible. In her recent publication “X-Ray Architecture”, Beatriz Colomina unfolds the tremendous effect of medical discourse and imaging technologies on the design, representation and perception of 20th century architecture by focusing on the dominant disease of the time, tuberculosis, and its diagnostic tool, the X-ray. In the first chapter of the book, Colomina expresses her main argument as follows:

“Modern buildings even started to look like medical images, with transparent glass walls revealing the inner secrets of the structures. Indeed, the architecture of the early twentieth century cannot be fully understood without grasping its relationship with disease and especially with tuberculosis, a disease for which X-rays were by chance particularly well adapted as a means of diagnosis and monitoring of the treatment.”⁵⁷⁵

As mentioned in Chapter 4.2.3 the widespread and deadly disease of the time, tuberculosis, was aimed to be prevented, even cured through architecture. Architects took the heavy responsibility of protecting and healing the society from tuberculosis. In that sense, modern architecture promised a hygienic built environment, thus a healthy society.

The main principles of modern architecture directly corresponded to the known causes of the disease. In the late 19th century, the causative factors of tuberculosis were thought to be “unfavorable climate, sedentary indoor life, defective ventilation

⁵⁷⁴ Wilhelm Röntgen, “On a New Kind of Rays,” *Nature*, January 23, 1896, 274–76; English translation of the 1895, original text “Über eine neue art von strahlen,” published in the *Sitzungsberichte der Physikalisch-Medizinischen Gesellschaft in Würzburg* 137, December 28, 1895, 132–41. quoted in Colomina, *X-Ray Architecture*. 120

⁵⁷⁵ Colomina. 16

and deficiency of light.” In response, modern architecture offered “sun, light, ventilation, exercise, roof terraces, hygiene, and whiteness” to the people.⁵⁷⁶

“In his book *The Radiant City* of 1935, Le Corbusier dismissed the “natural ground” as a dispenser of rheumatism and tuberculosis” and declared it to be “the enemy of man”. He advocated pilotis to detach buildings from the “wet, humid ground where disease breeds,” and roof gardens for sunbathing and exercise.”⁵⁷⁷

In that sense, it is possible to say that the characteristic features of modern architecture - pilotis, roof garden, glass walls, and clean air – meant more than being mere ideals defining the new architectural taste but served as “medical devices.”⁵⁷⁸ With this understanding, the line separating the medical spaces from others blurred. Houses, schools and offices almost transformed into “sanatoriums” in terms of simulating the functions of a health facility and the architects became like biologists studying the human body or doctors curing the society. (Fig. 175)

The medical posters and the covers of architectural magazines included illustrations that referred to tuberculosis as juxtaposed with the architectural or urban drawings. The June 1952 cover of the *Revista Nacional de Arquitectura*, includes the image of a sanatorium building with a lung X-ray on the background and a vivid sun depiction. (Fig. 176) It could be argued that X-ray image indicates the fresh air and the sun points out the adequate lighting provided by the sanatorium building and underlines the main concerns of modern architects.

⁵⁷⁶ Beatriz Colomina, ““Skinless Architecture,”” 2008, 123–24, <https://core.ac.uk/download/pdf/224742796.pdf>.

⁵⁷⁷ Colomina.

⁵⁷⁸ Colomina, *X-Ray Architecture* .22



Figure 175. Le Corbusier portrayed as a biologist. Pierre Winter. "The Point of View of a Biologist."1993. Colors edited by the author

Source: Beatriz Colomina, *X-Ray Architecture* (Altenburg: Lars Müller Publishers, 2019).30

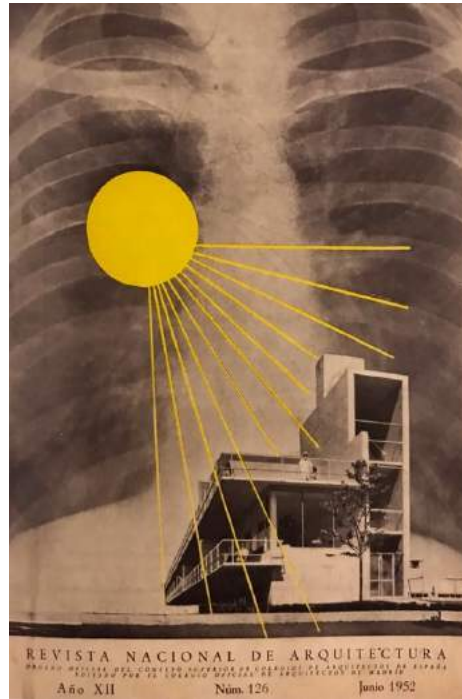

Figure 176. Cover of the Revista Nacional de Arquitectura 126, June 1952, with an image of Lake County Tuberculosis of Sanatorium superimposed on an X-ray of lungs

Source: Colomina, 74



Figure 177. Terrace of the villa Stein at Garches. Film still from L'Architecture d'aujourd'hui, 1929, by Pierre Chenal and Le Corbusier

Source: Colomina, 22



Figure 178. Le Corbusier, Architecture et urbanisme, suspended garden, Immeuble Wanner, Geneva, 1928-1929.

Source: Colomina, 30



Figure 179. Marcel Breuer, apartment for Hilde Levi in Berlin, 1930

Source: Colomina, 28

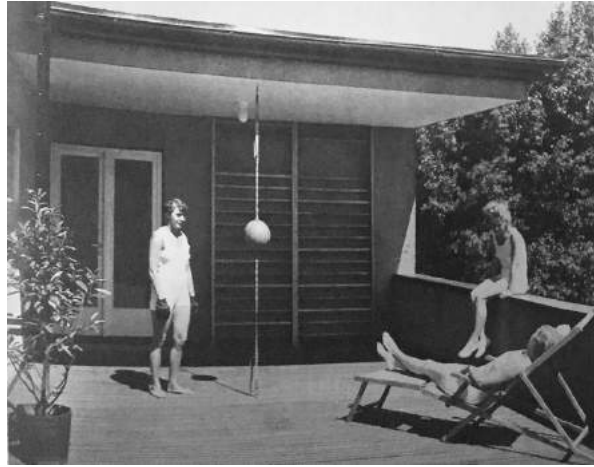

Figure 180. Theo Effenberger, house in the Werkbund housing exhibition, Breslau, 1929

Source: Colomina, 29

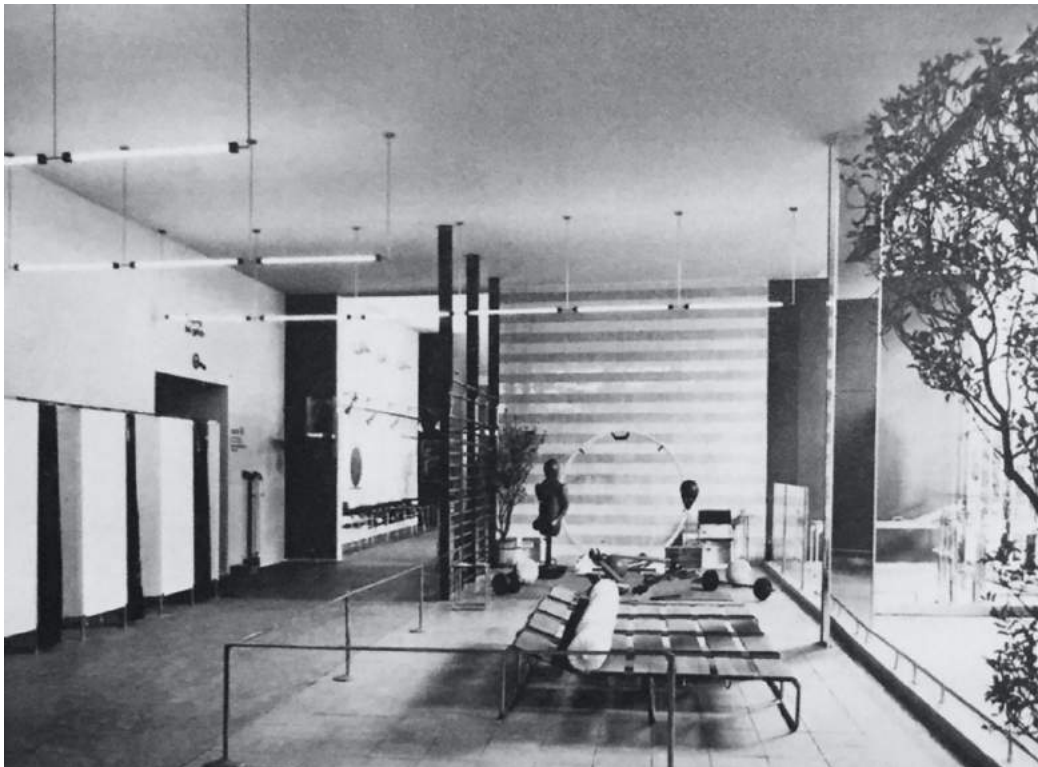

Figure 181. Walter Gropius, communal gym for apartment house, German Building Exhibition, Berlin, 1931

Source: Colomina, 29

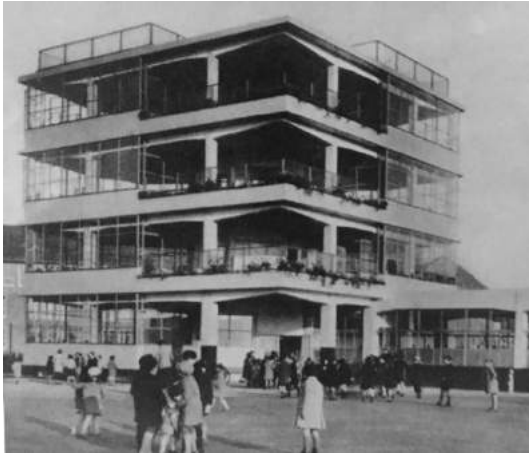

Figure 182. Bernard Bijvoet, Jan Duiker, Open Air School for Healthy Children

Source: Colomina, 98



Figure 183. Postcard of children resting and bathing in the sun in Suresnes open-air school

Source: Colomina, 99

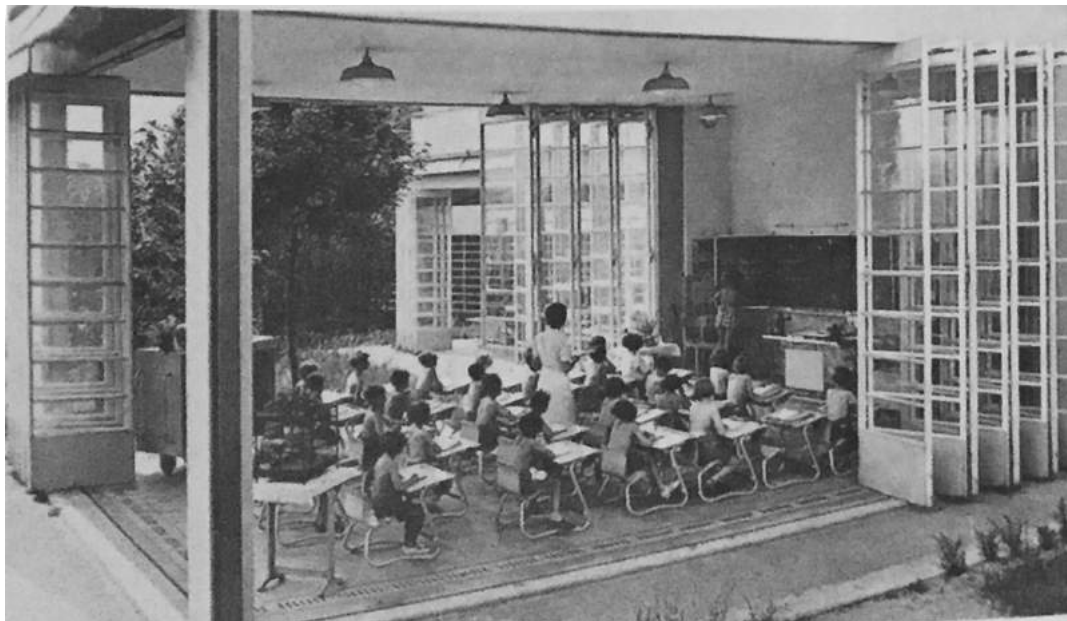

Figure 184. Classroom with retractable walls

Source: Colomina, 99

The development of modern architecture in parallel with the X-ray technology made “transparency” a dominant concept in architectural design and representation. Mies van der Rohe, one of the most influential figures of modern architecture, described his work as “skin and bones” architecture and “rendered his projects for the Friedrichstrasse Skyscraper of 1919 and his Glass Skyscraper of 1922 as if seen through an X-ray machine.”⁵⁷⁹ In fact, Mies’ interest in X-ray images was not implied, he explicitly expressed his enthusiasm by including them in his articles. (Fig.185)

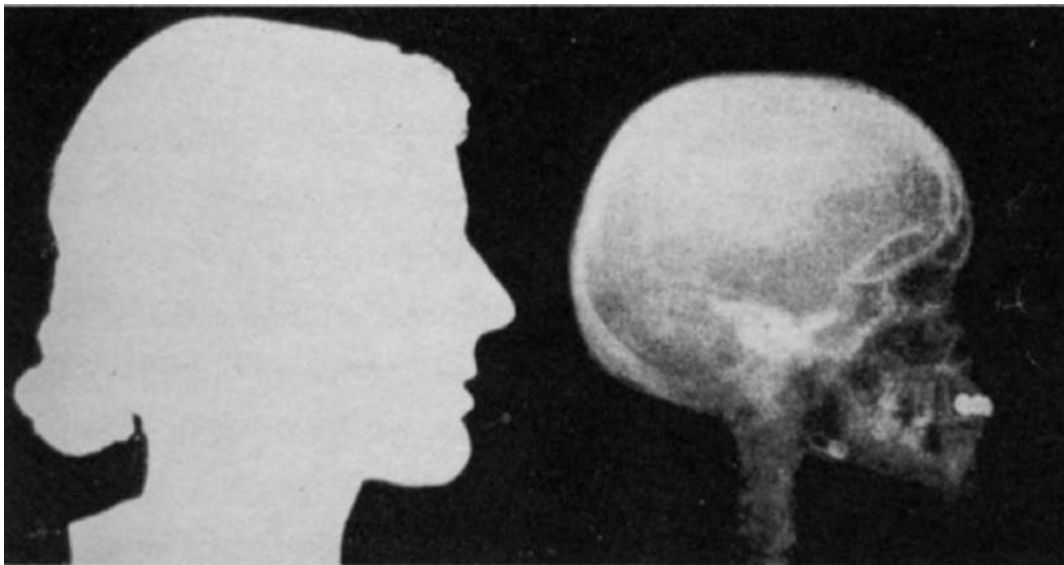

Figure 185. Silhouette and X-ray of the same head, used as illustration in Mies van der Rohe's article in *G:Zeitschrift für elementare Gestaltung*, no. 5-6. April 1926.

Source: Colomina, 138

It is possible to say that, the concept of X-ray vision was not limited to the X-ray image itself. The idea behind it affected other anatomical displays. Transparent Man⁵⁸⁰ sets a good example to this argument. As written by Canadelli:

⁵⁷⁹ Colomina. 137

⁵⁸⁰ In German *Gläserner Mensch*, was the symbol of Deutsches Hygiene-Museum in Dresden from 1930 on. It was a plastic anatomical model with a translucent skin, enabling the visitors to see the corporal interior, bones, veins, muscles and organs, without any obstruction. Explained in Canadelli, “‘Scientific Peep Show’: The Human Body in Contemporary Science Museums.”168

“Through the translucent skin one could see the bones, tissue, veins, nerves, muscles, entrails, respiratory organs.”⁵⁸¹

Just like the Transparent Man revealing the corporal interior including the bones, veins, muscles and organs, the glass envelope exposed the structural elements, floors and walls of the buildings. (Fig. 186-187) While describing the modern architecture Colomina used the phrase “glass skins revealing inner bones and organs” which underlines the powerful analogy established between the architectural artefact and the human body in early 20th century context. With the revealing character of X-ray imaging, the lines between exterior and interior blurred and a new kind of intimacy was introduced.

“While the X-ray exposed the inside of the body to the public eye, the modern building unveiled its interior, subjecting what was previously private to public scrutiny.”⁵⁸²

Especially, the changing perception of intimacy and privacy was most visible in modern house projects such as Mies’s Farnsworth House (1945-1951) in Plano, Illinois, and Philip Johnson’s Glass House (1949) in New Canaan, Connecticut. The glass house exposed its domestic interior space, just as the X-ray exposed the inside of the body to the public eye.

In an interview published in *House Beautiful*, Edith Farnsworth compared her renowned weekend house designed by Mies to an X-ray image by saying that “the house is transparent, like an X-ray.” In addition, Colomina mentioned that there was a rumor about the house that it was a tuberculosis sanatorium, based on its white structure and continuous glass façade.⁵⁸³

⁵⁸¹ Canadelli.168

⁵⁸² Colomina, ““Skinless Architecture.”” 123

⁵⁸³ Colomina, *X-Ray Architecture*. 146

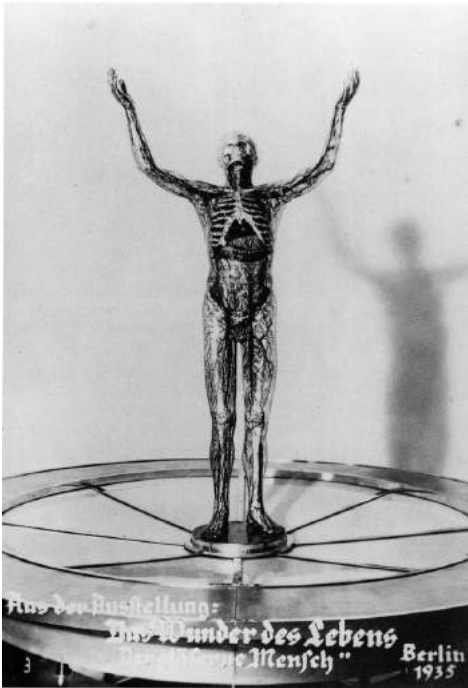

Figure 186. Franz and Fritz Tschakert, Transparent Man, 1927. Mixed media. German Hygiene Museum, Dresden.

Source: Jeffrey T. Schnapp, "Crystalline Bodies: Fragments of a Cultural History of Glass," *West 86th* 20, no. 2 (2013): 173–94, 187

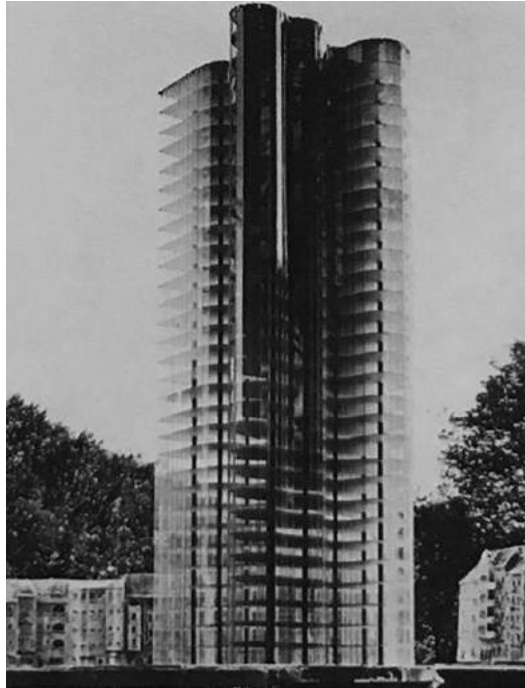

Figure 187. Mies van der Rohe, model of the Glass Skyscraper, Berlin, 1922

Source: Beatriz Colomina, *X-Ray Architecture* (Altenburg: Lars Müller Publishers, 2019), 153



Figure 188. Philip Johnson, Glass House, New Canaan, CT, 1949

Source: Colomina, *X-Ray Architecture*, 142

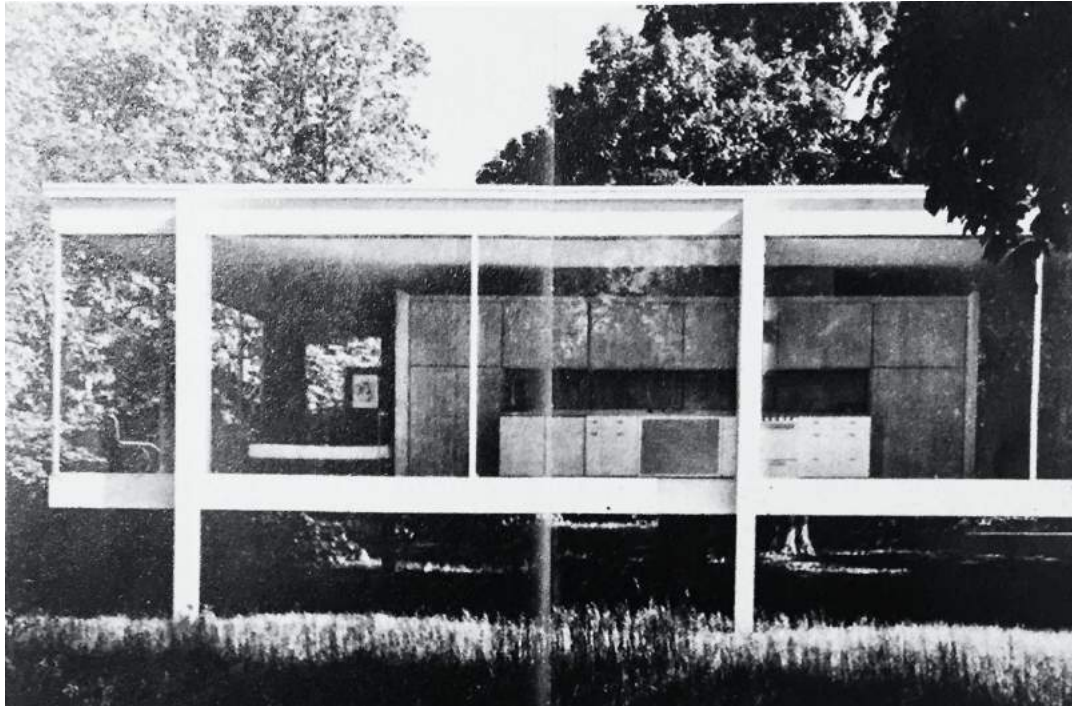

Figure 189. Mies van der Rohe, Farnsworth House, 1949

Source: Colomina, *X-Ray Architecture*, 153

X-ray aesthetics was present in many other buildings of the time. Numerous prominent projects including “Le Corbusier’s project for the Glass Skyscraper (1925), Walter Gropius and Adolf Meyer’s Bauhaus (1925-1926, Brinkman and van der Vlugt’s Van Nelle Factory (1925-1927) in Rotterdam, Erich Mendelsohn’s Schocken Department Store (1926-1928) in Stuttgart, Buckminster Fuller’s 4D Tower (1928), George Keck’s Crystal House (1933-1934) at the World’s Columbian Exhibition in Chicago, Paul Nelson’s Suspended House (1935), Frits Peutz’s Schunck Glass Palace (1935) in Heerlen, Jaromir Krejcar’s Czech Pavilion at the International Exhibition in Paris (1937)”⁵⁸⁴ reflected the impact of X-ray imaging on architecture. As argued by Colomina, this was more than a dominant aesthetic, it was “a symptom of the deep influence of medical discourse on architecture.”⁵⁸⁵

⁵⁸⁴ Colomina. 137

⁵⁸⁵ Colomina. 137

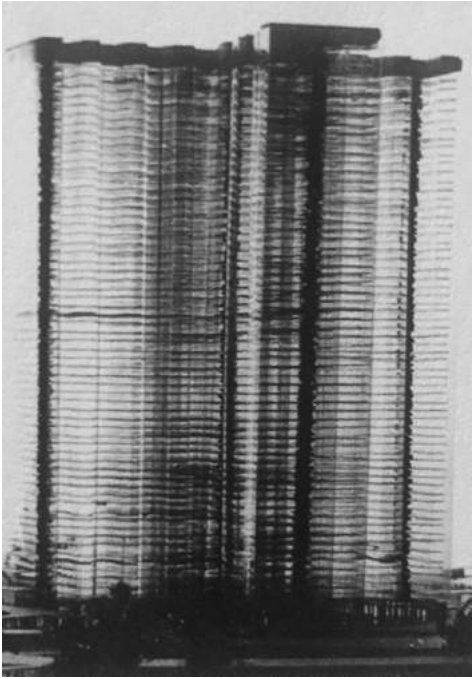

Figure 190. Le Corbusier's project for the Glass Skyscraper, 1925

Source: Colomina, *X-Ray Architecture*, 140

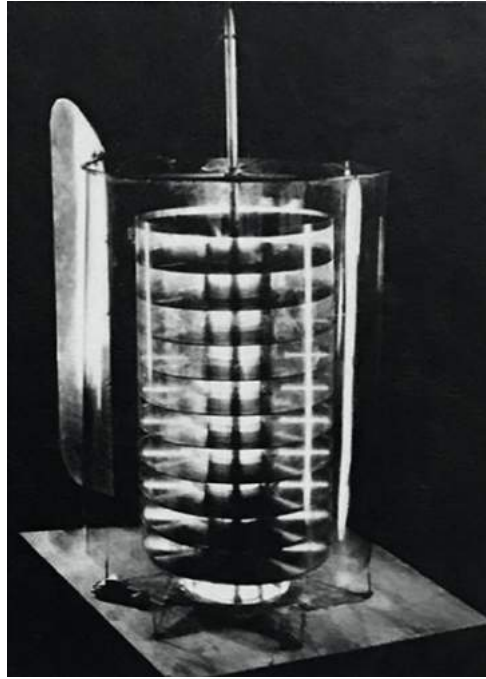

Figure 191. R. Buckminster Fuller, Streamlined Dymaxion Shelter prototype, 1932

Source: Colomina, *X-Ray Architecture*, 141



Figure 192. George Keck, Crystal House, 1933-1934, exhibited at the World's Columbian Exhibition in Chicago, 1934.

Source: Colomina, 141



Figure 193. Frits Peutz, Schunck Glass Palace, Heerlen, the Netherlands, 1935

Source: Colomina, 141

“By this definition, the transparent ceases to be that which is perfectly clear and becomes instead that which is clearly ambiguous. Nor is this meaning an entirely esoteric one; when we read (as we so often do) of ‘transparent overlapping planes,’ we constantly sense that rather more than a simple physical transparency is involved.”⁵⁸⁶

As Colin Rowe and Robert Slutzky wrote in their article, transparency does not refer to a simple optical phenomenon of see-through, it suggests a polysemic condition. Therefore, the concept of transparency introduced by the X-ray technology and its impact on architecture is beyond a superficial analogy, there lies a complex network of meanings, associations and connotations behind it.

In her book, Colomina discusses transparency in a multidimensional setting. Within the context of transparency, she analyses the architecture of the early 21st century and its further reverberations from different seminal perspectives, going beyond the

⁵⁸⁶ Rowe and Slutzky, “Transparency: Literal and Phenomenal.” 45

commonplace discourse on “glass architecture”. According to her, X-ray image and its impact on architecture implies further meanings that cannot be reduced to the revelation of the interior. One of the most notable arguments is about the very nature of the X-ray image that is “not simply an image of the body,...it is an image of the body being imaged.”⁵⁸⁷ Within this context, she describes *X-ray architecture* as follows:

“Glass architecture echoes the logic of the X-ray. There is an outer screen that disappears in order to register a ghostly image of the inside. It is X-ray architecture. As with Rontgen’s transformative images, X-ray architecture is an image of an image—the effect of an X-ray, rather than an actual X-ray. It’s not so much that the inside of the building is exposed, but that the building represents exposure, and this exposure occurs on a screen. Glass is called on to simulate transparency.”⁵⁸⁸

Transparency introduced to the architectural milieu through the X-ray technology is not the pure expression of the inside to the outside, but a complex phenomenon. The glass façade creates an illusion and enacts the idea of an “image of an image.” Apart from displaying the interior space, it acts like a screen. Glass, more than creating transparent effect, represents the transparency itself. This duality is the essence of X-ray imaging and, thus constitutes the essence of glass architecture.

“The exterior envelope is still a kind of shadow or a blur, and you feel yourself looking through it. To look at an X-ray is to feel one’s eye penetrating the surface of the body and moving through space. It is inevitably voyeuristic. Perhaps that’s what attracted architects to the X-rays from the beginning. In glass architecture, the glass is never completely transparent. Even at night, you feel the outer limit of the building and your eye passing through that limit. You feel the exposure. Modern architecture exposed itself, but not by revealing everything. Rather, it staged the act of exposure, calling the eye in.”⁵⁸⁹

⁵⁸⁷ Colomina, *X-Ray Architecture*. 149

⁵⁸⁸ Colomina. 135

⁵⁸⁹ Colomina. 149

As stated by Colomina, glass, more than exposing the interior, exposes the act of looking. Glass architecture is not about seeing, it is about the temptation to see. Beyond the mere act of seeing, the appealing opportunity to see what is normally hidden makes these modern buildings interesting and exciting. Due to reflection, shadow and blur glass facades do not offer full transparency, therefore they create the illusion of transparency. The transparent appearance, despite not providing pure transparency, invites the curious eyes in. The possibility of an instant intimacy is more attractive than the intimacy itself and it is possible to argue that the *X-ray architecture* is based on creating this playful simulacrum.

“Mies famously deployed sheer glass walls to expose the interior. But what really fascinated architects such as Mies and those inspired by him, such as Philip Johnson, was not the way the gaze passes through the glass, but the way it seems to get caught in the layers of reflection.”⁵⁹⁰

Through blur and reflections, the glass loses its transparency and gains an opaque quality. In canonical photograph, Philip Johnson’s Glass House seems almost opaque, clad in as described as “wallpaper” by the architect himself. For Mies and Johnson reflection “consolidate the wall’s plane.”⁵⁹¹ As written by Colomina “[c]omplex lines of reflected trees become like the veins of marble in Mies’s buildings.”⁵⁹² Regarding the significant role played by reflection in glass architecture Mies said:

“I discovered by working with actual glass models that the important thing is the play of reflections and not the effect of light and shadow, as in ordinary buildings.”⁵⁹³

⁵⁹⁰ Colomina. 151

⁵⁹¹ Colomina. 153

⁵⁹² Colomina. 153

⁵⁹³ Colomina. 153



Figure 194. Reflections in the Glass House, Philip Johnson, New Canaan, Connecticut, 1949

Source: Colomina, 152

The glass architecture culture established and developed by Mies and his peers, absorbing and refining the X-ray effect inspired many subsequent works. The architectural approach of SANAA inherits the Miesian tradition of transparency and brings it to the next level. Colomina described the visionary architecture of SANAA as follows:

“SANAA’s vision is far from crystal clear. In fact, their work appears to be more interested in further blurring the view, softening the focus, than in sustaining the supposed transparency of early avant-garde architecture. Within SANAA’s architecture, structure is never revealed. Their buildings are optical devices without any visible mechanisms. The real view is not just from the outside looking even further inward, not to discover the inner secret of the building, but to be suspended in the view itself. The visitors are often literally between walls of glass or acrylic. What they see, through the shiny layer in front of them, is another layer and then another, with the juxtaposed reflections off each surface dissolving any line between inside and outside.

Peering through all the layers, vision softens and distorts, with the curves and ripples of the glass accentuating the distortion.”⁵⁹⁴

Favoring blurry and distorted over clear-cut edges, visible contours and rigid boundaries, the works of SANAA enhanced the concept of transparency in architecture by engaging the sense of vision in an exceptional way. SANAA implicitly contributed to the deep-rooted philosophy of architectural design influenced by medical discourse in terms of sustaining the X-ray aesthetics embodied in the glass architecture of the early 20th century. *X-ray architecture*, having started with the lungs and proceeded with the eyes, has incorporated the human body to the architectural practice and established a unique relationship between the body and architecture.



Figure 195. SANAA, rendering of the Glass Pavilion at the Toledo Museum of Art, Ohio, 2006

Source: Colomina, 152

⁵⁹⁴ Colomina. 157



Figure 196. Novartis Pharma Headquarters, Basel, 2002

Source: Colomina, 156



Figure 197. View of SANA's installation in the Mies van der Rohe Pavilion, Barcelona, 2008

Source: Colomina, 164



Figure 198. View of SANAA's installation in the Mies van der Rohe Pavilion, Barcelona

Source: "SANAA. Intervention in the Pavilion," accessed July 8, 2020, <https://miesbcn.com/project/sanaa-intervention/>.

4.3.4. Layering

In Western anatomical practices, the human body has been consistently imagined, studied and displayed as a "composite of layers." The visualization of the anatomical body in terms of layers took place in manifold materials including paper, plaster, and flesh itself. Revealing layer by layer the complex interiors of the entire body or a certain organ, part or system in specific, has been considered as a clear and accurate way of teaching and communicating the anatomical knowledge.

Anatomical fugitive sheet, which is an innovative assemblage of printed cut-outs and paper flaps, was first produced around 1538 in Germany by the printer and engraver Heinrich Vogtherr the Elder.⁵⁹⁵ (Fig. 199-200) It could be considered as an updated version of standard anatomical print, as it transforms the two dimensional image into a "spatialized and animated"⁵⁹⁶ one. Depiction of the body as a spatial entity had long posed a problem, which was overcome through fugitive sheet technique. Body is peeled away layer by layer and after each layer that is pushed aside, another level

⁵⁹⁵ Moore, "Paper Cuts: The Early Modern Fugitive Print." 54

⁵⁹⁶ Moore. 57

of the hidden interiors of the body is brought into visibility. The sheets stacked up on top of each other, each depicting a distinct stratum of the viscera, imply the three-dimensional quality of the body. Different from the conventional illustrations showing the body as dissected and/or dismembered on a single sheet, anatomical fugitive sheets suggest a spatial experience, a journey towards the inner depths of the body. In that sense, fugitive sheets present a “spatialization of the body’s interior, which is not the same as the representation of the interior of the body”⁵⁹⁷.

When looking through the fugitive sheets, the act of lifting the corporeal layers one by one to make the internal organs visible is conceptually quite similar to the dissection carried out in the anatomical theatre or the dissecting room. The dissection process “envisaged as a movement through ‘strata’- from the surface of the skin and ‘superficial structures’ into the body’s ‘deep structures’ such as the internal organs and bones”⁵⁹⁸ is enacted through the fugitive sheets. Each layer representing certain organs at a certain level of the body, could be considered as the metaphor of “cutting”. In better terms, each sheet is a metaphorical cut through the inner space of the body.

Fugitive sheets mobilize the “cut” to make the interior of the body visible. Unlike other prints, they provide a tactile interaction, “inviting users to engage with and activate the image, rather than passively receiving its prescribed message.” Through the bodily participation, the user finds a chance to enter and traverse the internal space of the body which reveals the anatomical knowledge. Regarding the relationship between fugitive sheets and the production of knowledge Rosemary Moore wrote:

“If fugitive sheets produce knowledge, it is through the act of cutting, marking and inscribing on the body. These cuts are both literal and imagined by the users of fugitive sheets, and can be conceived of in two ways. Firstly the sheets are, at least partly, concerned with medical knowledge – the production of which involves the anatomist cutting into, fragmenting then dividing the body in order to reveal its internal secrets. The scalpel pierces

⁵⁹⁷ Moore. 59

⁵⁹⁸ Hallam, *Anatomy Museum: Death and the Body Displayed*. 298

the skin's boundary in order to open up the body and the knowledge to be acquired from looking inside it, to the viewer's inquisitive gaze. The cut, however, conjoins as well as divides the body – it brings together different kinds of knowledge, making them visible on the body's surfaces. Secondly, the notion of cutting into or incising is also activated through the technology of print itself. Visual information is formed and constructed by repeatedly cutting lines, marks and forms into the woodblock. Metaphors of cutting into the body and inscribing knowledge through technologies of printing thereby converge in the sheets and this is further heightened by the viewer's physical interaction with the cut; in effect the user of the print repeats the cut as they lift the moveable paper flaps. What is brought into visibility and what remains outside of visibility are entirely dependent on multiple concepts and negotiations of the cut."⁵⁹⁹

⁵⁹⁹ Moore, "Paper Cuts: The Early Modern Fugitive Print." 57

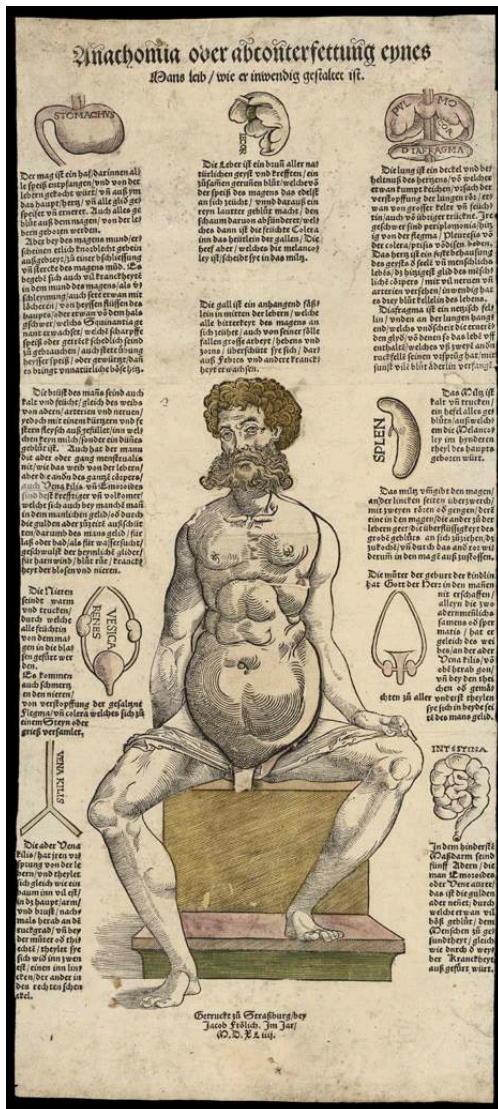

Figure 199. Jacob Frölich (after Heinrich Vogtherr), *Anatomy, or, a faithful reproduction of the body of a male (Anathomia oder abconterfetzung eines Mans leib)*, 1544

Source: Rosemary Moore, "Paper Cuts: The Early Modern Fugitive Print," *Object* 17, no. 1 (2015): 54–76, 56

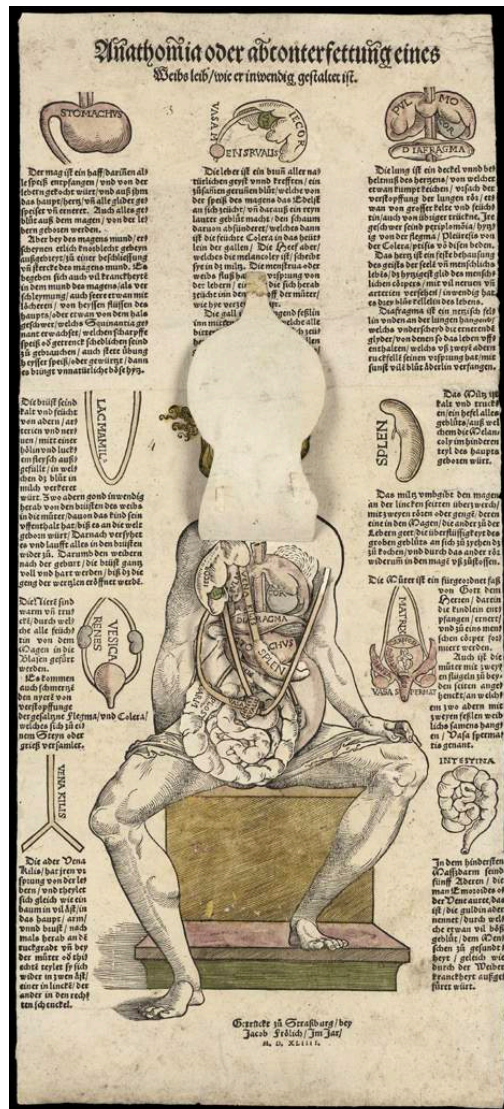

Figure 200. Jacob Frölich (after Heinrich Vogtherr), *Anatomy, or, a faithful reproduction of the body of a female (Anathomia oder abconterfetzung eines Weibs leib)*, 1564

Source: Moore, "Paper Cuts: The Early Modern Fugitive Print," 55

The technique introduced by Heinrich Vogtherr is further developed and used after the 16th century in anatomical teaching. Anatomical flap books called "movable atlases" designed by the physician Gustave Joseph Witkowski and published in 1880s have been vastly used as a teaching material. These atlases represented the

body parts as colored paper layers fastened together in sequences enabling the user to move from one to the next and back again. The way Witkowski imagined and expressed the body parts draws attention. For instance, the movable atlas depicting the eye in large-scale was named as “the mechanism of vision” and the one representing the ear was named as “the mechanism of hearing”. The selection of the word “mechanism” underlines the fact that the body was thought as a machine⁶⁰⁰ and the flap anatomical atlas including hinged layers that could be lifted up and down enhanced this idea.⁶⁰¹ (Fig.201) Regarding its degree of detail and comprehensive content, Witkowski’s atlas aimed at an audience of medical students and researchers. Nevertheless, simpler, and less-specialized versions of these anatomical flap books have been designed such as Philip’s Popular Mannikin published in c.1990 depicting the human body in five main layers: the skin, muscles, blood vessels, nervous system and skeleton. (Fig.202)

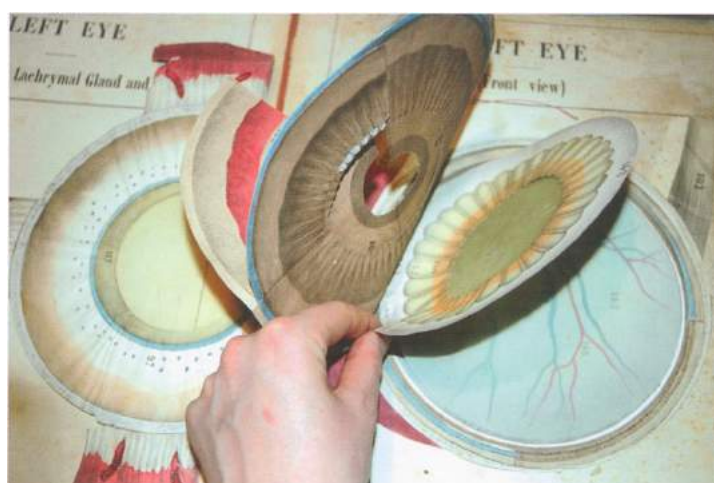

Figure 201. Anatomy of the eye shown in layers of paper, from Gustave Joseph Witkowski, *Human Anatomy and Physiology. Part IV. A Movable Atlas Showing the Mechanism of Vision; The Eye; The Organs of Vision* (London, 1880-89)

Source: Elizabeth Hallam, *Anatomy Museum: Death and the Body Displayed* (London: Reaktion Books, 2016), 299



Figure 202. Anatomy of the skeleton and organs shown in layers of paper, from William S. Furneaux, ed., *Philip’s Popular Manikin* (London, c. 1900)

Source: Hallam, 300

⁶⁰⁰ The concept of “body as a machine” is further elaborated in Chapter 5.1.2.

⁶⁰¹ Hallam, *Anatomy Museum: Death and the Body Displayed*. 299

Bailliere's Synthetic Anatomy, created in 1920s by Dr. John Eric Cheesman, had a distinctive feature. Different from previous examples of anatomical flap atlases, its consecutive sheets of colored drawings were printed on a transparent medium. Through the opportunities offered by the transparent medium, students could "see inside the body from many 'points of view' at once" and improve "the ways in which three-dimensional anatomical structures and their relations were mentally 'visualised'."⁶⁰² Another remarkable quality of the atlas was the coordinate system developed for locating the body parts with respect to each other and within the overall anatomical layout. Like a map, the coordinates of each component were given in an accompanying index. In addition, at each page vertical and horizontal scales were provided to aid students for the positioning of the anatomical parts. Through this system, the anatomical structure of the human body depicted in parts was reconstructed in the minds of medical students. It is possible to say that the idea of mentally mapping the body in three-dimensions, explained in Chapter 2.2.1, is embodied through Cheesman's atlas. As Hallam wrote:

"This reconstruction was akin to reassembling an anatomical model, and it was devised to help the student build a 'composite and stereoscopic mental picture' of each part being studied."⁶⁰³

The atlas composed of fourteen sections, each devoted to an anatomical region. Within each section, twelve printed pages represented six slices through the anatomical part in question. The sections were connected to each other with removable wire stitches which allowed students to subtract or add pages and create alternative sequences and groupings. The students could also insert blank pages underneath the transparent sheets to see them more clearly or repeatedly reproduce the anatomical layers with tracing paper.⁶⁰⁴ All these possibilities enabled students

⁶⁰² J. E. Cheesman, *Bailliere's Synthetic Anatomy: A Series of Drawings on Transparent Sheets for Facilitating the Reconstruction of Mental Pictures of the Human Body*, Part 2. The Forearm (London, 1926-36) quoted in Hallam. 301

⁶⁰³ Hallam. 301

⁶⁰⁴ Hallam. 302

to personalize the atlas and interact with it in different ways which significantly enhanced the learning process. (Fig. 203)

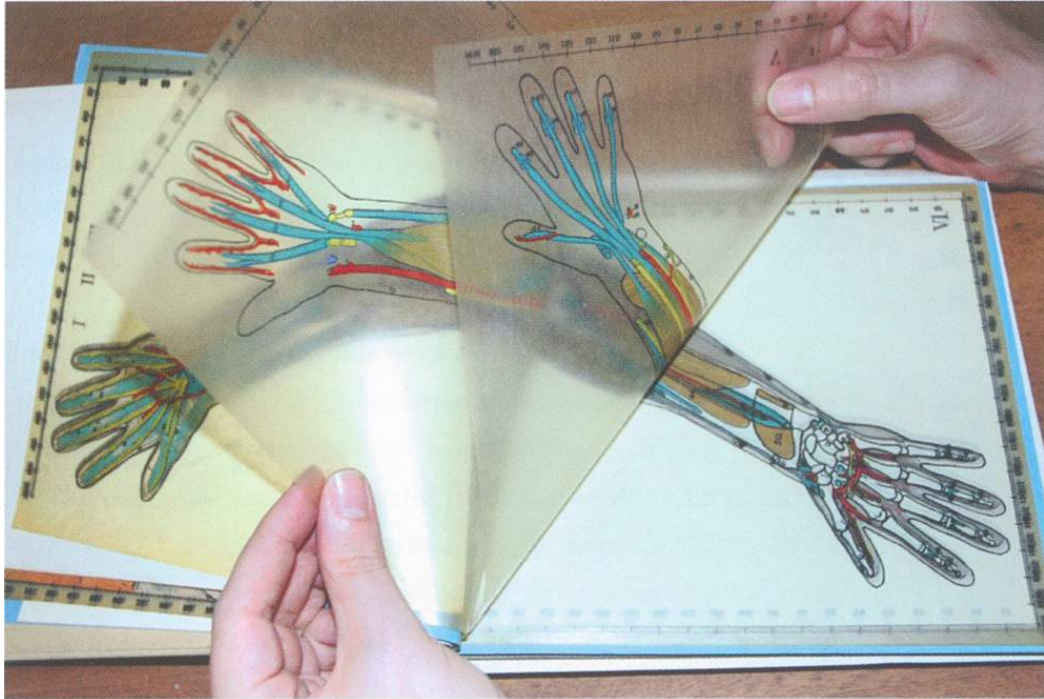

Figure 203. Anatomy of the forearm in layers, from J. E. Cheesman, Bailliere's Synthetic Anatomy: A Series of Drawings on Transparent Sheets for Facilitating the Reconstruction of Mental Pictures of the Human Body, Part 2. The Forearm (London, 1926-36)

Source: Hallam, 301

Layering is also a highly mentioned and implemented notion in architectural theory and practice. The method of layering has been employed as a design concept by many prominent architects. The concepts of layering and stratification are quite observable in Le Corbusier's works. Both his paintings and architectural designs comprised complex layering compositions. Colin Rowe and Robert Slutzky mention the concept of "spatial stratification"⁶⁰⁵ regarding Le Corbusier's villa at Garches. The layers designed by Le Corbusier expand in axonometric view and flatten when looked at perpendicular to the planes defined by the layers.

⁶⁰⁵ For more detailed analysis regarding the layering concept employed by Le Corbusier see Robert Slutzky Colin Rowe, "Transparency: Literal and Phenomenal," *Journal of Architecture and Building Science* 129, no. 1660 (2014)

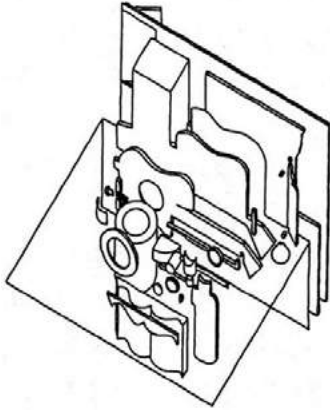

Figure 204. Axonometric of Le Corbusier's Still Life, 1920

Source: "Transparency II: Layering of Planes/Layering of Spaces," accessed July 8, 2020, <https://architecturality.wordpress.com/2011/02/24/transparency-ii-layering-of-planeslayering-of-spaces/#comments>.



Figure 205. Le Corbusier, *Still Life*, 1920

Source: "Le Corbusier (Charles-Édouard Jeanneret)," MoMA, accessed July 8, 2020, <https://www.moma.org/collection/works/79312>.

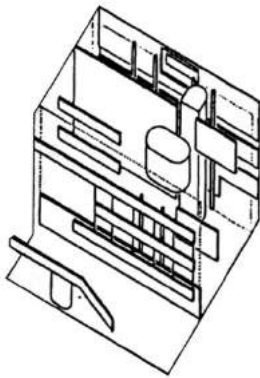

Figure 206. Axonometric of Le Corbusier's Villa Stein at Garches 1927-8

Source: "Transparency II: Layering of Planes/Layering of Spaces"



Figure 207. Photograph of Le Corbusier's Villa Stein at Garches 1927-8

Source: Colin Rowe and Robert Slutzky, "Transparency: Literal and Phenomenal...Part II," *Perspecta* 13/14 (1971): 287-301, <http://www.jstor.org/stable/1566988> .

Adolf Loos is known with his use of “layered space.” Loos was interested in the spatial quality of architecture and considered space as a material in itself. His architectural approach focused on creating spatial continuity between rooms, therefore he did not define his architecture through plans, sections or elevations. In his own words:

“My architecture is in no sense conceived in plans, but instead in spaces (cubes). I do not design any floor plans, facades, cross-sections. I design spaces. For me, there is no ground floor, upper floor etc... For me, it is only about contiguous, continual spaces, rooms, vestibules, terraces etc. Floors mix with each other and spaces meet up with each other.”⁶⁰⁶

The layers in Loos’ architecture were not physical rather perceptual. In his buildings there are invisible, yet perceivable layered planes and spaces. In that sense, his architecture could be considered as “phenomenally transparent.”⁶⁰⁷ Loos’ notion of *Raumplan* refers to the merging of different levels and spaces to create a spatial continuum.⁶⁰⁸ His architecture in terms of enabling the “journey of the gaze”⁶⁰⁹, achieves a spatial fluidity.

⁶⁰⁶ Alena Havlíková, “Adolf Loos,” accessed July 8, 2020, <https://adolfloos.cz/en/adolf-loos>.

⁶⁰⁷ Referred to the two types of transparency: literal and phenomenal in (Rowe and Slutzky, “Transparency: Literal and Phenomenal.”)

⁶⁰⁸ Alan Colquhoun, *Modern Architecture* (New York: Oxford University Press, 2002).

⁶⁰⁹ Beatriz Colomina, “The Split Wall: Domestic Voyeurism,” in *Sexuality and Space* (New York: Princeton Architectural Press, 1992), 73–128.79

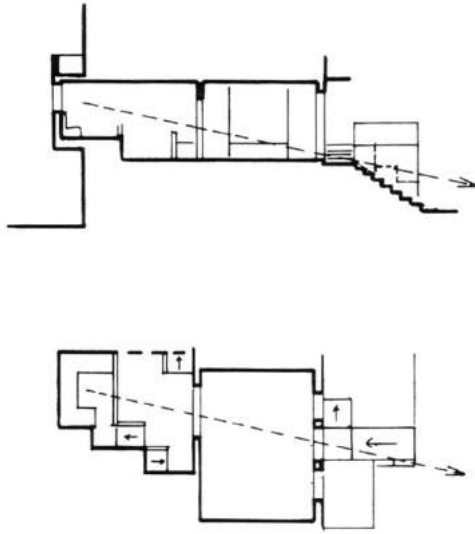

Figure 208. Plan and Section drawings of Moller house in Vienna designed by Adolf Loss

Source: Beatriz Colomina, “The Split Wall: Domestic Voyeurism,” in *Sexuality and Space* (New York: Princeton Architectural Press, 1992), 73–128, 79

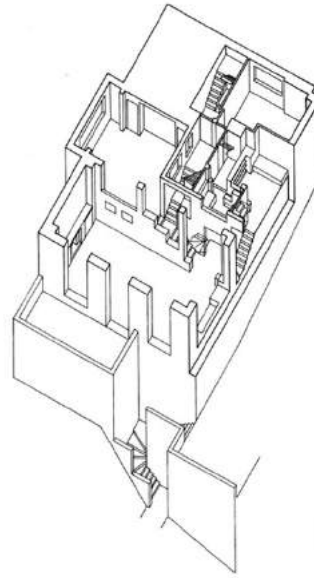

Figure 209. Villa Müller in Prague designed by Adolf Loos’

Source: Transparency II: Layering of Planes/Layering of Spaces”

In his analysis of Casa del Fascio designed by Giuseppe Terragni, Eisenman, considering the southwest facades as the frontal plane, describes the house as a series of successive layers.⁶¹⁰ In his article on Cardboard Architecture: House II, Eisenman wrote:

“the implied planes formed by the columns and beams cut through the volumes in such a way as to create a condition in space where the actual space can be read as layered.”⁶¹¹

⁶¹⁰ Peter Eisenman, G. Terragni, et al, *Giuseppe Terragni: transformations, decompositions, critiques* (New York: Monacelli Press, 2003), 96.

⁶¹¹ P. Eisenman, House II 1969 – Cardboard Architecture: House II, Five architects: Eisenman, Graves, Gwathmey, Hejduk, Meier (New York: Oxford University Press, 1975)

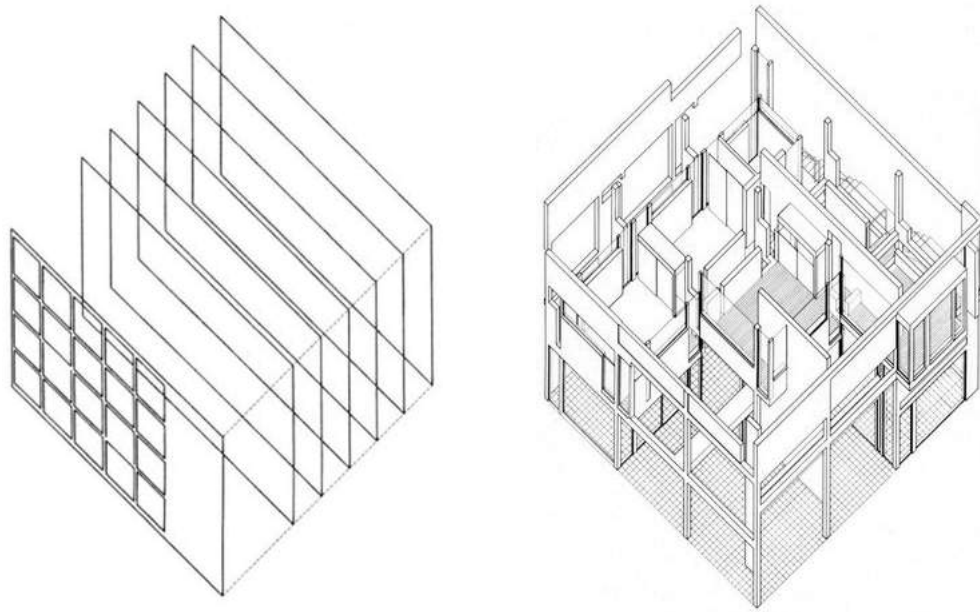

Figure 210. Axonometric analysis diagram of Terragni's Casa del Fascio

Source: "Transparency I: Layering of Planes/Layering of Spaces," accessed July 8, 2020, <https://architecturality.wordpress.com/2010/10/20/transparency-i-layering-of-planeslayering-of-spaces/>.

4.4. (Dis)section

4.4.1. The Cut: Anatomization of the Body

When the etymological background of the word "anatomy" is analyzed, the first part of the word, ana-, means "up", the second part, -tomy, means "cutting" in Greek, so the word literally refers to the dissection or "cutting up" of an organism⁶¹². As the term itself suggests, anatomy is defined by the act of "cutting." In addition, the verb form of anatomy, "to anatomize" has two meanings: to cut in pieces in order to display or examine the structure and use of the parts, to dissect and to examine and

⁶¹² Simon Chaplin, "Anatomy or Ottamy? Bodies on Show in Georgian London," in *The Morbid Anatomy Anthology*, ed. Joanna Ebenstein and Colin Dickey (New York: Morbid Anatomy Press, 2014), 253

analyze in detail.⁶¹³ In this context, it is possible to say that knowing the body begins by dissecting it to overcome the seamless and continuous layer of skin masking the complex organization of the body made up of cells, tissues, organs and systems.

“Let us recall the uncanniness, even disgust, we experience when we endeavor to imagine what goes on just under the surface of a beautiful naked body – muscles, organs, veins... In short, relating to the body implies suspending what goes on beneath the surface. This suspension is an effect of the symbolic order, even when we are undressed, we are not really naked, since skin itself functions as the ‘dress of the flesh’”⁶¹⁴

In fact, normally “cutting (up) something” has a negative connotation. It is considered to be a violent action and associated with unfavorable concepts such as destruction, harm, injury and pain. Nevertheless, in the case of anatomical dissection, the act of cutting the human body is a glorified practice as it is the ultimate way to access the knowledge of the body. Dissection is a bold and fearless move to attain anatomical knowledge, therefore it represents the scientific curiosity and enthusiasm to discover, learn and understand. Regarding the relationship between dissection and knowledge, Lepecki wrote:

“In Europe since the Renaissance, the dissection of dead bodies became a cultural practice which was led by a new drive for knowledge. Here, the issue at stake was primarily visibility and directness. The truth lay hidden under the skin, and it could be tracked down by cutting open and dismembering. At the centre of these actions was the sense of sight. The concern was to open up that which had been previously hidden and to make it immediately evident and visible to all.”⁶¹⁵

Whilst the primary ability of the medical gaze is “plunging into depth and traversing it,” as discussed in Chapter 2.2.1, dissection becomes the embodiment of this ability. This means that it is not just an incision by the scalpel, it is also an incision by the

⁶¹³ “Anatomize,” in *Merriam-Webster Dictionary*, accessed July 8, 2020, <https://www.merriam-webster.com/dictionary/anatomize>.

⁶¹⁴ Slavoj Žižek, *The Metastases of Enjoyment: Six Essays on Women and Causality* (London: Verso, 2005). 116

⁶¹⁵ Aleida Assmann, “Body, Text, Transcendence,” in *ReMembering the Body*, ed. Hortensia Völckers and Gabriele Brandstetter (Ostfildern-Ruit: Hatje Cantz Publishers, 2000), 78–100.80

eye. It is an ocular penetration to the depths of the body. In this framework Elkins wrote:

“Dissection is an especially powerful tool: literally, it is a medical specialty, with its own terms and techniques distinct from surgery; and figuratively, it can stand for any act of systematic analysis, from a tentative “probe” to the “sharpest” critique...Dissection is therefore one of the most apt metaphors for the experience of intense, directed thinking or seeing: the Latin *perspicere*, from which we have the words “perspicuous” and “perspective,” means seeing through, as in piercing a fog or penetrating a dark night. Analytic thought often borrows those visual metaphors, but ultimately perspective, piercing, and penetrating may all depend on the fundamental desire (or fear) of seeing through the skin.”⁶¹⁶

Dissection is an intense operation due to the tension between the inside and outside of the body. The extreme contrast between the smooth and perfect skin and the intricate and repulsive -as many people might describe- viscera, dramatizes the dissection. Therefore, the anatomist’s incision into the flesh, by piercing the intact surface of the body to reach the corporal depths, causes a sudden “aesthetic collapse.”⁶¹⁷ Seeing the interior of the body is a paradox. It is highly tempting and extremely unpleasant at the same time. Elkins describes the mixed feelings towards the viscera as follows:

“...to really see the inside of the body is to risk falling in love with the heady proximity of death, with the incomprehensible tangle of unnamable vessels and chunks of fat, and with the seductive textures of the smooth, sensitive membranes—more delicate than ordinary skin, more sensitive and vulnerable, and above all more redolent of the most intense pain.”⁶¹⁸

The dissection process reveals the complex inner structure of the body following a strict ritual that had been shaped through the centuries with the writings of prominent physicians. The fundamental principle shaping the dissection procedure could be

⁶¹⁶ Elkins, “Cut Flesh.” 119

⁶¹⁷ Moeschl, “Images of the Body: On Sensory Perception in Medicine and in Everyday Life.” 292

⁶¹⁸ Elkins, “Cut Flesh.”

defined as “moving from the surface to deep within the body.”⁶¹⁹ Dissection is the precision work of making the hidden viscera of the body visible. By nature, the flesh is “dense and compact, stuck together and impenetrable.”⁶²⁰ Therefore, the first action, that is the insertion of a sharp object into the intact body to penetrate it, becomes a powerful statement leading the following steps. Hallam describes the dissection procedure as written in contemporary anatomy textbooks as:

“the ‘essence of a good dissection is to display each structure fully, clearly and cleanly’, allowing a ‘mental picture’ to be obtained of that structure, such as a muscle or a blood vessel, by cleaning and defining it rather than just recognizing its existence. Skin was either detached or folded into a ‘flap’ to recover or ‘wrap’ the dissection when not being worked on, thereby helping maintain its moistness. Thus the skin, which is regarded as expressive of the person, was separated from the body so that the anatomical interior could emerge. Fat was cleaned away and tissues teased apart so that students could see and feel distinct muscles, tendons, organs, nerves, blood vessels and bones.”⁶²¹

When the dissection process is unfolded, it is seen that the overall practice is based on the uncovering of the discrete layers of the body including the tissues, organs and systems in a progressive manner. After the first incision by the scalpel, the interior structure of the body is revealed strata by strata. Within this context, anatomical dissection becomes something more than merely “cutting” but also a process of “disassembling.” During the dissection session, the body is divided into pieces and this systematic dismembering results in “an entirely new body – a body of knowledge.”⁶²²

Human cadaveric dissection was “the first means by which the human body was investigated and displayed”⁶²³ and it has been “the primary way of teaching gross

⁶¹⁹ Hallam, *Anatomy Museum: Death and the Body Displayed*.71

⁶²⁰ Koppers, “Visions of Anatomy: Exhibitions and Dense Bodies.”130

⁶²¹ Hallam, *Anatomy Museum: Death and the Body Displayed*.71

⁶²² Gabriele Brandstetter, *ReMembering the Body*, ed. Hortensia Völckers and Gabriele Brandstetter (Ostfildern-Ruit: Hatje Cantz Publishers, 2000). 29

⁶²³ Francesca Monza and Silvia Iorio, “Bodies for Science. The Display of Human Statues for Educational Purposes,” *Medicina Historica* 2, no. 3 (2018): 145–51.146

anatomy to medical students for centuries.”⁶²⁴ This fundamental practice of anatomical scholarship, has indeed, a deep-rooted and multi-geographic history.⁶²⁵

Anatomical dissection had its heyday during the Renaissance, and then slowly lost its effectiveness and disappeared.⁶²⁶ From the 16th century till the final years of the practice, human cadaveric dissections were accommodated by the anatomical theatres built all around the Europe and Great Britain. Anatomical theatre was not simply a space allocated to the anatomical dissections to take place, on the contrary, it was a solid reminder of the things represented by dissection, highlighting that dissection was something beyond just cutting up a deceased body. Ekman explained the divine status of the anatomical theatre as follows:

“The anatomical theatre is not just treated as a premise for the dissection of the human body, but as a device for seeing, unveiling and learning of the microcosm of the human and animal body...”⁶²⁷

⁶²⁴ Papa et al., “The Teaching of Anatomy Throughout the Centuries: From Herophilus to Plastination and Beyond.”

⁶²⁵ The systematic human cadaveric dissection was first introduced in Alexandria around 300 B.C. by the Greek physician Herophilus (335-255), known as the father of anatomy, together with his contemporary, Erasistratus (310-250 B.C.), greatest physiologist of the era. In addition to cadaveric dissection, it was also rumored that they procured criminals from the prison by royal permission and dissected them alive. This bright period ended after 30-40 years, due to the prohibition of the scientific human dissection. Human dissection, after being forbidden for centuries, was authorized again for the first time, along with the progress in medicine, especially anatomy, by the emperor of the Holy Roman Empire, Frederick II. In 1231 he decreed that “medical schools were allowed to dissect at least one human body each five years.” Following this decision in 1315, Mondino de Luzzi (cca. 1270-1326), the Italian physician, anatomist, and professor of surgery at the University of Bologna, carried out the first public human dissection after Herophilus and Erasistratus. Although some critics claim that he only observed the dissections rather than performing them and simply repeated his predecessors’ findings, Luzzi is known as the “restorer of anatomy.” Also, he wrote the first manual of anatomical dissection, with the title *Anathomia*, around 1316. The dissections conducted by the renowned Flemish physician Andreas Vesalius in the early 16th century are considered to be quite significant regarding the anatomical scholarship. The writings of Vesalius favoring the human cadaveric dissection replaced the antiquated theories of the physician, surgeon and philosopher Galen (130-201) from the Roman Empire and became highly influential in the medical milieu. (From Schumacher, “Theatrum Anatomicum in History and Today.” and Alexandra Mavrodi and George Paraskevas, “Mondino de Luzzi: A Luminous Figure in the Darkness of the Middle Ages,” *Croatian Medical Journal* 55, no. 1 (2014).)

⁶²⁶ Schumacher, “Theatrum Anatomicum in History and Today.”16

⁶²⁷ Ekman, “Spatial Orders of Memory and Knowledge: Architectural Schemes for Collections in Seventeenth-Century Sweden.” 150

Due to manifold reasons including the shortage of cadavers available, increasing staff and equipment costs and issues concerning ethical convictions and legal restrictions, the effectiveness of dissection in anatomical teaching declined in time. The gap emerged in the anatomy education caused by the attenuation of the prevalence of dissection practice began to be filled by alternative methods. The role of dissection in anatomical teaching completely transformed after the late 19th century with the invention of X-ray imaging, sonograms, CT scans and MRIs. The possibility of visualizing the interiors of the body without cutting it brought a whole new perspective to the anatomical teaching. Traditional anatomy education was based on topographical structural anatomy taught in lectures and dissection sessions has been replaced with a wide range of study modules including problem-based learning and computer-assisted training. As a result of the present era of “E-learning”, digital tools have come into prominence. Technological tools such as 3D-printing, computer animations and virtual dissection began to take over the medical curriculum. Especially the concept of virtual dissection suggests importance as it digitally imitates the anatomical dissection that took place in the anatomical theatres. For instance, “Anatmage Table,” which is a virtual dissection table, provides a digital body having the colors and forms of the real human body that could be virtually cut and sliced.(Fig.211) All these novel technologies have the potential to enhance the anatomy learning and carry the understanding of the human body to a whole new level. Nevertheless, cadaveric dissection is still considered to be significant in the teaching, research and training of anatomy, as it aids the acquiring of a correct and comprehensive knowledge of human body and ensures the safe and efficient clinical practice. Therefore, in current situation, many medical schools around the world have dissection labs, lectures that involve dissection sessions and body donation programs despite the complex ethical, legal and religious issues.⁶²⁸

⁶²⁸ Papa et al., “The Teaching of Anatomy Throughout the Centuries: From Herophilus to Plastination and Beyond.”



Figure 211. Anatomage Table

Source: “Community Partnership,” accessed July 8, 2020, <https://www.communitypartnershipt.org/news>.

4.4.2. Representing the Dissection

“Historically, modes of anatomical representation, display and performance were linked: illustrators observed dissectors making dissections and tried to make their illustrations look like dissections. Dissectors tried to make their dissections look like the illustrations they had seen in books.”⁶²⁹

Dissecting involves both the cadaveric dissection itself and the illustration of the dissected body. In other words, dissecting denotes both the performance of cutting and the representation of it. “Dissecting as a performative display” is elaborated in Chapter 3.3. Thus, in this subchapter, the focus will be on “dissecting as a representation method”. It is possible to consider an anatomical illustration depicting a dissected body with its viscera revealed, as a “section drawing.”

A section is a frozen moment of dissection. It is a snapshot of the complex process of cadaveric dissection. Although an illustration showing a dissected body is a static

⁶²⁹ Åhrén and Sappol, “The Strange Space of the Body: Two Dialogues.”⁹²

image, it evokes the act of cutting, therefore it has a performative dimension. As Alkan described, “[s]ection displays an ambiguous character that it is the ‘picture plane’ and the act of ‘cutting’ at once.”⁶³⁰

An image representing the dissected body is a powerful statement as it exposes the intricate details of the viscera thus, the complex knowledge of human anatomy. The corporal section in terms of disclosing the secrets of the body, reveals the “truth”⁶³¹ about it. The illustrations of Pietro Berretini da Cortona (1618-1620) produced in the 18th century clearly manifests this condition. (Fig. 212) Cortona’s images show the body cracked open, obscenely displaying its hidden interior space. The ribs, muscles, intestines, kidneys, which are normally perfectly disguised underneath the skin, are all made visible through the illustration. In addition, the tension between the interior and the exterior of the body is masterfully displayed.

Many prominent anatomists, including Andreas Vesalius, Juan Valverde de Hamusco, Pietro Berretini da Cortona, Adriaan van de Spiegel, Amé Bourdon and Francis Sibson incorporated the illustrations of dissected bodies, created by renowned artists, into their treatises.(Fig.213-214-215-216) The images produced by different artists reveal the variety of the strategies employed in the representation of dissected bodies. Each illustration presents a particular construction of the boundary between the interior and exterior realms of the human body, therefore indicates a “different zone of intersection between medical discourse, dissecting practices, representation technologies, aesthetic conventions, and strategies of knowledge production and knowledge transmission.”⁶³² It is important to mention that the method of dissecting has not been limited to the cadaveric dissection taking place in the anatomical theatre or the dissection room, or the representation of the dissected body in two dimensional print media. There have been also wax, wooden or plastic

⁶³⁰ Alper Semih Alkan, “Framing the ‘Invisible’: Section as a Spatial Frame for a Reconsideration of Architectural Representation” (Master’s Thesis, METU, 2004).iv

⁶³¹ Referred to the relationship established between the cross-section and the truth in Åhrén and Sappol, “The Strange Space of the Body: Two Dialogues.”

⁶³² Anja Klöck, “Of Dissection and Technologies of Culture in Actor Training Programs – an Example from 1960s West Germany,” in *Anatomy Live: Performance and the Operating Theatre*, ed. Maaïke Bleeker (Amsterdam University Press, 2008), 113–27. 115

models made with this method, enacting the dissected body in three-dimensional medium of model making. (Fig. 217)



Figure 212. Pietro da Cortona, *Tabulae Anatomicae* 1741. Plate IX.

Source: Ian Maxwell, "Who Were You? : The Visible and the Visceral," in *Anatomy Live: Performance and the Operating Theatre*, ed. Maaikes Bleeker (Amsterdam University Press, 2008), 49–66, 57



Figure 213. Copperplate engraving by Daniel Le Bossu in *Nouvelles tables anatomiques*, Amé Bourdon.1678

Source: Michael Sappol, *Dream Anatomy*, 17



Figure 214. Adriaan van de Spiegel, *De formato foetu liber singularis*, 1626

Source: Anja Klöck, "Of Dissection and Technologies of Culture in Actor Training Programs – an Example from 1960s West Germany," in *Anatomy Live: Performance and the Operating Theatre*, ed. Maaïke Bleeker (Amsterdam University Press, 2008), 113–27. 115

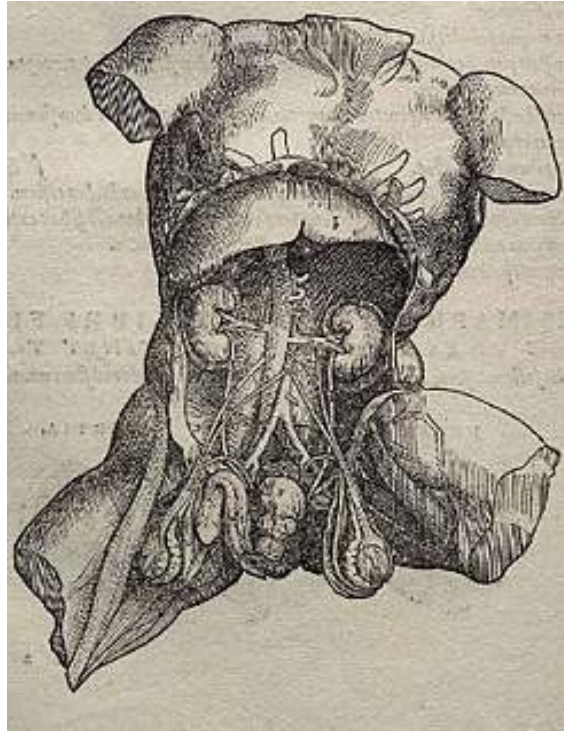

Figure 215. Woodcut engraving by Stephen van Calcar in *De humani corporis fabrica*, Andreas Vesalius, 1543

Source: Michael Sappol, *Dream Anatomy* (Bethesda MD and Washington DC: US Dept. of Health and Human Services, National Institutes of Health, National Library of Medicine, 2006), 11

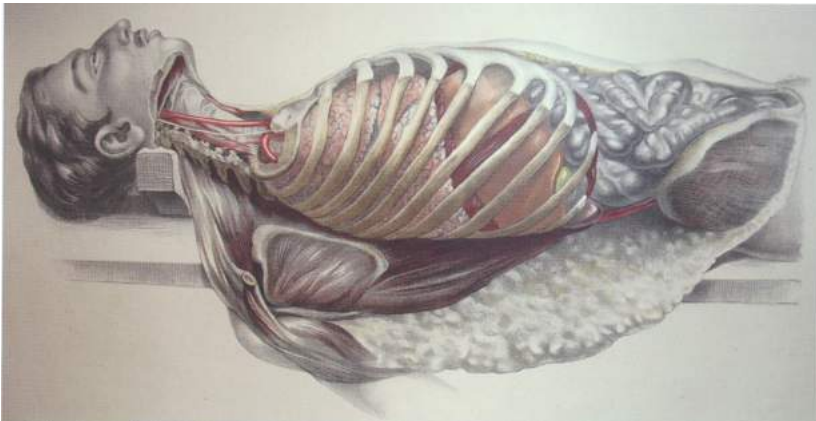

Figure 216. Illustration showing ribs, organs and blood vessels, colored lithograph by William Fairland from Francis Sibson, *Medical Anatomy* (London, 1869)

Source: Elizabeth Hallam, *Anatomy Museum: Death and the Body Displayed* (London: Reaktion Books, 2016), 164



Figure 217. A female torso with opened uterus and foetus, c.1770 made for William Hunter

Source: Hallam, *Anatomy Museum: Death and the Body Displayed*, 127

4.4.3. The Architectural Cut: Section

“Architecture has always followed medicine. During the Renaissance, for example, when doctors investigated the mysterious interior of the body by cutting into and dissecting it, architects tried to understand the interior of the building by slicing section cuts through it.”⁶³³

As both the architectural artefact and the human body are self-enclosed entities with complex interiors, the analytic preoccupation underlying their study employs the techniques of “cutting” which enable seeing through outer surfaces into deeper structures. Considering the detailed description of the medical gaze made in Chapter 2.2.1, it is possible to claim that the medical gaze is homologous with the

⁶³³ Colomina, “Skinless Architecture.” 123

“architectural gaze” in terms of having the power to go beyond the visible surface and spatially analyze the complex interiors.

Before discussing the immediate similarities established between architectural section drawings and the illustrations of dissected bodies that have been vastly mentioned and studied by prominent architects, physicians and philosophers, the critical art practice of Gordon Matta-Clark could be analyzed in relation with the dissection of the human body.

Between 1971 and 1978, Matta-Clark produced a body of work known as the “building cuts: sculptural transformations of abandoned buildings paradoxically constructed through the cutting and virtual dismantling of a given architectural site.”⁶³⁴ Among these work “Conical Intersect” made for the Paris Biennial of 1975, which consisted of deep cone-shaped cuttings into two seventeenth-century buildings, already designated for demolition, draws attention. These radical incisions through the buildings that were about to be knocked down in the working class neighborhood of Les Halles in Paris, near much-contested Centre Pompidou, was a critique of urban gentrification.⁶³⁵ In his interview, Matta-Clark commented about his work as follows:

“The first thing one notices is that violence has been done. Then the violence turns into visual order and, hopefully, then to a sense of heightened awareness. [...] You see that light enters places it otherwise couldn’t. Angles and depths can be perceived where they should have been hidden. Spaces are available to move through that were previously inaccessible. [...] My hope is that the dynamism of the action can be seen as an alternative vocabulary with which to question the static, inert building environment.”⁶³⁶

⁶³⁴ Pamela M. Lee, “On the Holes of History : Gordon Matta-Clark’s Work in Paris,” *October* 85 (1998): 65–89, <http://www.jstor.com/stable/779183>. 65

⁶³⁵ “Gordon Matta-Clark Conical Intersect,” accessed July 8, 2020, <https://www.guggenheim.org/artwork/5211>.

⁶³⁶ Bruce Jenkins, *Gordon Matta-Clark: Conical Intersect* (London: Afterall Books, 2011).40 quoted in Peio Aguirre et al., “The Persistence of Geometry, Exhibition Catalogue,” *Contemporary Art Collections of “la Caixa” Foundation and MACBA* (2011).78

Matta-Clark's cut could be considered as a spatial intervention towards the self-enclosed architectural entity that is conceptually quite similar to the anatomical dissection which disrupts the integrity of the human body, revealing its interior space. Although Matta-Clark created *Conical Intersect* with different motives, his work could be considered as the product of an analytical mind and a reflection of medical-architectural gaze desiring to unveil the concealed spaces, thus the hidden knowledge. (Fig. 218-219)

In addition, Matta-Clark's work suggested a radical manipulation of the boundary separating the public from the private. The interior space of a building, which is normally regarded as an intimate and inaccessible zone was undisclosed through the gigantic hole created within the architectural body. In Nancy Spector's words, "[p]eriscopelike, the void offered passersby a view of the buildings' internal skeletons."⁶³⁷ Just like the anatomical dissection inviting people to the private inner space of the body, Matta-Clark's installation welcomed the curious public eye to the intimate interior of an architectural artefact. As expressed by the artist himself:

"I began with a summer of cutting openings into walls and floors that had been staunch defenders of other people's privacy or isolation. By penetrating the layers that divided one family's limited surface reality from another's, their simple proximity was heightened. A spatial reality was emphasised that the private pleasures and hells of earlier residents would have never allowed."⁶³⁸

At this point, it is important to mention that while discussing the anatomical illustration of Fritz Kahn, named "The Oxygen Cycle," Sappol referred to the concepts of public and private space (Fig. 152):

"That exposure of the 'interior space' points to an odd metamorphosis that Kahn wants to orchestrate: the interior of the body is converted into a

⁶³⁷ "Gordon Matta-Clark *Conical Intersect*."

⁶³⁸ Gordon Matta-Clark, *Works and Collected Writings*, ed. Gloria Moure (Barcelona: Polígrafa, 2006), p. 141. quoted in Peio Aguirre et al. *Contemporary Art Collections of "la Caixa" Foundation and MACBA, The Persistence of Geometry*. (Barcelona: "la Caixa" Foundation, 2011), Exhibition catalogue. 78

schematic public space, open for inspection, like a model manufacturing plant open for tours, or on exhibition.”⁶³⁹

In that sense, it is possible to claim that Conical Intersect shared similar characteristics with dissection practice and anatomical section drawings, within the context of “cutting”. (Fig. 214-215)



Figure 218. Gordon Matta-Clark, Conical Intersect, 1975

Source: Frances Richard, “Spacism,” accessed July 8, 2020, <https://placesjournal.org/article/gordon-matta-clark-spacism/?cn-reloaded=1>.



Figure 219. Gordon Matta-Clark, Conical Intersect, 1975

Source: “Gordon Matta-Clark,” Artforum, accessed July 8, 2020, <https://www.artforum.com/print/previews/200701/gordon-matta-clark-12276>.

As argued by Beatriz Colomina, for centuries both medicine and architecture has been practiced, studied, and communicated through sectioning. “Dissection” in medicine corresponds to “section” in architecture and both concepts have performative, representational and display-related dimensions. This powerful link between architecture and medicine established through dis(section) is most evidently

⁶³⁹ Strange Spaces: Explorations into Mediated Obscurity, ed. André Jansson, Amanda Lagerkvist (Farnham: Ashgate Publishing, 2009), 88

embodied in Renaissance works. Within this context, the studies of Leonardo Da Vinci are worth mentioning. It has been claimed that Da Vinci employed the techniques of architectural surveying to his anatomical depictions of the human body.

“In the sketchbooks of Leonardo da Vinci, cutaway views of architectural interiors appeared beside anatomical drawings. He understood the interiors of the brain and womb in architectural terms, as enclosures that must be cut through to reveal their secrets.”⁶⁴⁰



Figure 220. Leonardo Da Vinci, Embryo in the Womb, ca. 1510

Source: Beatriz Colomina, *X-Ray Architecture* (Altenburg: Lars Müller Publishers, 2019), 14

⁶⁴⁰ Colomina, “Skinless Architecture.” 123

As Colomina argues, in the mid-nineteenth century, the illustrations of Viollet-le-Duc in his *Dictionnaire raisonné de l'architecture française du XI^e au XVI^e siècle* (1854-1868) included perspectival sectional cutaway drawings of medieval buildings, representing them just like a dissected body. She wrote as follows:

“Influenced by George Cuvier’s *Lecons d’anatomie compare* (1800-1805) and Jean-Marc Bourgery’s *Traite complet de l’anatomie de l’homme, comprenant la medecine operatoire* (1830-1849) he treated medieval architecture as a body to be analysed -an ‘inanimate being’ requiring ‘dissection’ to allow separate study of its parts. His new mode of drawing revealed the functional role of each dissected fragment. His own interventions into medieval buildings were understood as surgical procedures, with modern iron technology used as prosthesis.”⁶⁴¹

In addition, the cut pieces in the illustration of Viollet-le-Duc giving the sensation that they are about to fall could be considered as a reference to the performative aspect of sectioning process.

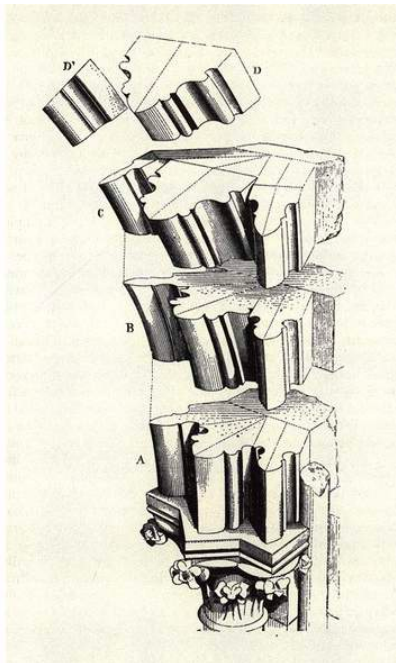

Figure 221. Sliced medieval building part in *Dictionnaire raisonné de l'architecture française* by Viollet-le-Duc (1854-1868)

Source: Colomina. *X-ray Architecture*, 15

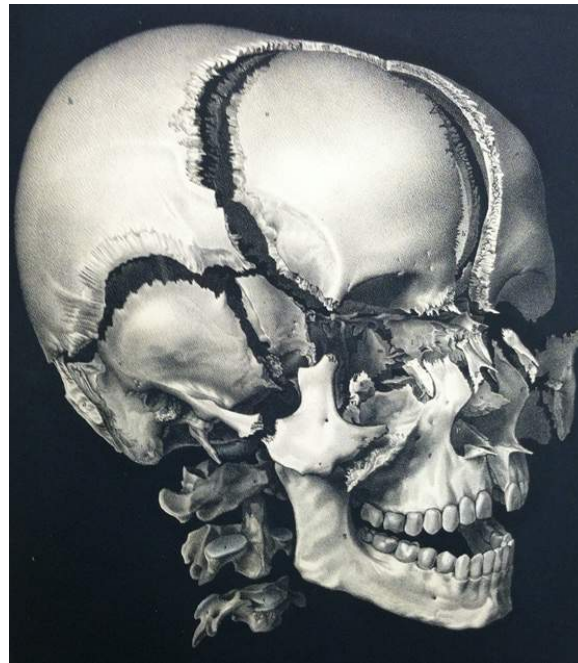

Figure 222. Exploded view of the skull, in *Traite complet de l'anatomie de l'homme comprenant la medecine operatoire* by Jean-Baptiste Bourgery, Paris, 1831

Source: Colomina. *X-ray Architecture*, 15

⁶⁴¹ Colomina, *X-Ray Architecture*.15

When the overlaps between architecture and medicine are explored within the context of “cutting”, it becomes necessary to put a specific emphasis on the method of “sequential sectioning”. The tradition of studying anatomy through a series of sections dates back to the Renaissance period. Among the impressive sketches of Da Vinci, there were drawings depicting specific parts of the body as sliced into successive pieces. (Fig. 223)

In 1818, Dutch anatomist Pieter de Riemer published an atlas of human transverse sections that included the visuals of specimens obtained by freezing the cadaver. Decades later, Nicholas Pirogoff, a renowned Russian anatomist and surgeon, produced cross-sectional specimens with a similar fixation method and published them in a five-volume book between 1852 and 1859. He described his technique as a novel method “by which the human body could be cut like wood into thin sections.”⁶⁴² Towards the end of the 19th century German anatomist Wilhelm Braune improved and promoted the technique. (Fig. 224) The vast use of this approach has been a result of the understanding that “slices could translate the three-dimensional complexity of organic structures into flat, easy-to-read specimens, which then could be preserved or drawn by an artist.”⁶⁴³

⁶⁴² Sappol, *Dream Anatomy*. 130

⁶⁴³ Sappol. 156

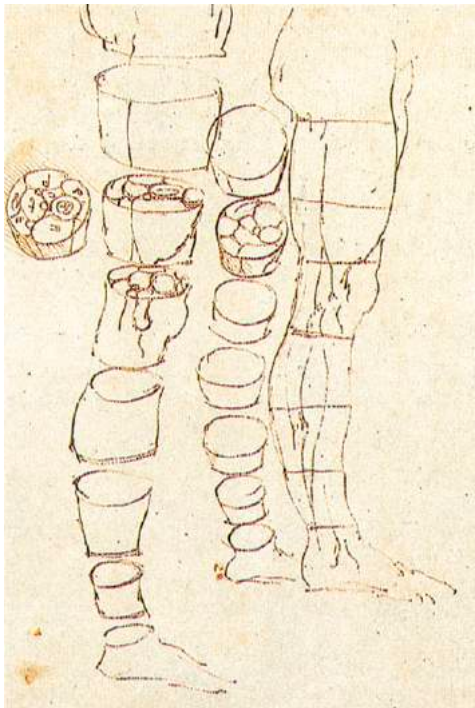

Figure 223. The right leg of a man cut into sections by Leonardo Da Vinci

Source: Adrian K. Dixon et al., *Human Sectional Anatomy: Atlas of Body Sections, CT and MRI Images* (CRC Press, 2015), viii

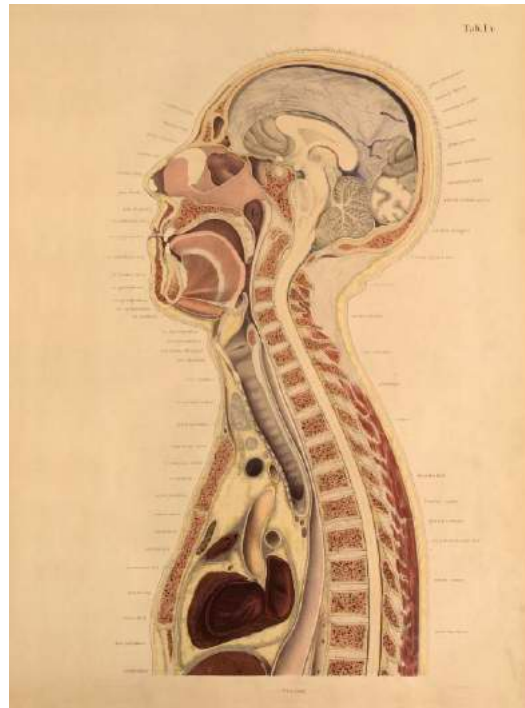

Figure 224. Chromolithograph by C. Schmiedel in *Topographisch-anatomischer atlas nach durchschnitten an gefrorenen cadavern*, Wilhelm Braune Leipzig, 1872.

Source: Michael Sappol. *Dream Anatomy*, 131

“The Visible Human Project” initiated in 1989 by the National Library of Medicine epitomizes a recent implementation of this deep-rooted technique. The major goal of the project was to create a “comprehensive digitized library” of the human body by using frozen cross sections. A male and a female cadaver were scanned with using CT (computerized tomography) and MRI (magnetic resonance imaging). The bodies, deep frozen in blue gelatin, were then processed to remove thin cross sections of tissue from head to toe. As each layer was revealed, the surface was digitally photographed, generating a data that could be reorganized, navigated and manipulated with computer software.”⁶⁴⁴ (Fig. 225) The method of sequential sectioning is also employed by Gunther von Hagens and displayed in “Body Worlds and the Cycle of Life” exhibition. (Fig. 226)

⁶⁴⁴ Sappol. 156



Figure 225. Photographs from Visible Human Project

Source: Sappol, *Dream Anatomy*, 156



Figure 226. The sliced body cross section display at The Body Worlds and the Cycle of Life exhibition at Telus World of Science in Edmonton, photo by Graeme Archibald, 2013

Source: Graeme Archibald, "Body Worlds Returns to the TELUS World of Science," accessed July 8, 2020, <https://thewandereronline.com/body-worlds-returns-by-graeme-archibald/>.

“Just as medical technologies and the treatment of illness played a major role in determining the characteristics of modern architecture, new medical technologies are today creating new forms of architecture as the relationship between inside and outside passes through another transformation.”⁶⁴⁵

Recent technological developments have altered the ways that human body is studied and enhanced the anatomical knowledge. Until the invention of X-ray imaging, sonograms, tomography, CAT scans, MRIs, the only way to see the corporal space was through dissection. Thanks to these technologies, it is possible to visualize the intricate internal structure of the body without the harming its integrity. Colomina argues that:

“At the turn of the twenty-first century, the CAT scan (Computerized Axial Tomography) may be for us what the basic X-ray was for architects early in the twentieth century... As with the X ray, architects have been quick to respond to the new technology. If architectural publications at the beginning and middle of the century were full of X rays, contemporary architectural publications are full of cat scan images.”⁶⁴⁶

As claimed by Colomina, the idea behind the working mechanism of a CAT scan bears resemblance to the architectural understanding of the 21st century. Simply, a CAT scan is the compilation of many X-ray images by a computer to generate cross-sectional views and volume renderings and of the corporal space. CAT technology first slices the body in sequence and then reconstructs these slices to obtain a three-dimensional virtual body. In fact, not only the CAT scan but also MRI, tomography and many other medical visualization devices create images through the method of serial sectioning. The section-based thinking behind the operating principle of the 21st century medical imaging devices is found in many theoretical and practical architectural works.

⁶⁴⁵ Colomina, *X-Ray Architecture*.

⁶⁴⁶ Colomina, “Skinless Architecture.” 124

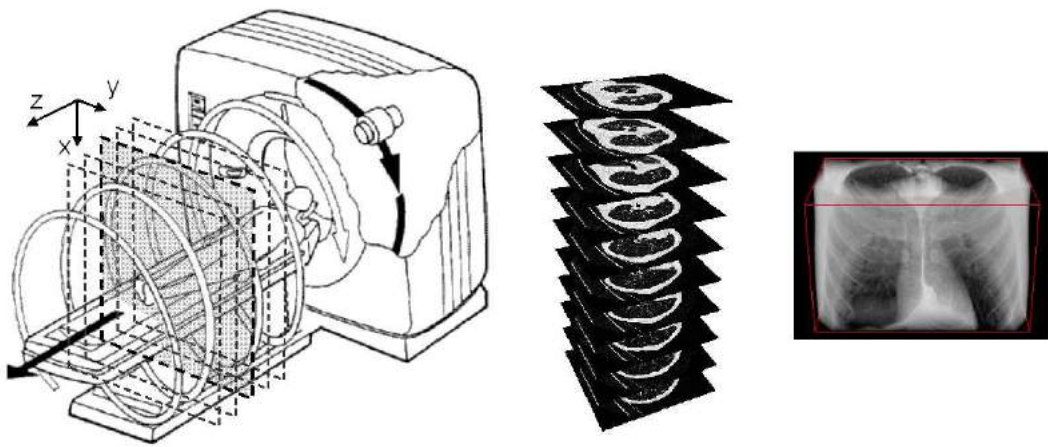

Figure 227. Principle of volumetric image acquisition in CT.

Source: C. I. Fetita et al., "Techniques in Computer-Aided Diagnosis and Their Application in Clinical Investigation of Bronchial Systems," *Biomechanical Systems Technology*, 2007, 117–66, 3

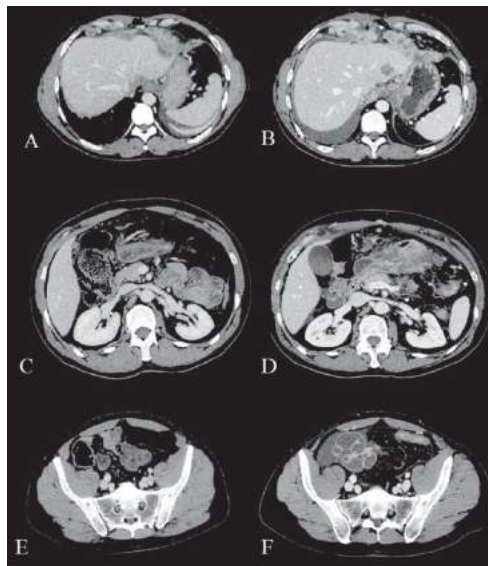

Figure 228. Computerized axial tomography (CAT) scans.

Source: Laura Caggiari, et al. "A new mutation of the CDH1 gene in a patient with an aggressive signet-ring cell carcinoma of the stomach." *Cancer Biology & Therapy* 19, no. 4 (2018), 254-259.



Figure 229. Multiple X-ray computed tomographs

Source: "Multiple X-Ray Computed Tomographs," accessed July 8, 2020, <https://en.wikipedia.org/wiki/Tomography>

For instance, on the cover of the catalogue prepared for the exhibition in the Architekturgalerie Luzern in 1992 that comprises Jose Luís Mateo’s recent work, there is a CAT scan image of a brain to emphasize the idea that “ the architect has to act with the callousness of the medic: he cuts, analyses, researches.”⁶⁴⁷

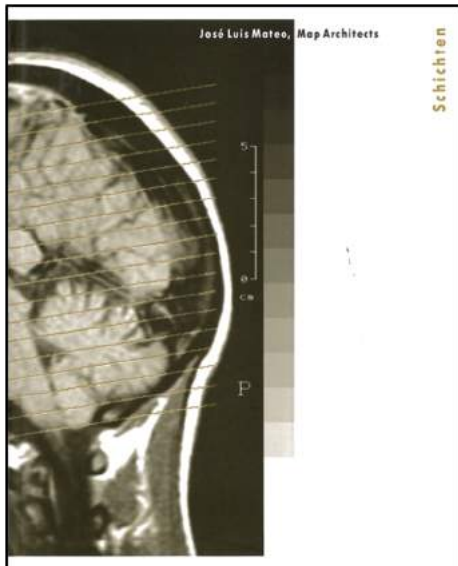

Figure 230. Jose Luís Mateo, Ed. Architekturgalerie. Luzern, 1992.

Source: “Schichten,” accessed July 8, 2020, <https://www.mateo-arquitectura.com/publications/schichten/>.

A striking example to the concept of sequential sectioning in architectural design is Yokohama Port Terminal by Foreign Office Architects (FOA) completed in 2002. As written by Colomina, the project seems to follow the logic of the CAT scan in terms of creating an endless series of section cuts that is used to generate a three-dimensional body. “The building aspires to be a continuously folded surface where structure and skin are one, and there are no bones or discrete organs.”⁶⁴⁸

As mentioned by Alper Alkan, FOA’s approach was based on the idea of creating an “architecture of organic and flowing spaces.”⁶⁴⁹ This means that, the spatial

⁶⁴⁷ Colomina. 124

⁶⁴⁸ Colomina. 124

⁶⁴⁹ Alkan, “Framing the ‘Invisible’: Section as a Spatial Frame for a Reconsideration of Architectural Representation.” 92

complexity of the building coming from the aim of generating organic spaces was overcome in the design process through sequential sectioning, similar to the working principle of CAT scan, or other medical imaging devices that decipher the highly complex corporal space in terms of creating successive sections. In other words, the method of serial sectioning provides the opportunity to better study, analyze and understand the complex bodies.

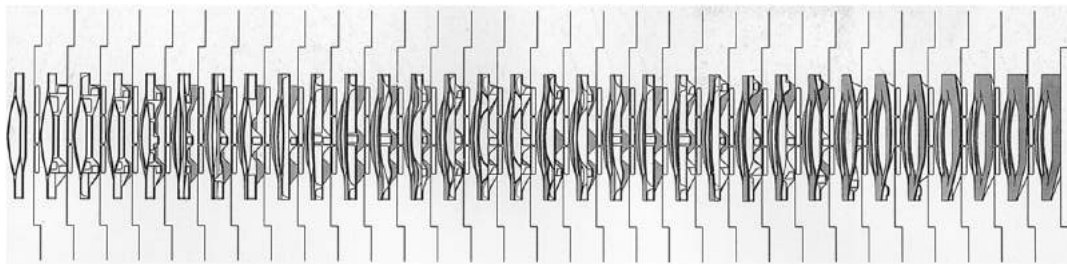

Figure 231. Transversal sections of Yokohama International Port Terminal, Foreign Office Architects.

Source: Foreign Office Architects, "National Glass Centre, Sunderland / Redevelopment Of Cartuja Island, Seville / Yokohama International Port Terminal," *AA Files*, no. 29 (1995): 7–21, 16

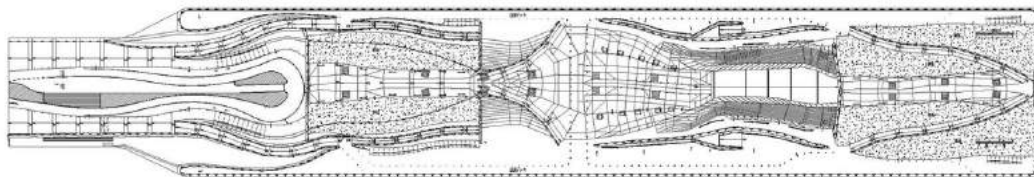

Figure 232. Observation deck plan of Yokohama International Port Terminal, Foreign Office Architects.

Source: David Langdon, "AD Classics: Yokohama International Passenger Terminal / Foreign Office Architects (FOA)," *ArchDaily*, accessed July 8, 2020, <https://www.archdaily.com/554132/ad-classics-yokohama-international-passenger-terminal-foreign-office-architects-foa>.



Figure 233. Suspended Self Portrait by Carolyn Henne. Sculpture installation. 2001, photo by Travis Fullerton

Source: Sappol, *Dream Anatomy*, 159

4.5. Fragments

4.5.1. (Dis)membering

“Divide each difficulty into as many parts as is feasible and necessary to resolve it.”⁶⁵⁰

“...body no longer serves to centre, to fix or to stabilize. Its limits, interior or exterior, seem infinitely ambiguous and extensive; its forms, literal or metaphorical, are no longer confined to the recognizably human, but embrace all of human existence, from the embryonic to the monstrous; its power lies no longer in the model of unity, but in the intimation of the fragmentary, the morsellated, the broken.”⁶⁵¹

Each component of the human body is highly specialized and autonomous up to a point, nevertheless all these members constitute the pieces of a complex whole, functioning as a flawless system. For instance, heart is an organ that has an individual working mechanism and “meaningful” by itself, but it is a part of the circulation, or cardiovascular system consisting of other important members: lungs, arteries, veins and vessels. On the other hand, lungs do not only participate in the cardiovascular system but also constitute the major elements of the respiratory system which includes structures other than lungs such as larynx, trachea, bronchi and alveoli. This example shows that there are independently, yet interdependently working systems in the body, to keep it alive and healthily functioning. Regarding that, the human body is studied, taught and treated in parts. The numerous specialties in medicine such as cardiology, hematology, endocrinology, gastroenterology, urology and dermatology that have established since ancient times prove this argument. In this framework, dismembering have become a fundamental method in anatomical display.

⁶⁵⁰ René Descartes, *Discourse on Method and the Meditations* (Penguin Books, 1968).

⁶⁵¹ Vidler, “The Building in Pain: The Body and Architecture in Post-Modern Culture.”³

Together with the primary act of opening up the body through incision with scalpel, dismembering constitutes the essence of cadaveric dissection. In better terms, dissecting has always been accompanied with the dismemberment of the body. Without dismembering, cutting by itself would be incompetent and inefficient for understanding the complex interiors of the body. Dismembering provided the opportunity to see and study the organs in isolation, detached from their complex and “messy” context. (Fig.237) Similar to the method of dissecting, dismembering is also represented through manifold media.

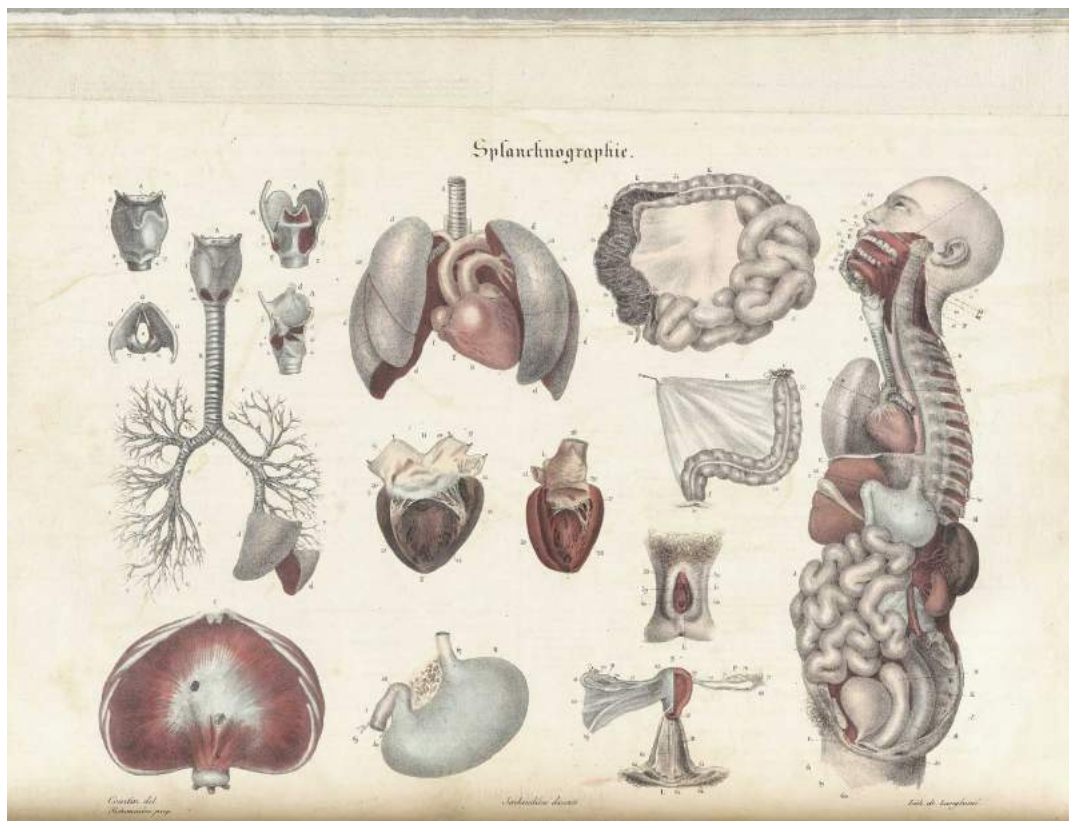

Figure 234. Chromolithograph by Louis Courtin in Jean-Baptiste Sarlandière, *Anatomie méthodique, ou Organographie humaine en tableaux synoptiques, avec figures* (1829)

Source: Sappol, *Dream Anatomy*, 48

The most remarkable implementation of this method is the dismantlable anatomical models. Anatomical Venus exhibited in Natural History Museum of Florence, attributed to the famous wax model artist Clemente Susini (1754-1814) is a

prominent example of detachable anatomical models. (Fig. 235-236) Messbarger described the anatomical Venus as follows:

“First envisioned intact, as an extra life-like Venus, recumbent on an actual silk bed, with polished skin, glass eyes lost in a voluptuous trance, a pearl necklace, and flowing human hair, her breastplate was, in her second stage of viewing, removed to reveal the regular straight lines and angles of the thoracic and anatomical walls and surface musculature, and the neat mound of serpentine mammary glands of the left breast. In the third revelation, the left breast was detached and could be held in hand. The fourth view exposed the thick petalled lobes of the lungs and the anterior surface of the heart gracefully folded within the thoracic cavity, as well as the omentum covering the organs of the lower abdomen. In the fifth viewing, the lungs and omentum were removed to reveal the fruit and vessels of the heart as well as the ordered mass of intestines in the abdominal cavity. Next, the intestinal tract was extracted to show the colourful and tidy contents of the lower abdomen: the liver, stomach, duodenum, symmetrical kidneys, uterus with ovaries and abdominal aorta. In the final, most profound vision, select organs were opened to show their internal structures and contents: the heart, the stomach and duodenum, and the uterus, in which nestled a perfect curled up foetus.”⁶⁵²

The Florentine Venus with all its intricate anatomical systems and parts was designed for orderly hands-on disassembly and reassembly in order to enable an “orderly” hands-on disassembly and reassembly of the body. By epitomizing the ideal practical means, it suggested a new accessibility to the “true” knowledge of the human anatomy within the scientific context of late-eighteenth century. “The demountable anatomical Venus was, of course, the most transparent expression of the physics of the body and the most sublime.”⁶⁵³

⁶⁵² Messbarger, “The Re-Birth of Venus in Florence’s Royal Museum of Physics and Natural History.” 16

⁶⁵³ Messbarger. 14



Figure 235. Anatomical Venus probably modeled by Clemente Susini, c.1790 at Natural History Museum of Florence, Italy

Source: “Henry Wellcome’s Anatomical Venus,” accessed July 8, 2020, <https://wellcomecollection.wordpress.com/2014/11/25/henry-wellcomes-anatomical-venus/>.

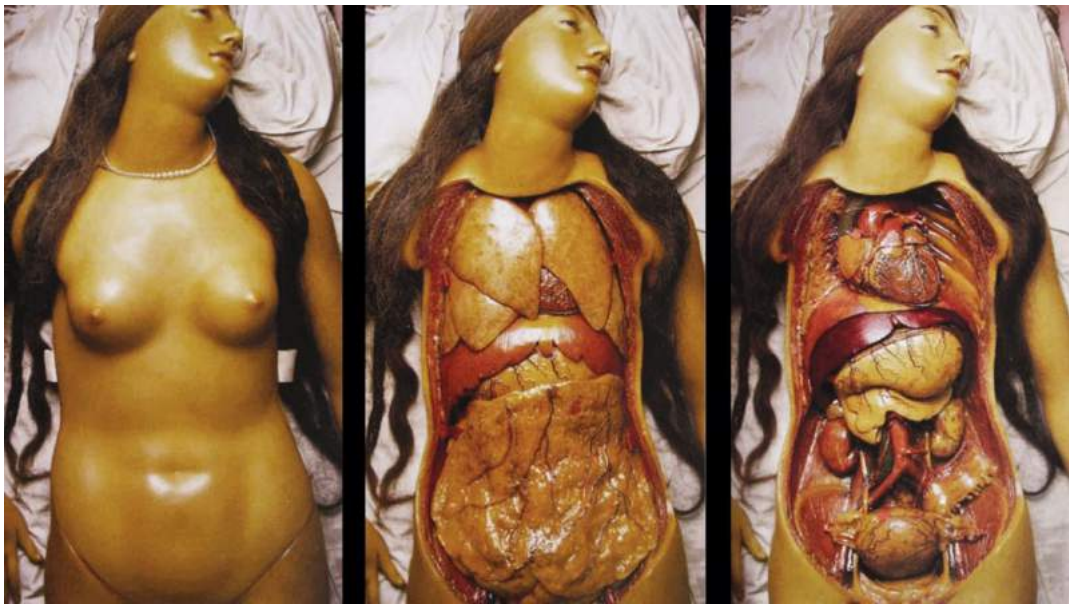

Figure 236. Anatomical Venus at Natural History Museum of Florence in various stages of dissection. Photos by Saulo Bambi, as seen in Taschen’s Encyclopedia Anatomica.

Source: “Henry Wellcome’s Anatomical Venus,” accessed July 8, 2020, <https://wellcomecollection.wordpress.com/2014/11/25/henry-wellcomes-anatomical-venus/>.



Figure 237. Anatomical Venus in Wellcome Collection, probably made at the workshop of Clemente Susini and Francesco Calenzuoli in Florence between 1776 and 1780.

Source: “Henry Wellcome’s Anatomical Venus,” accessed July 8, 2020, <https://wellcomecollection.wordpress.com/2014/11/25/henry-wellcomes-anatomical-venus/>.

Models that could be repeatedly taken apart and fitted back together became popular during the nineteenth century. The models created by Louis Auzoux (1797-1880) were widely distributed to the medical schools in Britain, Europe, North America, Australia, India, Egypt and Japan and constituted the prototype for the commonly used plastic detachable models that were began to be manufactured from the mid-twentieth century onwards. Auzoux developed the concept of *anatomie clastique* (clastique anatomy), the French word *clastique* coming from the Greek term *klastos*, meaning “broken in pieces”, that was reflected on his models. The models were composed of multiple components that could be disassembled to show the internal parts of the body, as in a “real dissection” and then, smoothly reassembled.⁶⁵⁴

⁶⁵⁴ Hallam, *Anatomy Museum: Death and the Body Displayed*. 289

The repetitive disassembly and reassembly of the parts of the anatomical figure produced the unequivocal knowledge of the human body. “To take apart and put back together, to analyze and synthesize, is to know.”⁶⁵⁵

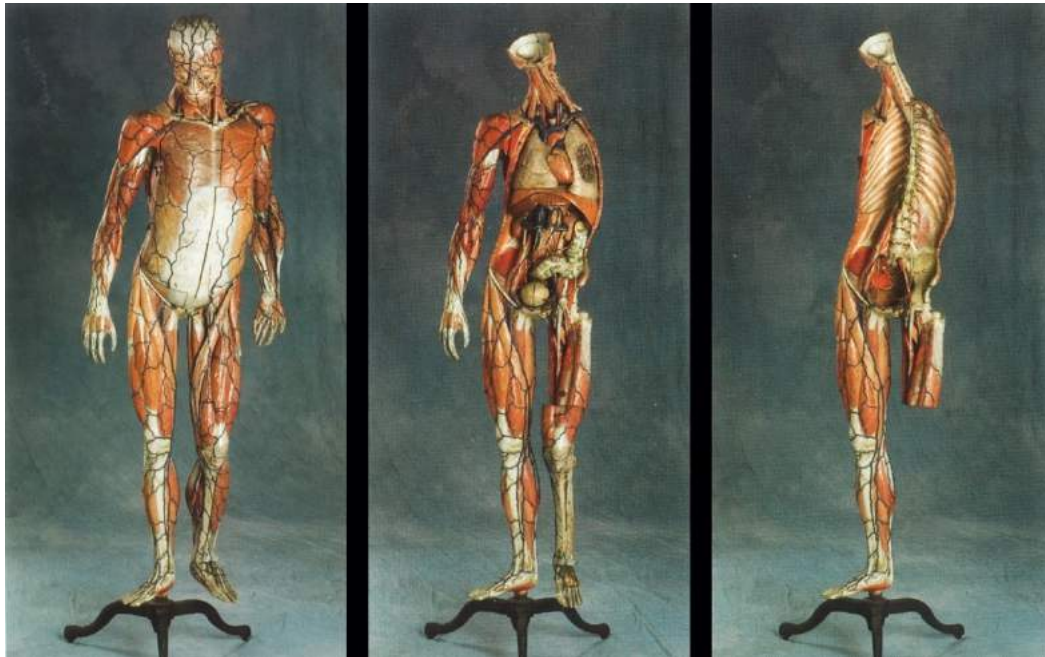

Figure 238. Anatomical model by Louis Auzoux, 1879, Paris

Source: Elizabeth Hallam, *Anatomy Museum: Death and the Body Displayed* (London: Reaktion Books, 2016), 290-91

⁶⁵⁵ Messbarger, “The Re-Birth of Venus in Florence’s Royal Museum of Physics and Natural History.”

4.5.2. Dismembered Body Re-membered⁶⁵⁶ in Museum Space

Michel de Certeau referred to two basic operations that characterize the interventions to the body:

“One is concentrated on removing an element from the body, the superfluous, diseased, or unaesthetic, or adding to the body whatever it might be missing. The instruments differ according to the task for which they are implemented: cutting, tearing out, removing, taking away, etc., or inserting, placing into, gluing onto, setting on top of, assembling, sewing, fitting together, etc.- not to mention the things which replace missing or damaged organs...”⁶⁵⁷

As previously mentioned, it is not possible to understand the complex organization and functioning of the body at once, as a whole. Therefore, the human body is studied, visualized and displayed in fragments. The anatomical displays include various objects in different media: dry and wet specimens, illustrations, photographs and models... The constellation of objects depicting the human body or pieces belonging to deceased bodies along with the texts that framed them are coalesced in the space of the anatomy museum.

All these objects represent a specific organ, system, part or layer of the body, none of them depicts the body as a whole, completed and intact entity. It is possible to consider each display object as an individually “meaningful” fragment, removed from its bodily context. In the museum space, all of these pieces that are detached from their whole(s) are brought together to create a new whole, a novel body. In better terms, the dismembered body is re-membered in the museum space.

For instance, John Hunter’s museum at the Royal College of Surgeons in London includes seven thousand museum items including multiple specimens of individual body parts together with drawings, paintings and skeletons. As written by Berkowitz, collections like Hunter’s, “combining both specimens of the same body part in series

⁶⁵⁶ The dual concept of “Re-membering” is derived from Brandstetter, *Rememb. Body*.

⁶⁵⁷ Brandstetter.18

to show variation of that part across a species and specimens of different body parts represent the total organism.”⁶⁵⁸



Figure 239. Anatomical specimens in jars in John Hunter’s museum at the Royal College of Surgeons in London

Source: “Fiona Bruce’s Britain: The Hunterian Museum, London,” The Telegraph, accessed July 8, 2020, <https://www.telegraph.co.uk/travel/destinations/europe/united-kingdom/england/london/articles/Fiona-Bruces-Britain-The-Hunterian-Museum-London/>.

In fact, the practices of “dismembering” and “re-membering” not only define the museum space but also constitute the essence of anatomical scholarship. Considering the role of anatomy museum in anatomical teaching, it is no coincidence that the approach underlying the anatomy education is similar to the understanding shaping the anatomical display.

“Although student learned anatomy in ‘pieces’, these had to be fitted together so that the relations between them could be visualized and the body understood, in terms of structure and function, as a ‘single unit’.”⁶⁵⁹

⁶⁵⁸ Berkowitz, “Systems of Display: The Making of Anatomical Knowledge in Enlightenment Britain.”372

⁶⁵⁹ Hallam, *Anatomy Museum: Death and the Body Displayed*.50

The experience of the medicine student, as described by Hallam, becomes the experience of the audience of the anatomical display. The fragments from dismembered bodies disposed in the museum space come together and integrate in the mind of the visitor and generate a “perceptual body” that is fully complete. The mental model created in mind through the assembling of various corporal pieces paves the way for the production and piercing of anatomical knowledge.

““Remembering the body” touches on the complex subject of the memory of the body and of movement and the concomitant processes of remembering and forgetting. And at the same time, “re-membering the body” signifies the dismantling of the body and its reassembly, and thus also refers to the specifically Western problem that has existed since the Renaissance: that of the subject and of corporeal identity.”⁶⁶⁰

It is possible to relate this dual concept of remembering to the anatomy museum experience. The mental creation process of the body from the body fragments on display could be considered as a practice of “re-membering”. Although the similarity between “re-membering” and “remembering” may seem like a simple wordplay, in fact, these two are distinct, yet highly related concepts. Re-membering is gathering the fragments of something together, while remembering is recalling past experiences. In a way, both refer to the recollection of the related parts of a whole.

“Helping students to understand the anatomy of an integrated whole, then, the Anatomy Museum-which could be surveyed within one space as a (seemingly) complete set of regions- aided in this task of mentally assembling the body parts explored in the dissecting room.”⁶⁶¹

At this point, it becomes relevant to mention about the ancient notion of “*dissecta membra*” to better understand this dismembering and re-membering process taking place in the museum space. The phrase means “scattered fragments” in Latin where “fragments” may refer to limbs, members or remains, depending on the context. The

⁶⁶⁰ Brandstetter, *Rememb. Body*.16

⁶⁶¹ Hallam, *Anatomy Museum: Death and the Body Displayed*.332

expression is especially used to refer to the surviving fragments of a written work such as poetry and manuscripts. It is derived from the phrase *disjecti membra poetae*, meaning “limbs of a dismembered poet” used by the Roman lyric poet Horace. The phrase suggests that if a poetic work is dissected and rearranged, the dismembered parts of the original work might be still recognizable and often used to describe the piecing together of ancient fragments of a literary work.⁶⁶²

According to an ancient Egyptian myth, the body of the god Osiris was dismembered and scattered over the land by Seth. Then the goddess Isis gathered the dispersed limbs, *disjecta membra*, and fitted them back together to reconstruct the body, thereby bringing it back to life. As stated by Brandstetter, “in the myth of Osiris, a figure of memory unfolds as a process of the fragmentation and the re-collection of the body.”⁶⁶³

Isis is the goddess of wisdom and knowledge and the Greek philosopher Plutarch interpreted her search for the scattered limbs of dismembered Osiris as an allegory of the unfinished philosophical project of the search for truth.⁶⁶⁴ In terms of embodying the relationship between re-membering and the acquisition of knowledge, the myth of Osiris becomes a metaphor for the epistemological value of the dismembering and remembering process occurring in the anatomy museum.

The ancient Egyptian mummification tradition also refers to a similar concept. During the embalming process, the internal organs, especially lungs, liver, intestines, and stomach were removed and placed in separate canopic jars to prevent the decay of the body. It was believed that the embalmed body and the organs would piece together and function in afterlife. In that sense, the meaning of embalment and mummification is not only the conservation of the corpse, but rather “the

⁶⁶² Lyna Ayr, “Disjecta Membra: A Poetic Interplay of Fragments” (Master’s Thesis, Auckland University of Technology, 2013).

⁶⁶³ Brandstetter, *Rememb. Body*.22

⁶⁶⁴ Assmann, “Body, Text, Transcendence.”78

reintegration or reconstruction of the person.”⁶⁶⁵ Within this context, it is possible to compare this ancient practice to the remembering process of the dismembered body in the museum space.

As discussed in chapter 2.3.5, the body normally stands for the tangible, material and corporeal but according to ancient Egyptian belief, after being re-membered in afterlife, it becomes the symbol of the mental and the spiritual.

“The body is the symbol and carrier of the biographical past in which the person of the deceased has matured to a final form in which he would like to enter eternity. Thus, the body symbolises a biographical memory, the sum and repository of experiences amassed during life which constitute the nature, character, and identity of the deceased...”⁶⁶⁶

Likewise, in the anatomy museum while the dismembered bodies on display refer to the material/carnal aspect of the body, the mental process of remembering reveals the immaterial aspect of the body, its knowledge.

As argued by Fredrika Jacobs, in art, the perfection of the corporal figures was achieved through the method of disassembling and reassembling.⁶⁶⁷ The dissection of the body was considered to be an essential step in the creative process. The disintegration of the human body “facilitated the construction of another in the myriad materials of art.” Although the dissection and disassembling played a significant role, ultimately, disassembling had as its goal reassembling. Many sixteenth-century theorists and artists understood and defined composition (*compositio*, *componimento*) in the literal sense, as the assembly of parts. In better terms, the dissection and the taking apart of or borrowing from esteemed works of

⁶⁶⁵ Jan Assmann, “Re-Membering Osiris: From the Death Cult to Cultural Memory,” in *ReMembering the Body*, ed. Hortensia Völckers and Gabriele Brandstetter (Ostfildern-Ruit: Hatje Cantz Publishers, 2000), 42–78.46

⁶⁶⁶ Assmann.46

⁶⁶⁷ Fredrika Jacobs, “(Dis)Assembling: Marsyas, Michelangelo, and the Accademia Del Disegno,” *The Art Bulletin* 84, no. 3 (2002): 426–48, <http://www.jstor.org/stable/3177307>.

art and the subsequent integration of these disparate parts constituted another whole, or *compositio*.⁶⁶⁸

The creation process of Zeuxis' legendary painting of Helen, recorded by Pliny and well-known among Renaissance theorists and artists embodies the method of dismembering and remembering in classical art. Jacobs tells the story as follows:

“Commissioned to paint an image of the woman whose famed beauty triggered the events that erupted in the Trojan War and eventually led to the founding of Rome, Zeuxis demanded that every maiden in the city of Croton be brought before his scrutinizing eyes. From the assembled girls he selected five he deemed to have some feature of singular loveliness. He extracted from each some particularly beautiful feature or features and reconfigured these into a composite that became his painted Helen. Through his method of first disassembling, then reassembling, Zeuxis had done what nature could not—he had made a figure of perfection.”⁶⁶⁹

The compositional method employed by Zeuxis, based on the disintegration of the body and then its creative assemblage, was highly used in art schools.

“First, they cut out images of the body's individual organs and systems printed on separate sheets. This done, they pasted the pieces together on another sheet in order to make a reassembled whole.”⁶⁷⁰

The concept of fragmented body, the practices of dismembering and remembering were also present in the art practice of the early 20th century. Vidler wrote on this subject as follows:

“Cubist and post-cubist attempts to dismember the classical body in order to develop an expressive model of movement were thus dedicated, not so much to its eradication, but to its re-formulation in modern terms. From Duchamp's *Nude Descending a Staircase* (1912), based on Etienne-Jules Marey's careful studies of movement, to Balla's *Woman with a Dog on a Leash* (1912), there seems to be no fear that the body is entirely lost: rather, the question is one of representing a higher order of truth to perception of movement, forces and repose. Even in that 'primal scene', the 'Overture' to Proust's *Remembrance*

⁶⁶⁸ Jacobs.

⁶⁶⁹ Jacobs. 442

⁶⁷⁰ Jacobs. 442

of Things Past, where Marcel, on awakening, figures the parts of his body according to their successive positions during the night, as if seen on a bioscope - the instrument invented by Muybridge to analyse the running positions of the horse, even this fragmented body is ready at any instant to be recomposed, as Proust observes, into the 'original components' of the ego."⁶⁷¹



Figure 240. Marcel Duchamp, *Nude Descending a Staircase, No. 2*, 1912

Source: "Marcel Duchamp, *Nude Descending a Staircase, No 2*," accessed July 8, 2020, <https://www.khanacademy.org/humanities/art-1010/dada-and-surrealism/dada2/a/marcel-duchamp-nude-descending-a-staircase-no-2>.

⁶⁷¹ Vidler, "The Building in Pain: The Body and Architecture in Post-Modern Culture." 6



Figure 241. Étienne-Jules Marey with Georges Demeny Untitled (Sprinter), after 1893

Source: "Étienne-Jules Marey with Georges Demeny," accessed July 8, 2020, <https://www.moma.org/collection/works/50087>.



Figure 242. Femme assise dans un fauteuil gris (Woman Seated in a Grey Armchair), 1939

Source: "Femme Assise Dans Un Fauteuil Gris (Woman Seated in a Grey Armchair)," accessed July 8, 2020, <https://www.museoreinasofia.es/en/collection/artwork/femme-assise-dans-fauteuil-gris-woman-seated-grey-armchair>.

The use of dismembering and remembering in ancient Egypt, in classical and modern art practices underlines the intellectual and creative nature of this process. In better terms, the reassembling of the disassembled pieces indicates an imaginative, inspiring and thought-provoking condition. Remembering, regarding its historical connotation as a learning model and the ancient practice of the “art of memory”, by relating recalling to the process of knowing, facilitates the production, storing and piercing of knowledge.

4.5.3. Display in Fragments

In terms of being a complex entity, just like the human body, architecture have been studied by pieces. Since ancient times, “the representation of architecture involved serial presentation of parts and the dissolution of a whole into constituent elements, or, conversely, the study of fragments in order to reconstitute a whole.”⁶⁷²

Especially, during the Renaissance, the increasing interest towards the establishment of proportional and compositional harmony led to the individual study and perfection of the architectural components, especially the façades, columns, column heads and entablatures. As claimed by Colomina, since Renaissance “the central reference for architecture was no longer a whole body, but a dissected, fragmented, analyzed body.”⁶⁷³ For centuries, architecture have been studied, visualized and represented, yet never been displayed in fragments till the 14th Venice Architecture Biennale.

⁶⁷² Guest, “Art, Antiquarianism and Early Anatomy.” 100

⁶⁷³ Colomina, ““Skinless Architecture.”” 123

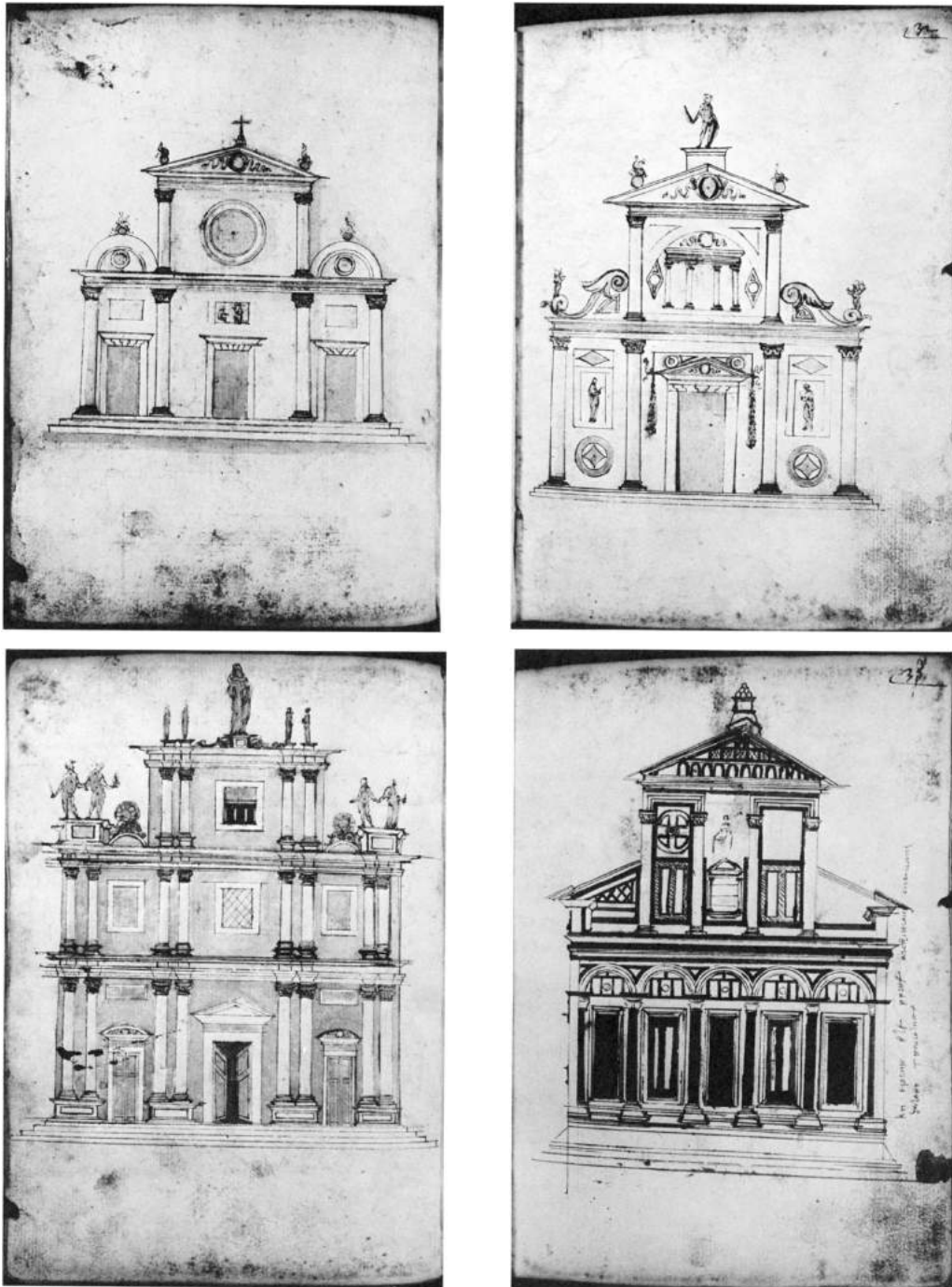

Figure 245. Façade drawings of Buonaccorso Giberti (Florence 1451-1516)

Source: Gustina Scaglia, "Three Renaissance Drawings of Church Façades," *The Art Bulletin* 47, no. 2 (1965): 173–85, 173



Figure 246. Facade of Santa Maria Novella designed by Leon Battista Alberti, constructed in 1470, Florence, photograph taken before 1922

Source: Rab Hatfield, "The Funding of the Façade of Santa Maria Novella," *Journal of the Warburg and Courtauld Institutes* 67 (2004): 81–128, 82

The 14th International Architecture Exhibition of la Biennale di Venezia (2014) entitled "Fundamentals" and curated by Rem Koolhaas, included three main exhibitions: "Absorbing Modernity 1914-2014" in National Pavilions, "Monditalia" in Arsenale and "Elements of Architecture" in Central Pavilion. The exhibition is the

result of a two-year intensive research conducted with the Harvard Graduate School of Design and a host of experts from the building industry and academia.⁶⁷⁴

Elements of Architecture focuses on the display of the fundamentals of the buildings used by any architect, in any location and time. The exhibition consists of 15 major elements of architecture: the floor, the wall, the ceiling, the roof, the door, the window, the façade, the balcony, the corridor, the fireplace, the toilet, the stair, the escalator, the elevator, the ramp.⁶⁷⁵ In the catalogue, Koolhaas describes the exhibition as:

“Previous Biennales have looked at architecture as a whole—trying to project the “full” picture, including context and politics. Here, we present micronarratives revealed by focusing systematically on the scale of the detail or the fragment. We uncover not a single, unified history of architecture, but the multiple histories, origins, contaminations, similarities, and differences of these very ancient elements and how they evolved into their current iterations through technological advances, regulatory requirements, and new digital regimes.”⁶⁷⁶

As argued by Koolhaas, the exhibition suggested a new perspective towards architectural practice and architectural history. Rather than viewing architecture as a whole, the exhibition follows a fragmentary method and analyzes the fundamental elements of architecture one by one. The grouping of the objects according to their types, enables a creative comparative study between the architectural elements that have the same function and/or their representations but belong to different time periods, places and contexts.

⁶⁷⁴ OMA, “Venice Biennale 2014: Fundamentals,” accessed July 8, 2020, <https://oma.eu/projects/venice-biennale-2014-fundamentals>.

⁶⁷⁵ Rem Koolhaas, “Elements of Architecture,” *Fundamentals Catalogue, 14th International Architecture Exhibition, La Biennale Di Venezia* (2014).193

⁶⁷⁶ Rem Koolhaas.193



Figure 247. Staircase models at the Friedrich-Mielke-Institut für Scalologie.

Source: Rem Koolhaas, "Elements of Architecture," *Fundamentals Catalogue, 14th International Architecture Exhibition, La Biennale Di Venezia* (2014).281



Figure 248. Specimens with Brain Tumors in Berlin Museum of Medical History at the Charité

Source: "Tracing Life," accessed July 8, 2020, <https://bmm-charite.de/exhibitions-neu-248/permanent-exhibition.html>.

The exhibition space was not organized chronologically or geographically, instead Koolhaas divided the exhibition space so that each subspace would correspond to a specific architectural element. In this respect, the exhibition layout of *Elements of Architecture* resembles the organization of anatomy museums, especially the ones designed with the widespread method of “regional display” where the museum space is arranged as an anatomical body. Just like the body is mapped onto the museum space in parts through regional display, the architectural elements are mapped onto the Central Pavilion.

In the exhibition space the architectural elements that belong to different time periods and geographies come together to create the idea of an abstract architectural body. In better terms, the dismembered architectural body is remembered in the *Elements of Architecture* exhibition.

The strong relationship between architecture and medicine have been discussed in detailed throughout the previous chapters. The concepts derived from medical discourse have been vastly used in the representation, theory and practice of architecture, providing significant contributions to the architectural discipline. In that sense, this thesis argues that use of the concept of “display in fragments”, which normally belongs to the field of anatomical display, has a seminal potential and could be further studied and implemented as an effective method the display of architecture.

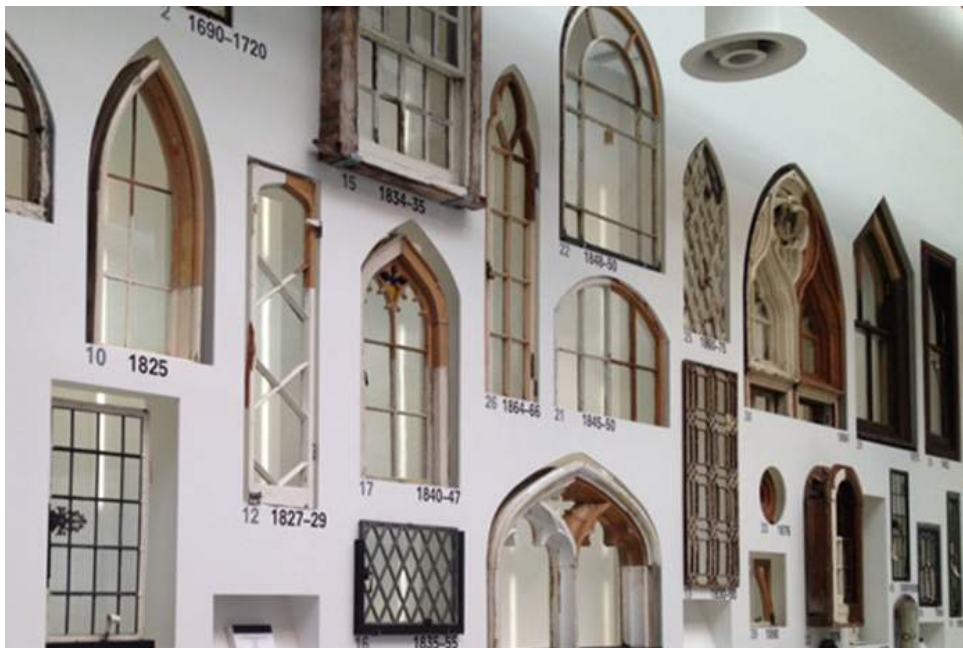

Figure 249. Photograph from the Window section in Elements of Architecture in 14th Venice Architecture Biennale, 2014, designed by Rem Koolhaas

Source: “The Elements of Architecture, Rem Koolhaas,” accessed July 8, 2020, <http://www.collectista.com/14th-venice-architecture-biennale-2014/rem-koolhaas-overview-exhibition-the-15-elements-of-architecture-venice-architecture-biennale/>.



Figure 250. Face moulage exhibit in Berlin Museum of Medical History at the Charité

Source: “Virchows Sammlung,” accessed July 8, 2020, <https://taz.de/Virchows-Sammlung/!5192854/>.

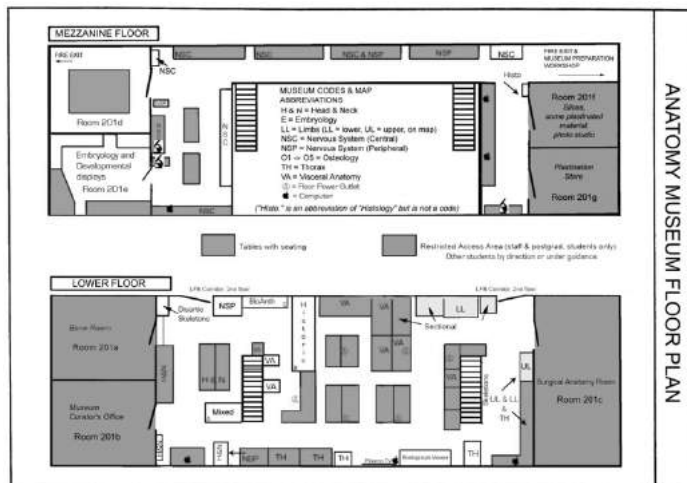

Figure 251. Layout of the W.D. Trotter Anatomy Museum at the University of Otago in New Zealand, arranged with the method of regional display

Source: Paulette Ruth McFarland Milnes, "A Pound of Flesh: Human Remains, Ethics and Museums in Tertiary Education" (Master's Thesis, Victoria University of Wellington, 2017), 56

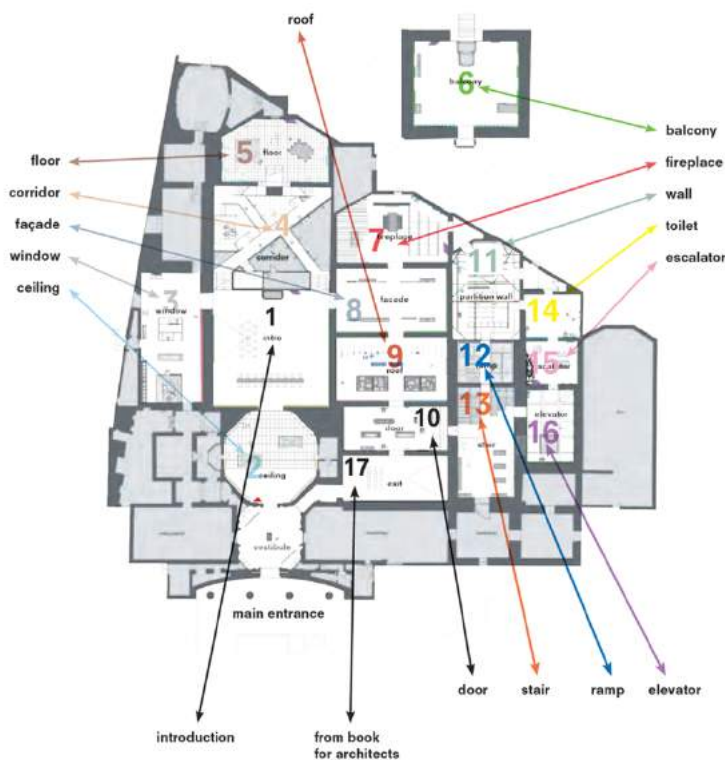

Figure 252. Elements of Architecture exhibition layout

Source: Rem Koolhaas, "Elements of Architecture," *Fundamentals Catalogue, 14th International Architecture Exhibition, La Biennale Di Venezia* (2014), 192

Ceiling

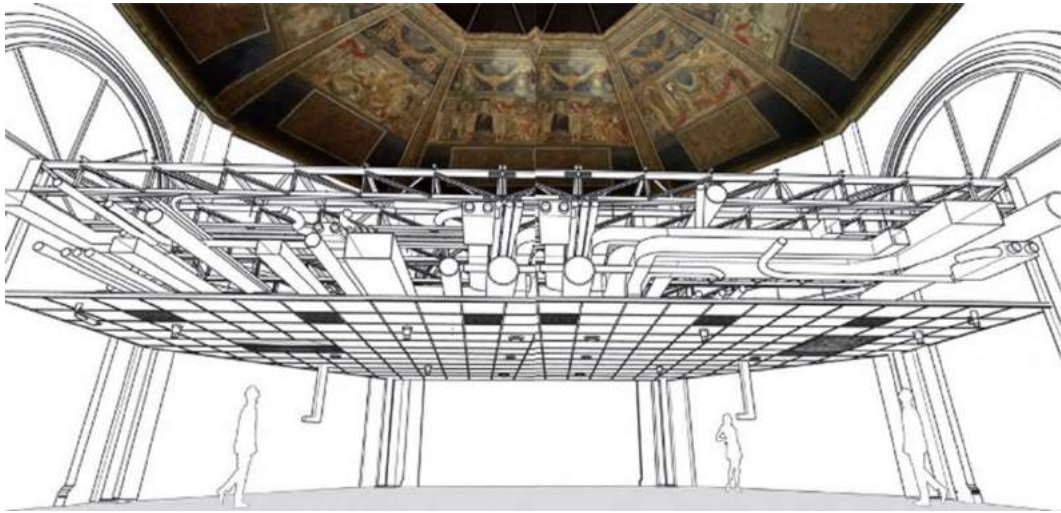

Figure 253. Ceiling section of Elements of Architecture
Source: Koolhaas, "Elements of Architecture," 208-9

Window

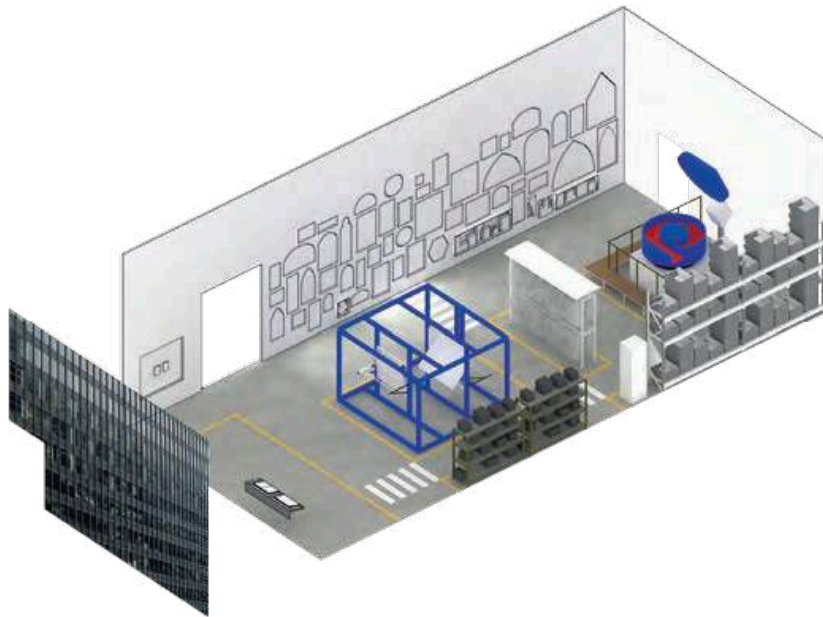

Figure 254. Window section of Elements of Architecture
Source: Koolhaas, "Elements of Architecture," 216

Corridor



Figure 255. Corridor section of Elements of Architecture

Source: Koolhaas, "Elements of Architecture," 216

Floor



Figure 256. Floor section of Elements of Architecture

Source: Koolhaas, "Elements of Architecture," 244

Balcony

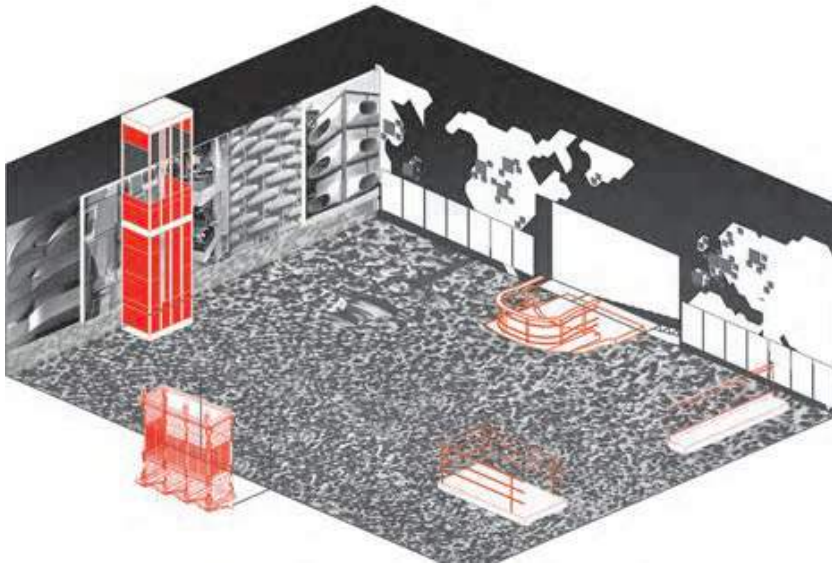

Figure 257. Balcony section of Elements of Architecture
Source: Koolhaas, "Elements of Architecture," 232

Fireplace

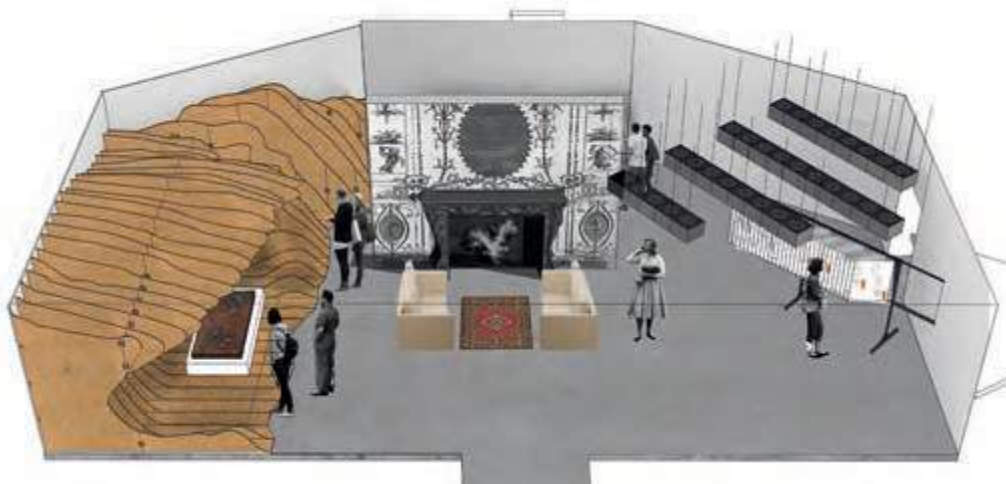

Figure 258. Fireplace section of Elements of Architecture
Source: Koolhaas, "Elements of Architecture," 238

Façade



Figure 259. Façade section of Elements of Architecture

Source: Koolhaas, "Elements of Architecture," 244

Roof



Figure 260. Roof section of Elements of Architecture

Source: Koolhaas, "Elements of Architecture," 244

Door

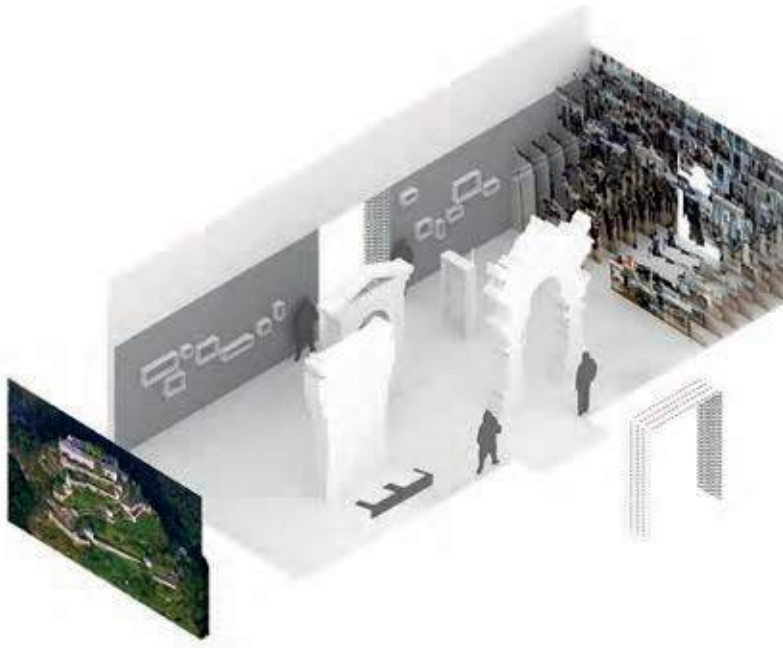

Figure 261. Door section of Elements of Architecture
Source: Koolhaas, "Elements of Architecture," 256

Wall

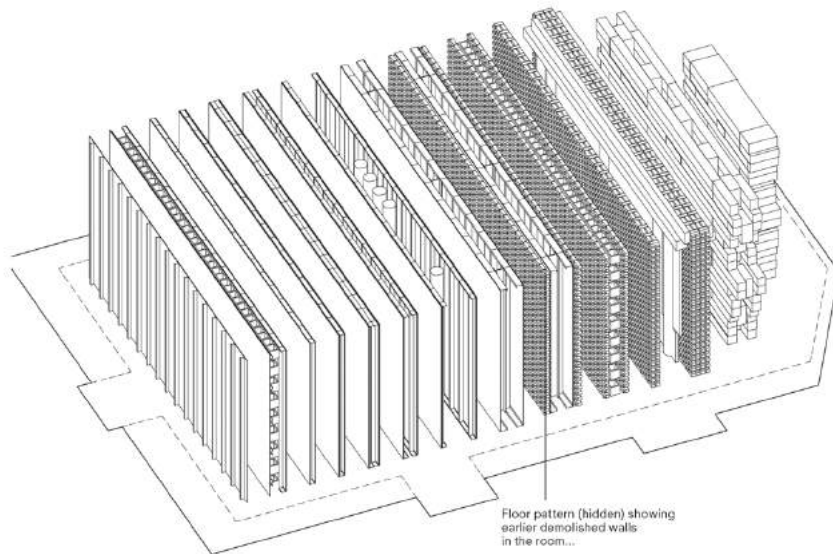

Figure 262. Wall section of Elements of Architecture
Source: Koolhaas, "Elements of Architecture," 266

Stair

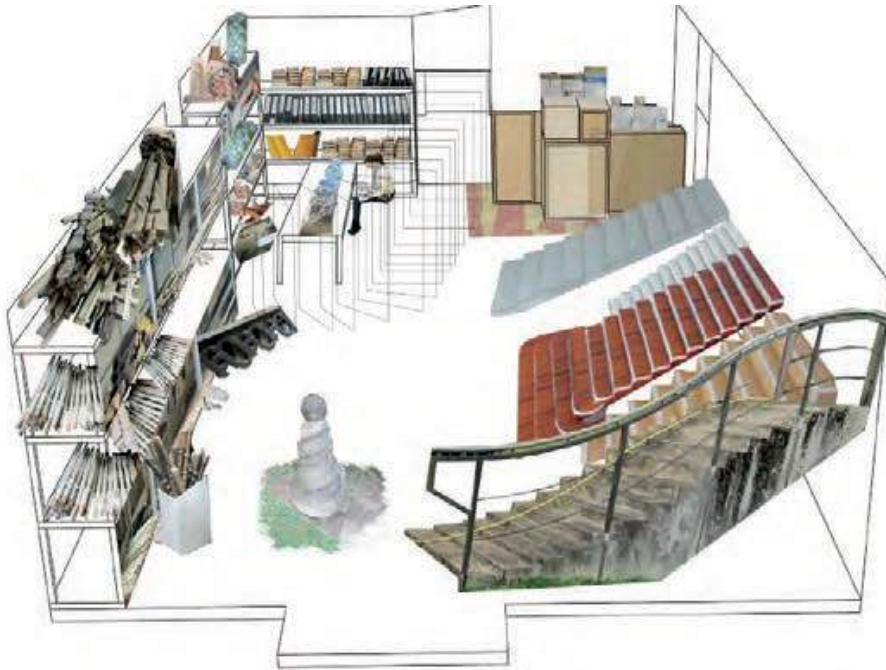

Figure 263. Stair section of Elements of Architecture

Source: Koolhaas, "Elements of Architecture," 274

Ramp



Figure 264. Ramp section of Elements of Architecture

Source: Koolhaas, "Elements of Architecture," 282

CHAPTER 5

CONCLUSION

“Architecture and medicine have always been tightly interlinked...contemporary ideas of health organize design theories today. Architectural discourse weaves itself through theories of body and brain, constructing the architect as a kind of doctor and the client as the patient.”⁶⁷⁷

Throughout the history, architecture and human body, especially from a medical/anatomical perspective, have always been in close contact, affecting, shaping and altering each other by multifarious means. Regarding the fact that, architecture is an artificial creation whereas human body is natural entity, it seems easier to recognize the impact of body on architecture compared to the influence of architecture on the body. However, the presence of countless remarkable works embodying the effects of architectural thinking on the study of human body indicates the mutual character of the association between architecture and the body. That is to say, just as the human body has been employed as a reference and source of inspiration in architectural practice and theory, body has also been studied, represented and communicated in architectural terms. Within this context, going beyond the clichéd body-based analogies in architectural discipline, this study draws attention to the reciprocity of the relations between architecture and human body and analyzes these relations varying in a wide spectrum from conceptual to practical, from a point of view that focuses on the specific concept of “anatomical display”. With the aim of providing a comprehensive understanding on this particular subject, an exhaustive research has been carried out concerning the spaces of anatomical

⁶⁷⁷ Colomina, *X-Ray Architecture*.13

display; visualization and display methods of anatomical objects; and anatomical organization of the human body.

The concept of “medical gaze” defined by Foucault plays a key role in this study. As discussed in detail previously, it is an advanced form of perceptive ability that transcends the common understanding of “seeing”. It combines the medical and visuo-spatial cognition and presents a sophisticated model of perception. By relating Foucault’s medical gaze description to the deep-seated interplay between architecture and body and claiming it as an equivalent of “architectural gaze”, this study suggests an innovative perspective.

To be able to construct seminal relationships between architecture and body within the context of anatomical display, it was necessary to carry out a profound research and critical analysis on anatomy museums – major display spaces of the anatomical body, and anatomical theatres – regarding their consideration as display spaces within the scope of this study – considering their emergence and development processes and their relation and contribution to fields of museum and theatre architecture in general. The findings gathered from this research, laid the groundwork for the selection and formation of the central themes, concepts and terms shaping the main argument of the study which are also incorporated in a comprehensive manner, considering their historical backgrounds, deep-rooted correlations, and etymological origins. The key concepts of the study could be briefly listed as: composition/harmony; space; transparency; cut and fragments. These seemingly simple, yet intrinsically complex concepts are discussed together with binary oppositions such as visible-invisible; transparency-opacity; part-whole, and interior-exterior, enhancing their polysemantic and thought-provoking quality. In addition, it is necessary to highlight that these concepts are explored in different scales and contexts that are mainly, the space of the anatomy museum; the space of the human body; and architectural and theory and practice in a broader sense.

Harmony could be regarded as the most fundamental quality underlying the association between architecture and body established upon analogical reasoning.

This way of thinking dating back to ancient Greece, refers to the consideration of natural organisms, human body in particular, as the ideal references for achieving proportional and compositional harmony in the design of architectural, artistic and technological creations. The essence of this conception has been the desire to mimic the perfect part-whole relation that is already present in the human body, in architectural design.

Another deep-seated analogy established between architectural creations and the human body is based on spatial, thus form and function oriented similarities between them. This relationship is discussed in an unconventional manner, beyond examining the inspirations driven from the anatomical organization and working mechanism of the entire body and/or the body parts in architectural design. This is done by exploring the cases where the human body has been thought and depicted as an architectural space. It is argued that, from cell to organ level, the complex spatial organization of the body bears resemblance to a well-designed architectural space. In the context of anatomy museum, the body relates to architecture in terms of forming spatial links with the display space. The process defined by the “spatialization of the body” is analyzed through the concept of “regional display” which refers to the design of the museum space as an anatomical body, in other terms the mapping of the human body onto the space of the museum.

Transparency is another profound notion that has shaped the study, discussed in relation with the mentally stimulating condition arising from the contradiction between invisible and visible, especially employed by Foucault within the context of “seeing and knowing”. The human body itself is defined as “visible invisible” with respect to its “visibility” as a physical entity and the symbol of the material world, and the “invisibility” of its complex interiors hidden underneath the seamless layer of skin comprising a sophisticated network of tissues, organs and systems and also scientific, cultural and historical knowledge embedded within. In the light of the influential study of Rowe and Slutzky, the anatomy museum is defined as a space

where the examples of both “phenomenal and literal transparency”⁶⁷⁸ could be found. The museum display is defined as a device that renders the opaque body transparent enabling it to be “known”, thus it is argued that the invisible body is made visible in the space of anatomy museum through complex conditions created by the display environment. The embodiment of the concept of transparency in architectural design and representation has been explored within the context of 20th century modern architecture, focusing on the ties between medical visualization, health and aesthetic understanding of the time based on the seminal study of Beatriz Colomina. The approach of “layering” that is closely related to the concept of transparency is analyzed in both medical and architectural frameworks.

The sophisticated nature of “medical gaze” is characterized by two major operations “cutting” and “dismembering”. As the etymology of the term itself suggests, the science of “anatomy” is basically about the act “cutting”. It is the penetration of the eye to the inner depths of the body. The bold and intense operation of cutting manifests the analytical drive to acquire the knowledge of the body. In better terms, the corporeal knowledge hidden under the skin is revealed, made visible, through the dissection performed under the medical gaze. The most apparent similarity between the architectural artifact and the human body is that both are self-enclosed three-dimensional entities with complex interior spaces. The analytical motive in both disciplines, medicine and architecture, results in the employment of “cutting” as a method of study and practice. In this framework, the powerful operation of “cutting” is explored in a broader context, comprising architectural display, representation and practice, avoiding the reduction of this analysis to the commonplace understanding of section/ section drawing in architecture.

The special organization of the human body necessitates “dismembering” in addition to “cutting” as a method of study. This is why through the centuries the process of cadaveric dissection taking place in anatomical theatres or dissection rooms in medical schools, comprises both operations. The reason behind the practice of

⁶⁷⁸ Rowe and Slutzky, “Transparency: Literal and Phenomenal.”

dismembering is the idiosyncratic organization of the human body that could be defined as a complex composition comprising numerous members where each member is a whole by itself, highly specialized, individually meaningful and almost functioning in an autonomous manner. In this context, the body has always been examined, taught and understood piece by piece, in fragments. Dismembering by itself is not sufficient for the production, acquiring and comprehension of the anatomical knowledge, thus it is accompanied with its reverse process, remembering. “Dismembering and remembering”, the highly preferred method of anatomical study, occurs at a sophisticated level in the space of anatomy museum. The dismembered body pieces on display are both physically gathered – “remembered” – in the museum space and intellectually mapped – “remembered” – in mind. The semantic duality of the term, more than being a coincidence, indicates a complex condition that underpins this study. Referring to the historical practice of “art of memory” and to the mnemonic practices in anatomy education – especially the concept of anatomical visualization – “remembering” is presented as a learning modality, a knowledge production and piercing mechanism relying on the relation between “seeing and knowing”.

Like the human body, architecture has also been studied in fragments. The method of dismembering for the study of each part in isolation, detached from its original context, providing the opportunity to understand every piece better and achieve mastery, has been employed in architectural practice, representation and research. The profound investigations on the subject reveal the fact that, although the fragment-based approach has been widely employed in anatomical display, its implementation in the display of architecture has not been common. Nevertheless, the exhibition “Elements of Architecture”, curated by Rem Koolhaas and displayed in 14th Venice Architecture Biennale could be considered as a rare example where architecture was exhibited by means of its fragments. The exhibition space was divided into sections, each devoted to a certain fundamental element of architecture and included a collection of various instances of that specific element from different geographies, cultures and time periods. It is claimed that this layout shows similarity

to “regional display” – referring to the grouping of conceptually similar “parts” of different “wholes” and the mapping of these groups onto the exhibition space – that is widely implemented in anatomy museums, therefore suggests a re-reading of Koolhaas’ exhibition. Although being a seminal concept, display in fragments is an unexplored territory for architectural discipline, thus it could be further analyzed. In that sense, the reconsideration of Elements of Architecture exhibition, within the established framework centering around the intellectually loaded concepts of “fragmentation” and “dismembering-remembering”, opens a new window into the field of “display of architecture” that would stimulate innovative ways of thinking on architecture and lay the foundation for future studies.

In terms of bridging the gap between the display of anatomy and architecture within the context of “fragments”, this thesis brings a new perspective to the deep-rooted discourse of architecture-body relationship. Regarding the similarities between human body and architectural entity, medical gaze and architectural gaze and the motives, aims, interests behind medical and architectural practices, further relations based on display could be established between architecture and medicine which would pave the way for the emergence of creative approaches that would contribute to both disciplines.

REFERENCES

- Abbott, Alison. "Hidden Treasures: Padua's Anatomy Theatre." *Nature* 454 (2008). <https://doi.org/10.1038/454699a>.
- "About Us." Accessed July 8, 2020. <https://www.guggenheim.org/about-us>.
- Ackerman, James S. *Palladio*. Harmondsworth: Penguin Books, 1966.
- Adams, Annmarie. "Encountering Maude Abbott." *Feminist Encounters: A Journal of Critical Studies in Culture and Politics* 2, no. 2 (2018): 1–17. <https://doi.org/10.20897/femenc/3889>.
- Aguirre, Peio, Nimfa Bisbe, Núria Enguita, Sergio González, Julian Heynen, and Elena Vozmediano. "The Persistence of Geometry, Exhibition Catalogue." *Contemporary Art Collections of "la Caixa" Foundation and MACBA*, 2011.
- Åhrén, Eva, and Michael Sappol. "The Strange Space of the Body: Two Dialogues." In *Strange Spaces: Explorations into Mediated Obscurity*, edited by Andre Jansson and Amanda Lagerkvist, 73–100. Farnham: Ashgate Publishing, 2009.
- Alberti, Samuel JMM. "Objects and the Museum." *Isis* 96, no. 4 (2005): 559–71.
- Alkan, Alper Semih. "Framing the 'Invisible': Section as a Spatial Frame for a Reconsideration of Architectural Representation." Master's Thesis, METU, 2004.
- "Anatomize." In *Merriam-Webster Dictionary*. Accessed July 8, 2020. <https://www.merriam-webster.com/dictionary/anatomize>.
- Anja Klöck. "Of Dissection and Technologies of Culture in Actor Training Programs – an Example from 1960s West Germany." In *Anatomy Live: Performance and the Operating Theatre*, edited by Maaïke Bleeker, 113–27. Amsterdam University Press, 2008.

Assmann, Aleida. "Body, Text, Transcendence." In *ReMembering the Body*, edited by Hortensia Völckers and Gabriele Brandstetter, 78–100. Ostfildern-Ruit: Hatje Cantz Publishers, 2000.

Assmann, Jan. "Re-Membering Osiris: From the Death Cult to Cultural Memory." In *ReMembering the Body*, edited by Hortensia Völckers and Gabriele Brandstetter, 42–78. Ostfildern-Ruit: Hatje Cantz Publishers, 2000.

Atmodiwirjo, Paramita, and Yandi Andri Yatmo. "Architecture as Machine; Towards an Architectural System for Human Well-Being." *Le Corbusier, 50 Years Later International Congress*, 2015.
<http://dx.doi.org/10.4995/LC2015.2015.679>.

Ayr, Lyna. "Disjecta Membra: A Poetic Interplay of Fragments." Master's Thesis, Auckland University of Technology, 2013.

Bakhtin, Mikhail Mikhaïlovich. *Rabelais and His World*. Cambridge: The MIT Press, 1968.

Banham, Reyner. "A Home Is Not a House." *Art in America*, no. 2 (1965).

Barthes, Roland. *The Rustle of Language*. California: University of California Press, 1986.

Bates, A.W. "'Indecent and Demoralising Representations': Public Anatomy Museums in Mid-Victorian England." *Medical History* 52, no. 1 (2008): 1–22.
<https://doi.org/10.1017/s0025727300002039>.

Bell, Charles. *Letters of Sir Charles Bell, Selected from His Correspondence with His Brother George Joseph Bell*. London: John Murray, 1870.

Berkowitz, Carin. "Systems of Display: The Making of Anatomical Knowledge in Enlightenment Britain." *The British Journal for the History of Science* 46, no. 3 (2013): 359–87. <https://www.jstor.org/stable/43820403>.

———. "The Beauty of Anatomy: Visual Displays and Surgical Education in Early-Nineteenth-Century London." *Bulletin of the History of Medicine* 85, no. 2 (2011): 248–78. <https://www.jstor.org/stable/44451985>.

- Bernheimer, Richard. "Theatrum Mundi." *The Art Bulletin* 38, no. 4 (1956): 225–47. <https://www.jstor.org/stable/3047670>.
- Blackburn, Carol. "What Is Spatial Ability?" *Imagine* 2, no. 4 (2016): 1–5. <http://web.jhu.edu/cty/STBguide.pdf>.
- Brandstetter, Gabriele. *ReMembering the Body*. Edited by Hortensia Völckers and Gabriele Brandstetter. Ostfildern-Ruit: Hatje Cantz Publishers, 2000.
- Brizio, A.M., ed. *Scritti Scelti Di Leonardo Da Vinci*. Turin, 1952.
- Broglio, Ron. "Meat Matters." In *Antennae*, edited by Giovanni Aloï, 58–71, 2010.
- Bruno, Giuliana. *Public Intimacy: Architecture and the Visual Arts*. Cambridge: The MIT Press, 2007.
- Burnham, W.H. "Memory, Historically and Experimentally Considered. I. An Historical Sketch of the Older Conceptions of Memory." *The American Journal of Psychology* 2, no. 1 (1888): 39–90. <http://www.jstor.com/stable/1411406>.
- Camp, Pannill. "Ocular Anatomy, Chiasm, and Theatre Architecture as a Material Phenomenology in Early Modern Europe." In *Anatomy Live: Performance and the Operating Theatre*, edited by Maaïke Bleeker, 129–46. Amsterdam: Amsterdam University Press, 2008.
- Campbell, Margaret. "What Tuberculosis Did for Modernism: The Influence of a Curative Environment on Modernist Design and Architecture." *Medical History* 49 (2005): 463–88. <https://doi.org/10.1017/S0025727300009169>.
- Canadelli, Elena. "'Scientific Peep Show': The Human Body in Contemporary Science Museums." *Nuncius* 26, no. 1 (2011): 159–84. <https://doi.org/10.1163/182539111X569801>.
- Chaplin, Simon. "Anatomy or Ottamy? Bodies on Show in Georgian London." In *The Morbid Anatomy Anthology*, edited by Joanna Ebenstein and Colin Dickey. New York: Morbid Anatomy Press, 2014.

- . “John Hunter and the ‘Museum Oeconomy’, 1750-1800.” PhD Thesis, King’s College London, 2009.
- . “Review: The Fate of Anatomical Collections, Edited by Rina Knoeff and Robert Zwijnenberg.” *Science Museum Group Journal*, 2016.
<https://doi.org/http://dx.doi.org/10.15180/160509>.
- Colomina, Beatriz. ““Skinless Architecture,”” 2008, 123–24.
<https://core.ac.uk/download/pdf/224742796.pdf>.
- . “The Split Wall: Domestic Voyeurism.” In *Sexuality and Space*, 73–128. New York: Princeton Architectural Press, 1992.
- . *X-Ray Architecture*. Altenburg: Lars Müller Publishers, 2019.
- Colquhoun, Alan. *Modern Architecture*. New York: Oxford University Press, 2002.
- Connerton, Paul. *How Societies Remember*. Cambridge: Cambridge University Press, 1989.
- Cooke, Thomas. “The Teaching of Anatomy: Its Aims and Methods.” *The Lancet* 142, no. 3662 (1893): 1153–55. [https://doi.org/10.1016/S0140-6736\(01\)45576-0](https://doi.org/10.1016/S0140-6736(01)45576-0).
- Corbusier, Le. *The Modulor*. Cambridge: Harvard University Press, 1966.
- . *Towards a New Architecture*. New York: Dover Publication, 1986.
- Croteau, Rene. “The Analogy of Skin in Architecture Revisited.” Master’s Thesis, Florida International University, 2006.
- Curtis, William J.R. *Modern Architecture Since 1900*. London: Phaidon Press, 1982.
- Dacome, Lucia. “Waxworks and the Performance of Anatomy in Mid-18th-Century Italy.” *Endeavour* 30, no. 1 (2006): 29–35.

Descartes, René. *Discourse on Method and the Meditations*. Penguin Books, 1968.

Dicesare, Franco. “L’Architettura Dell’Illusione a Palazzo Poggi.” University of Bologna, 2018.

Dijck, José van. “Digital Cadavers and Virtual Dissection.” In *Anatomy Live: Performance and the Operating Theatre*, edited by Maaïke Bleeker, 29–47. Amsterdam University Press, 2008.

Dijck, José Van. “Bodyworlds: The Art of Plastinated Cadavers.” *Configurations* 9, no. 1 (2001): 99–126.

Dodds, George, and Robert Tavernor. *Body and Building*. *Body and Building*, 2002. <https://doi.org/10.7551/mitpress/1637.001.0001>.

Ekman, Mattias. “Spatial Orders of Memory and Knowledge: Architectural Schemes for Collections in Seventeenth-Century Sweden.” *Nordisk Museologi* 1 (2016): 148–58.

Eknoyan, Garabed. “Michelangelo: Art, Anatomy, and the Kidney.” *Kidney International* 57 (2000): 1190–1201.

Elkins, James. “Cut Flesh.” In *Pictures of the Body: Pain and Metamorphosis*. Redwood City: Stanford University Press, 1999.

“Embodiment.” In *Merriam-Webster Dictionary*. Accessed July 8, 2020. <https://www.merriam-webster.com/dictionary/embodiment>.

Farago, Jason. “Why Museums Are the New Churches,” 2015. <http://www.bbc.com/culture/story/20150716-why-museums-are-the-new-churches>.

Ferrari, Giovanna. “Public Anatomy Lessons and the Carnival: The Anatomy Theatre of Bologna.” *The Past and Present Society*, no. 117 (1987): 50–106. <http://www.jstor.org/stable/650788>.

Ferreira, M. Piedade, Duarte Cabral de Mello, and José Pinto Duarte. “The

Grammar of Movement: A Step Towards a Corporeal Architecture.” *Nexus Network Journal* 13, no. 1 (2011): 131–49.

Ferreira, Maria da Piedade Aldinhas de Freitas. “Embodied Emotions: Observations and Experiments in Architecture and Corporeality.” PhD Thesis, University of Lisbon, 2015.

Flower, W.H. “Note on the Construction and Arrangement of Anatomical Museums.” *Journal of Anatomy and Physiology* 9, no. Pt 2 (1875): 259–62.

Forgan, Sophie. “Building the Museum Knowledge, Conflict, and the Power of Place.” *Isis* 96, no. 4 (2005): 572–85.
<http://www.jstor.org/stable/10.1086/498594>.

Foucault, Michel. “Of Other Spaces: Utopias and Heterotopias.” *Diacritics* 16, no. 1 (1986): 22–27. <https://www.jstor.org/stable/464648>.

———. *The Birth of the Clinic: An Archaeology of Medical Perception*. London: Routledge, 2003.

———. *The Order of Things: An Archeology of the Human Sciences*. London: Routledge, 2005.

Frascardi, Marco. “A Tradition of Architectural Figures: A Search for Vita Beata.” In *Body and Building: Essays on the Changing Relation of Body and Architecture*, edited by George Dodds and Robert Tavernor, 258–67. Cambridge: The MIT Press, 2002.

“Future of the Medical Museum.” *The Lancet* 245, no. 6343 (1945): 376–77.
[https://doi.org/10.1016/S0140-6736\(45\)90225-X](https://doi.org/10.1016/S0140-6736(45)90225-X).

Gaskell, Ivan. “University and College Museums: Some Challenges.” *The Antioch Review* 74, no. 2 (2016): 228–36.

Gillette, Arthur. “Museum Architecture: Beyond the ‘Temple’ and... Beyond.” *Museum International* 41, no. 4 (1989): 247–56.

- “Gordon Matta-Clark Conical Intersect.” Accessed July 8, 2020.
<https://www.guggenheim.org/artwork/5211>.
- Gruber, P., and S. Gosztonyi. “Skin in Architecture: Towards Bioinspired Facades.” *WIT Transactions on Ecology and the Environment* 138 (2010): 503–13. <https://doi.org/10.2495/DN100451>.
- Guattari, Felix. “On Machines.” *Journal of Philosophy and the Visual Arts* 6, no. 8 (1995): 8–12.
- Guest, Clare E. L. “Art, Antiquarianism and Early Anatomy.” *Medical Humanities* 40, no. 2 (2014): 97–104. <http://dx.doi.org/10.1136/medhum-2013-010419>.
- Haddad, Naif, and Talal Akasheh. “Vitruvius and Ancient Theatres.” In *ERATO Project Symposium Proceedings*, 2006.
- Hallam, Elizabeth. *Anatomy Museum: Death and the Body Displayed*. London: Reaktion Books, 2016.
- Hallam, Elizabeth, and Samuel JMM Alberti. “Bodies in Museums.” In *Medical Museums: Past, Present, Future*, edited by Samuel JMM Alberti and Elizabeth Hallam, 1–15. London: The Royal College of Surgeons of England, 2013.
- Hartley, J.N.J. “The Early History of the Museum of the Royal College of Surgeons of Edinburgh.” *Edinburgh Medical Journal* 55, no. 9 (1948): 513–32.
- Haupt, Paul. “The Etymology of Cabinet.” *Journal of the American Oriental Society* 28 (1907): 108–11. <https://www.jstor.org/stable/592762>.
- Havlíková, Alena. “Adolf Loos.” Accessed July 8, 2020.
<https://adolfloos.cz/en/adolf-loos>.
- Heidegger, Martin. “The Age of the World View.” *Boundary 2* 4, no. 2 (2019): 340–55. <https://www.jstor.org/stable/302139>.

Hendriksen, Merieke, Hieke Huistra, and Rina Knoeff. "Recycling Anatomical Preparations: Leiden's Anatomical Collections." In *Medical Museums: Past, Present, Future*, edited by Samuel JMM Alberti and Elizabeth Hallam, 74–87. London: The Royal College of Surgeons of England, 2013.

Henry, Chris. "Museums Within a Museum." In *Medical Museums: Past, Present, Future*, edited by Samuel JMM Alberti and Elizabeth Hallam, 30–43. London: The Royal College of Surgeons of England, 2013.

Hesiod. *Theogony Works and Days Testimonia*. Edited by Glenn W. Most. *Harvard University Press*. London: Harvard University Press, 2006.

Hill, C.R. "The Cabinet of Bonnier de La Mosson (1702–1744)." *Annals of Science* 43, no. 2 (1986): 147–74. <https://doi.org/10.1080/00033798600200191>.

"History and Vision." Accessed December 11, 2019. <https://www.rcsed.ac.uk/the-college/about-us/history-and-vision>.

"History of Ashmolean." Accessed July 8, 2020. <https://www.ashmolean.org/history-ashmolean>.

"History of the College Museums." Accessed October 7, 2020. <https://www.rcseng.ac.uk/museums-and-archives/hunterian-museum/about-us/history/>.

Hooper-Greenhill, Eilean. *Museums and the Shaping of Knowledge*. London: Routledge, 1992.

Huisman, Tim. "The Finger of God: Anatomical Practice in 17th-Century Leiden." PhD Thesis, Leiden University, 2009.

Hunter, Michael. *The Cabinet Institutionalized: The Royal Society's "Repository" and Its Background*, 1985.

Hussey, Kristin D. "Seen and Unseen: The Representation of Visible and Hidden Disease in the Waxworks of Joseph Towne at the Gordon Museum." *19: Interdisciplinary Studies in the Long Nineteenth Century*, no. 24 (2017): 1–10. <https://doi.org/10.16995/ntn.787>.

- Infante-Guell, Manuela. "Performance Documentation 8: Körper." In *Anatomy Live: Performance and the Operating Theatre*, 245–49. Amsterdam University Press, 2008.
- Ingham, Karen. "The Anatomy Lesson of Professor Moxham." In *Anatomy Live: Performance and the Operating Theatre*, edited by Maaïke Bleeker, 75–91. Amsterdam University Press, 2008.
- Ioannidou, Ersi. "Humanist Machines: Daniel Libeskind's 'Three Lessons in Architecture.'" In *The Humanities in Architectural Design A Contemporary and Historical Perspective*, edited by Soumyen Bandyopadhyay, Jane Lomholt, Nicholas Temple, and Renée Tobe. Abingdon: Routledge, 2010.
- Jacobs, Fredrika. "(Dis)Assembling: Marsyas, Michelangelo, and the Accademia Del Disegno." *The Art Bulletin* 84, no. 3 (2002): 426–48.
<http://www.jstor.org/stable/3177307>.
- Jenkins, Bruce. *Gordon Matta-Clark: Conical Intersect*. London: Afterall Books, 2011.
- John Berger. *Ways of Seeing*. London: Penguin Books, 2008.
- Joseba Zulaika. *Guggenheim Bilbao Museoa Museums, Architecture, and City Renewal*. Reno: Center for Basque Studies University of Nevada, 2003.
- Kahn, Louis. "Architecture Is the Thoughtful Making of Spaces." *Perspecta* 4 (1957): 2–3. <https://www.jstor.org/stable/1566850>.
- Kemp, Dawn, and Sarah Barnes. *Surgeons' Hall: A Museum Anthology*. Edinburgh: Royal College of Surgeons, 2009.
- Kemp, Martin, and Marina Wallace. *Spectacular Bodies: The Art and Science of the Human Body From Leonardo to Now*. London: Hayward Gallery Publishing, 2000.
- Kepes, Gyorgy. *Language of Vision*. New York: Dover Publications, 1995.

- Kepler, Johannes, and William H. Donahue (trans.). *Optics: Paralipomena to Witelo & Optical Part of Astronomy*. Santa Fe: Green Lion Press, 2000.
- Kleinschmidt, Harry Edwin. "New Germany Teaches Her People. An Account of the Health Exposition of Berlin." *American Journal of Public Health and the Nation's Health* 25, no. 10 (1935): 1108–13.
- Knox, Frederick John. *The Anatomist's Instructor, and Museum Companion: Being Practical Directions for the Formation and Subsequent Management of Anatomical Museums*. Edinburgh: Adam and Charles Black, 1836.
- Kuhn, Thomas S. *The Structure of Scientific Revolutions*. Chicago: University of Chicago Press, 1962.
- Kuppers, Petra. "Visions of Anatomy: Exhibitions and Dense Bodies." *Differences* 15, no. 3 (2004): 123–56. <https://doi.org/10.1215/10407391-15-3-123>.
- Lab, Jenny Sabin. "ESkin." Accessed July 8, 2020. sabinlab.com/eskin.
- Larsson, Matz. "The Optic Chiasm: A Turning Point in the Evolution of Eye/Hand Coordinatin." *Frontiers in Zoology* 10, no. 1 (2013): 1–12.
- Leder, Drew. *Absent Body*. University of Chicago Press, 1990.
- Lee, Pamela M. "On the Holes of History : Gordon Matta-Clark's Work in Paris." *October* 85 (1998): 65–89. <http://www.jstor.com/stable/779183>.
- Lewis, Charlton T., and Charles Short. *A Latin Dictionary*. Oxford: Clarendon Press, 1879.
- Lin, Zhongjie. "Nakagin Capsule Tower Revisiting the Future of the Recent Past." *Journal of Architectural Education* 65, no. 1 (2011): 13–32. <http://www.jstor.com/stable/41319216>.
- Logan Clendening. *The Human Body*. New York and London: Alfred A. Knopf, 1928.

- Lynch, Michael. "The Production of Scientific Images: Vision and Re-Vision in the History, Philosophy and Sociology of Science." In *Visual Cultures of Science: Rethinking Representational Practices in Knowledge Building and Science Communication*, edited by Luc Pauwels, 26–40. Hannover: Dartmouth College Press, 2006.
- Maaikje Bleeker, ed. *Anatomy Live: Performance and the Operating Theatre*. Amsterdam: Amsterdam University Press, 2008.
- MacGregor, Arthur, and O. R. Impey, eds. *The Origins of Museums: The Cabinet of Curiosities in Sixteenth and Seventeenth-Century Europe*. Oxford: Clarendon Press, 1985.
- Macleod, Suzanne, Laura Hourston Hanks, and Jonathan Hale, eds. *Museum Making: Narratives, Architectures, Exhibitions*. New York: Routledge, 2012.
- Maraldi, Nadir M., Giovanni Mazzotti, Lucio Cocco, and Francesco A. Manzoli. "Anatomical Waxwork Modeling: The History of the Bologna Anatomy Museum." *The Anatomical Record* 261, no. 1 (2000): 5–10.
- "Marischal College." Accessed July 8, 2020.
<https://www.abdn.ac.uk/about/campus/marischal-college-394.php>.
- Markus, Thomas A. "Domes of Enlightenment: Two Scottish University Museums." *Museum Management and Curatorship* 4, no. 3 (1985): 215–42.
- Matteo, Berardo Di, Vittorio Tarabella, Giuseppe Filardo, Anna Viganò, Patrizia Tomba, Laura Bragonzoni, and Maurilio Marcacci. "Art In Science: The Stage of the Human Body—The Anatomical Theatre of Bologna." *Clinical Orthopaedics and Related Research* 473, no. 6 (2015): 1873–78.
<https://doi.org/10.1007/s11999-015-4288-8>.
- Mavrodi, Alexandra, and George Paraskevas. "Mondino de Luzzi: A Luminous Figure in the Darkness of the Middle Ages." *Croatian Medical Journal* 55, no. 1 (2014).
- Maxwell, Ian. "'Who Were You?' : The Visible and the Visceral." In *Anatomy Live: Performance and the Operating Theatre*, edited by Maaikje Bleeker, 49–66. Amsterdam University Press, 2008.

- Mescher, Anthony L. *Junqueras's Basic Histology Text and Atlas*. 14th ed. McGraw-Hill Education, 2016.
- Messbarger, Rebecca. "The Re-Birth of Venus in Florence's Royal Museum of Physics and Natural History." *Journal of the History of Collections* 25, no. 2 (2012): 1–21. <https://doi.org/10.1093/jhc/fhs007>.
- "Mind's Eye." In *Merriam-Webster Dictionary*. Accessed July 8, 2020. [https://www.merriam-webster.com/dictionary/mind%27s eye](https://www.merriam-webster.com/dictionary/mind%27s%20eye).
- Moeschl, Peter. "Images of the Body: On Sensory Perception in Medicine and in Everyday Life." In *ReMembering the Body*, edited by Hortensia Völckers and Gabriele Brandstetter, 286–300. Ostfildern-Ruit: Hatje Cantz Publishers, 2000.
- Monza, Francesca, and Silvia Iorio. "Bodies for Science. The Display of Human Statues for Educational Purposes." *Medicina Historica* 2, no. 3 (2018): 145–51.
- Moore, Rosemary. "Paper Cuts: The Early Modern Fugitive Print." *Object* 17, no. 1 (2015): 54–76.
- Moore, Rowan. "The Bilbao Effect: How Frank Gehry's Guggenheim Started a Global Craze." *The Guardian*, October 1, 2017. <https://www.theguardian.com/artanddesign/2017/oct/01/bilbao-effect-frank-gehry-guggenheim-global-craze>.
- Mumford, Lewis. "What Wright Hath Wrought." *The New Yorker*, 1959. <https://www.newyorker.com/magazine/1959/12/05/what-wright-hath-wrought>.
- Murray, David. *Museums, Their History and Their Use*. Glasgow: James MacLehose and Sons, 1904.
- Nesbitt, Kate, ed. *Theorizing a New Agenda for Architecture: An Anthology of Architectural Theory 1965-1995*. New York: Princeton Architectural Press, 1996.
- Nesi, Gabriella, Raffaella Santi, and Gian Luigi Taddei. "Art and the Teaching of

Pathological Anatomy at the University of Florence since the Nineteenth Century.” *Virchows Archiv* 455, no. 1 (2009): 15–19.
<https://doi.org/10.1007/s00428-009-0794-y>.

Nicholson, Ben. *Appliance House*. Chicago Institute for Architecture and Urbanism, 1990.

Obrist, Hans Ulrich, Vivian Rehberg, and Stefano Boeri. “Moving Interventions: Curating at Large.” *Journal of Visual Culture* 2, no. 2 (2003): 147–60.
<https://doi.org/10.1177/14704129030022001>.

OMA. “Venice Biennale 2014: Fundamentals.” Accessed July 8, 2020.
<https://oma.eu/projects/venice-biennale-2014-fundamentals>.

Onians, John. “Greek Temple and Greek Brain.” In *Body and Building: Essays on the Changing Relation of Body and Architecture*, edited by George Dodds and Robert Tavernor, 44–63. Cambridge: The MIT Press, 2002.

Papa, Veronica, Elena Varotto, Mauro Vaccarezza, Roberta Ballestriero, Domenico Tafuri, and Francesco M. Galassi. “The Teaching of Anatomy Throughout the Centuries: From Herophilus to Plastination and Beyond.” *Medicina Historica* 3, no. 2 (2019): 69–77.

“Part V-Animating Bodies, Exhibition Gallery Guide.” *Paper Worlds: Printing Knowledge in Early Modern Europe*. Harvard University, 2010.

Patten, Debra. “What Lies Beneath: The Use of Three-Dimensional Projection in Living Anatomy Teaching.” *The Clinical Teacher* 4, no. 1 (2007): 10–14.
<https://doi.org/10.1111/j.1743-498X.2007.00136.x>.

Peter Lloyd Jones. “Minding the Gap: Caring for Collaboration between Art & Science by Design.” *Sciart Magazine*, 2018, 1–15.

Pohl, Ethel Baraona. “BIX Light and Media Façade at MoMA.” ArchDaily. Accessed July 8, 2020. <https://www.archdaily.com/89408/bix-light-and-media-facade-at-moma>.

Prentice, Rachel. *Bodies in Formation: An Ethnography of Anatomy and Surgery*

- Education*. Durham: Duke University Press, 2013.
- Rault, Jasmine. *Eileen Gray and the Design of Sapphic Modernity: Staying In*. Surrey: Ashgate Publishing, 2011.
- Reinarz, Jonathan. "The Age of Museum Medicine: The Rise and Fall of the Medical Museum at Birmingham's School of Medicine." *Social History of Medicine* 18, no. 3 (2005): 419–37. <https://doi.org/10.1093/shm/hki050>.
- Rem Koolhaas. "Elements of Architecture." *Fundamentals Catalogue, 14th International Architecture Exhibition, La Biennale Di Venezia*, 2014.
- Rindel, Jens Holger. "Roman Theatres and Revival of Their Acoustics in the ERATO Project." *Acta Acustica United with Acustica* 99, no. 1 (2013): 21–29. <https://doi.org/10.3813/AAA.918584>.
- Robertson, Donald Struan. *Greek and Roman Architecture*. Cambridge: Cambridge University Press, 1969.
- Robin Pogrebin. "British Architect Wins 2007 Pritzker Prize." *The New York Times*, March 2007. <https://www.nytimes.com/2007/03/28/arts/design/28cnd-pritzker.html?hp>.
- Rowe, Colin, and Robert Slutzky. "Transparency: Literal and Phenomenal." *Perspecta* 8 (1963): 45–54. <http://www.jstor.org/stable/1566901>.
- Rozhkovskaya, Natasha. "Mathematical Commentary on Le Corbusier's Modulor." *Nexus Network Journal* 22, no. 2 (2020): 411–28.
- Sabin, Jenny E., and Peter Lloyd Jones. "Sabin + Jones LabStudio : Nonlinear Systems Biology and Design." *AIA Report on University Research* 5 (2008).
- Sappol, Michael. *Dream Anatomy*. Bethesda MD and Washington DC: US Dept. of Health and Human Services, National Institutes of Health, National Library of Medicine, 2006.
- Satsia, Marisa. "Inner Space: The Evolution of the Representation of the Human

- Body in Art and Science.” Bachelor Thesis, The University of Dundee, 2014.
- Schittich, Christian, ed. *In Detail: Building Skins*. Basel: Birkhäuser, 2001.
- Schroeder-Gudehus, Brigitte. “Patrons and Publics: Museums as Historical Artefacts.” *History and Technology, an International Journal* 10, no. 1 (1993): 1–3.
- Schumacher, Gert Horst. “Theatrum Anatomicum in History and Today.” *International Journal of Morphology* 25, no. 1 (2007): 15–32. <https://doi.org/10.4067/S0717-95022007000100002>.
- Sear, Frank B. “Vitruvius and Roman Theatre Design.” *American Journal of Archaeology* 94, no. 2 (1990): 249–58. <http://www.jstor.org/stable/505952>.
- Simmons, Alison. “Spatial Perception from a Cartesian Point of View.” *Philosophical Topics* 31, no. 1/2 (2003): 395–423.
- “Spatialization.” In *Collins Dictionary*. Accessed July 8, 2020. <https://www.collinsdictionary.com/dictionary/english/spatialization>.
- Steadman, Philip. *The Evolution of Designs: Biological Analogy in Architecture and the Applied Arts*. New York: Routledge, 2008.
- Stephens, Elizabeth. “Inventing the Bodily Interior: Écorché Figures in Early Modern Anatomy and von Hagens’ Body Worlds.” *Social Semiotics* 17, no. 3 (2007): 313–26. <http://dx.doi.org/10.1080/10350330701448611>.
- “The Extraordinary General Conference Postpones the Vote on a New Museum Definition,” 2019. <https://icom.museum/en/news/the-extraordinary-general-conference-pospones-the-vote-on-a-new-museum-definition/>.
- “The Pritzker Architecture Prize.” Accessed July 8, 2020. <https://www.pritzkerprize.com/jury-citation-richard-rogers>.
- Thomas, Nigel J.T. “Mental Imagery.” Accessed July 8, 2020. <https://plato.stanford.edu/entries/mental-imagery/>.

- Thomas Schnalke. "Tracing Life: The Berlin Museum of Medical History at the Charité." In *Medical Museums: Past, Present, Future*, edited by Samuel JMM Alberti and Elizabeth Hallam, 130–43. London: The Royal College of Surgeons of England, 2013.
- Thompson, John, Jo Ann Kuchera-Morin, Marcos Novak, Dan Overholt, Lance Putnam, Graham Wakefield, and Wesley Smith. "The Allobrain: An Interactive, Stereographic, 3D Audio, Immersive Virtual World." In *CHI Conference Workshop on Sonic Interaction Design*, 2008.
- Trelease, Robert B. "Anatomy Meets Architecture: Designing New Laboratories for New Anatomists." *Anatomical Record - Part B New Anatomist* 289, no. 6 (2006): 241–51. <https://doi.org/10.1002/ar.b.20118>.
- Vesely, Dalibor. "The Architectonics of Embodiment." In *Body and Building: Essays on the Changing Relation of Body and Architecture*, edited by George Dodds and Robert Tavernor, 28–43. Cambridge: The MIT Press, 2002.
- Vidler, Anthony. "The Building in Pain: The Body and Architecture in Post-Modern Culture." *AA Files*, no. 19 (1990): 3–10. <https://www.jstor.org/stable/29543679>.
- Vitruvius. *Ten Books on Architecture*. Cambridge: Harvard University Press, 1914.
- Warren, William H. "Constructing an Econiche." In *Global Perspectives on the Ecology of Human-Machine Systems*, edited by John M. Flach, Peter A. Hancock, Jeff Caird, and Kim J. Vicente, 210–37. Boca Raton: CRC Press, 2018.
- Wilson, Luke. "William Harvey's Prelectiones: The Performance of the Body in the Renaissance Theater of Anatomy." *Representations*, no. 17 (2018): 62–95.
- Wittkower, Rudolf. *Architectural Principles in the Age of Humanism*. London: Wiley, 1962.
- "Wonders of the Human Body Reproduced in Museum by Machines and Electricity." *Popular Science Monthly* 127 (1935): 36–37.

Yates, Frances Amelia. *Giordano Bruno and the Hermetic Tradition*. Chicago: University of Chicago Press, 1964.

———. *The Art of the Memory*. New York: Routledge, 1966.

Žižek, Slavoj. *The Metastases of Enjoyment: Six Essays on Women and Causality*. London: Verso, 2005.