

DAY AHEAD MARKETS

A THESIS SUBMITTED TO
THE GRADUATE SCHOOL OF NATURAL AND APPLIED SCIENCES
OF
MIDDLE EAST TECHNICAL UNIVERSITY

BY

KAAN KÜTARUK

IN PARTIAL FULFILLMENT OF THE REQUIREMENTS
FOR
THE DEGREE OF MASTER OF SCIENCE
IN
ELECTRICAL AND ELECTRONICS ENGINEERING

SEPTEMBER 2013

Approval of the thesis:

DAY AHEAD MARKETS

submitted by **KAAN KÜTARUK** in partial fulfillment of the requirements for the degree of **Master of Science in Electrical and Electronics Engineering Department, Middle East Technical University** by,

Prof. Dr. Canan Özgen

Dean, Graduate School of **Natural and Applied Sciences**

Prof. Dr. Gönül Turhan Sayan

Head of Department, **Electrical and Electronics Engineering**

Prof. Dr. Osman Sevaioğlu

Supervisor, **Electrical and Electronics Engineering Dept., METU**

Examining Committee Members:

Prof. Dr. Mirzahan Hızal

Electrical and Electronics Engineering Dept., METU

Prof. Dr. Osman Sevaioğlu

Electrical and Electronics Engineering Dept., METU

Prof. Dr. İsmet Erkmen

Electrical and Electronics Engineering Dept., METU

Prof. Dr. Cengiz Taplamacıoğlu

Vice Rector, UTAA

M.Sc. Abdülkadir Ongun

Security of Supply Dept., MENR

Date: 16.09.2013

I hereby declare that all information in this document has been obtained and presented in accordance with academic rules and ethical conduct. I also declare that, as required by these rules and conduct, I have fully cited and referenced all material and results that are not original to this work.

Name, Last name : Kaan KÜTARUK

Signature :

ABSTRACT

DAY AHEAD MARKETS

Kütaruk, Kaan

M. Sc., Department of Electrical and Electronics Engineering

Supervisor: Prof. Dr. Osman Sevaioğlu

September 2013, 199 pages

Day Ahead Market is a mechanism in electricity markets for adjusting the supply-demand energy and capacity balance by providing bids one day before the clearing.

Market operator needs to know the available energy and capacity for reaching minimal-cost supply-demand balance one day earlier than the market has been cleared. Minimizing cost of the electricity and capacity during 24 hours of a day requires accurate information concerning the available electricity and capacity.

Day-ahead marketing activity is performed so as to reach financial certainty which can remove the risk of incurring high operational and startup prices. For Day Ahead marketing, the trading activity has to be performed one day earlier for the delivery of electricity the next day.

Bilateral markets, exchanges and pools are the architectures which employ the Day Ahead Market Model. Each of these architectures or combination can provide financial hedging and unit commitment. The most suitable architecture is chosen by concerns over lack of private markets and nonprofit system operators in performing the coordination functions related with unit commitment. Thus, some theories of market try to explain the structure for evaluating the combinations of different designs.

The study will include the development of a mathematical model for Day Ahead Market Architecture and a computer program that will simulate the developed model on the Turkish Electricity Market.

Keywords: Day Ahead Market, Market Operator, Supply Demand Balance, Bilateral Markets

ÖZ

GÜN ÖNCESİ PİYASALARI

Kütaruk, Kaan

Yüksek Lisans, Elektrik ve Elektronik Mühendisliği Bölümü

Tez Yöneticisi: Prof. Dr. Osman Sevaioğlu

Eylül 2013, 199 sayfa

Gün Öncesi Piyasası, elektrik piyasalarında arz-talep ve kapasite enerji dengesini sağlamak için enerji transferi tekliflerinin ve ticaretinin bir gün öncesinden yapıldığı bir sistemdir.

Piyasa operatörünün en düşük maliyetli arz talep dengesini enerji transferinden bir gün önce yapılabilmesi için kullanılabilir enerji ve kapasiteyi bilmesi gereklidir. 24 saat önceden en düşük maliyetli elektrik ve kapasiteyi elde edebilmek için kullanılabilir elektrik ve kapasitenin doğru olarak bilinmesi gereklidir.

Gün Öncesi Piyasasının amacı finansal kararlılığı sağlayarak yüksek çalışma ve başlangıç fiyatlarını engellemektir. Gün Öncesi Piyasası'nda elektrik ticareti, elektrik transferinden bir gün önce gerçekleştirilir.

İkili anlaşmalar, değişimler ve havuz Gün Öncesi Piyasası'nda yer alan piyasa mimarileridir. Bu modellerden her biri veya birkaçının birleşimi sayesinde ekonomik korunma ve taahhütler gerçekleştirilmiş olur. En uygun piyasa modeli kar amacı gütmeyen sistem operatörü tarafından seçilir ve koordine edilir. Bu yüzden birçok piyasa teorisi çeşitli piyasa modeli birleşimlerinin yapısını değerlendirmeye çalışır.

Bu çalışmada Gün Öncesi Piyasalarının mimarileri matematiksel olarak çalışılacak ve bilgisayar programı aracılığı ile Türkiye'de uygulanan elektrik marketi modellenecektir.

Anahtar Kelimeler: Gün Öncesi Piyasası, Piyasa Operatörü, Arz Talep Dengesi, İkili Anlaşmalar

To My Family, with love and gratitude

ACKNOWLEDGEMENTS

I would like to express my sincere thanks and gratitude to my supervisor Prof. Dr. Osman Sevaioğlu for his complete guidance, advice and criticism throughout this thesis.

I am also thankful to all lecturers at the Department of Electrical and Electronics Engineering, who helped me to acquire the basic knowledge onto which I have built my thesis.

I would like to express my appreciation to ASELSAN Inc. for providing me a peaceful working environment and my colleagues in ASELSAN Inc. for their support.

I also would like to thank Mr. Abdülkadir Ongun for his valuable ideas and help throughout this study.

Finally, I would like to express my special thanks to my family for their permanent support and sincere love.

TABLE OF CONTENTS

ABSTRACT.....	iii
ÖZ.....	v
ACKNOWLEDGMENTS.....	vii
TABLE OF CONTENTS.....	viii
LIST OF TABLES.....	xi
LIST OF FIGURES.....	xii

CHAPTERS

1	INTRODUCTION.....	1
2	GENERAL OVERVIEW OF THE ELECTRICITY MARKET STRUCTURES.....	3
2.1	Introduction.....	3
2.2	Single Seller Model.....	5
2.3	Single Buyer Model.....	7
2.4	Multiple Seller Multiple Buyer Model.....	9
2.4.1	Pool Model.....	10
2.4.2	Bilateral Contract Model.....	12
2.4.3	Balancing and Settlement Problem of Bilateral Contract.....	
	Model.....	14
2.4.3.1	Day Ahead Markets.....	15
2.4.3.2	Real Time Markets.....	15
3	COST MODELLING, MARGINAL COST, SHORT TERM DEMAND FORECAST.....	17
3.1	Cost Modeling.....	17
3.1.1	Data Sources.....	18
3.1.1.1	Timing.....	18
3.1.1.2	Technical Data.....	19
3.1.1.3	Capital Costs.....	19
3.1.1.4	Operating Costs.....	20

3.1.2	Cost Curves.....	20
3.1.2.1	Short Run.....	21
3.1.2.2	Long Run.....	22
3.1.2.2.1	Short Run - Long Run Cost Relationship.....	23
3.2	Marginal Cost.....	24
3.2.1	Marginal Cost and Average Cost Relationship.....	28
3.3	Short Term Load Forecasting.....	29
3.3.1	Factors Affecting Short Term Load Forecasting	30
3.3.2	Artificial Neural Network.....	31
4	DAY AHEAD MARKETS AND MODELS.....	37
4.1	Structure of Day Ahead Markets.....	37
4.1	38	
4.2	Aim of Day Ahead Markets	38
4.3	Sides of Day Ahead Markets.....	41
4.4	Supply-Demand Balance.....	43
4.5	Models of Day Ahead Markets in the World	48
4.5.1	Auction Trading.....	48
4.5.1.1	Uniform Price Model (Market Clearing Price)...	49
4.5.1.2	Pay As Bid.....	50
4.5.1.3	Comparison between Uniform Price Auction vs. Pay As Bid Auction.....	51
4.5.2	Continuous Trading	51
4.6	Mechanism of Day Ahead Markets.....	53
4.6.1	Process of Day Ahead Market	54
4.6.2	Bids of Day Ahead Markets.....	56
4.6.3	Market Operator.....	61
4.6.4	System Operator	62
4.6.5	Crimes and Sanctions in Day Ahead Markets	63
4.7	Day Ahead Market and Real Time Markets Comparisons.....	64
4.8	Hardware and Software Infrastructures of Day Ahead Markets	66
5	DAY AHEAD MARKETS IN TURKEY.....	71

5.1	Legal Basis of Turkish Day Ahead Market	69
5.2	Envisaged and Applied Model.....	70
5.3	Problems in Application	72
5.4	Criticisms on Turkish Day Ahead Market Model and Its Application	74
6	SOFTWARE APPLICATION OF DAY AHEAD MARKETS IN TURKEY ...	79
6.1	User Manual of Software Application	77
6.2	Examples on Day Ahead Market Using Uniform Pricing Model.....	80
6.2.1	Example for 1 Hour Time Interval	80
6.2.2	Example for 1 Hour Time Interval with Market Splitting	90
7	SIMULATION WITH REAL MARKET DATA.....	107
7.1	Example 1 with current situation	107
7.2	Example 1 with proposed model.....	110
7.3	Example 2 with current situation	114
7.4	Example 2 with proposed model.....	117
8	RESULTS AND FUTURE WORK.....	123
8.1	Results.....	123
8.2	Future Work.....	125
	REFERENCES.....	127
APPENDICES		
A	DAY AHEAD MARKET MODELS IN EUROPEAN COUNTRIES	129
B	ARTIFICIAL NEURAL NETWORK.....	140
B1	Application of ANN to STLF.....	142
C	REAL DAY AHEAD MARKET DATA.....	143
C1	Data for Chapter 7.1 and 7.2.....	143
C2	Data for Chapter 7.3 and 7.4.....	170

LIST OF TABLES

TABLES

Table 1 Illustration of Bids of market participants.....	45
Table 2 Buyer bidding example	58
Table 3 Mixed type of bidding example.....	59
Table 4 Block bid example.....	60
Table 5 Block bid in market bidding format	60
Table 6 Portfolio of Company A for Chapter 6.2.1 [21]	81
Table 7 Company A bids for Chapter 6.2.1.....	82
Table 8 Portfolio of Company B for Chapter 6.2.1 [21]	82
Table 9 Company B bids for Chapter 6.2.1	82
Table 10 Portfolio of Company C for Chapter 6.2.1 [21]	83
Table 11 Company C bids for Chapter 6.2.1	84
Table 12 Portfolio of Company D for Chapter 6.2.1 [21]	85
Table 13 Company D bids for Chapter 6.2.1.....	86
Table 14 Portfolio of Company A for Chapter 6.2.2 [21]	91
Table 15 Portfolio of Company B for Chapter 6.2.2 [21]	92
Table 16 Portfolio of Company C for Chapter 6.2.2 [21]	92
Table 17 Portfolio of Company D for Chapter 6.2.2 [21]	93
Table C1 Market bids for time interval 08:00-09:00.....	143
Table C2 Market bids for time interval 11:00-12:00.....	170

LIST OF FIGURES

FIGURES

Figure 1 Vertically Integrated Structure with Single Seller Model	6
Figure 2 Vertically Integrated Structure with Single Buyer Model.....	7
Figure 3 Vertically Unbundled Structure with Multiple Seller, Multiple Buyer Model	10
Figure 4 Average Fixed Cost and Average Variable Cost [12]	21
Figure 5 Average Cost [12].....	22
Figure 6 Long Run Average Cost [12].....	23
Figure 7 Short Run Average Cost Curve [12].....	23
Figure 8 Total Cost vs. Quantity Curve	24
Figure 9 Typical Marginal Cost Curve [13].....	25
Figure 10 Real Marginal Cost Curve [13]	26
Figure 11 Marginal Cost Curves of Plant A and Plant B [13]	26
Figure 12 Aggregated Marginal Cost Curves of Plant A and Plant B [13].....	27
Figure 13 Marginal Cost – Average Cost Relationship [12]	29
Figure 14 Long and Short Term Marginal Cost – Average Cost Relation [12].....	29
Figure 15 Regression Plot with load and temperature data.....	32
Figure 16 Expected load curve and historical curve	33
Figure 17 Mean Square Error vs. Epochs	33
Figure 18 Regression Plot with load, temperature and humidity data	34
Figure 19 Expected load curve and historical curve	35
Figure 20 Mean Square Error vs. Epochs	35
Figure 21 Structure of day ahead market	38
Figure 22 Supply Demand Balance example	46
Figure 23 Typical Supply Demand Curve	49
Figure 24 Uniform Price Auction and Pay As Bid Auction.....	51
Figure 25 Typical Day Ahead Market Algorithm [17]	55

Figure 26 Differences of market prices and bids in a day [17]	56
Figure 27 Hardware of day ahead market	68
Figure 28 Bids entered in excel for developed MATLAB software	77
Figure 29 Developed MATLAB Software - Excel integration	78
Figure 30 MATLAB screen after running code	78
Figure 31 Results of written MATLAB software in excel	79
Figure 32 Supply-Demand Balance output of developed software.....	80
Figure 33 Bids entered to developed software in xls format.....	89
Figure 34 Supply Demand Balance for Example 5.2.1	90
Figure 35 Excel output of developed software for Example 5.2.1	90
Figure 36 Zonal energy transmission among regions	91
Figure 37 Transmission limit is 10MW among zones for example 5.2.2.	93
Figure 38 Bids entered to MATLAB for Example 5.2.2	95
Figure 39 Market results of Example 5.2.2 generated by developed software	96
Figure 40 Zonal market price results generated by developed software.....	96
Figure 41 Balancing results for zone 1 in example 5.2.2 generated by developed software	97
Figure 42 Supply demand balance graph of zone 1 in example 5.2.2.....	97
Figure 43 Balancing results for zone 2 in example 5.2.2 generated by developed software	98
Figure 44 Supply demand balance graph of zone 2 in example 5.2.2.....	98
Figure 45 Transmission limit is 20MW among zones for example 5.2.2	100
Figure 46 Market results of Example 5.2.2 with 20MW transmission limit among regions, generated by developed software	101
Figure 47 Balancing results for zone 1 in example 5.2.2 with 20MW transmission limit, generated by developed software.....	101
Figure 48 Supply demand balance graph of zone 1 in example 5.2.2 with 20MW transmission limit among regions	102
Figure 49 Balancing results for zone 2 in example 5.2.2 with 20MW transmission limit, generated by developed software.....	102

Figure 50 Supply demand balance graph of zone 2 in example 5.2.2 with 20MW transmission limit among regions	103
Figure 51 Zonal market price results generated by developed software.....	105
Figure 52 Supply Demand Curve for time interval 08:00-09:00	107
Figure 53 Market results for time interval 08:00-09:00.....	108
Figure 53 Market results for time interval 08:00-09:00.....	109
Figure 53 Market results for time interval 08:00-09:00.....	110
Figure 54 Market clearing price and quantity of energy to be traded for time interval 08:00-09:00	110
Figure 55 Supply demand balance for Zone 1 for time interval 08:00-09:00.....	111
Figure 56 Supply demand balance for Zone 2 for time interval 08:00-09:00.....	111
Figure 57 Market results for time interval 08:00-09:00 with market splitting	112
Figure 57 Market results for time interval 08:00-09:00 with market splitting	113
Figure 58 Market clearing price and quantity of energy to be traded of each zone before power exchange among zones	113
Figure 59 Market clearing price and quantity of energy to be traded of each zone after power exchange among zones	114
Figure 60 Supply Demand Curve for time interval 11:00-12:00	114
Figure 61 Market results for time interval 11:00-12:00.....	115
Figure 61 Market results for time interval 11:00-12:00.....	116
Figure 62 Market clearing price and quantity of energy to be traded for time interval 11:00-12:00	117
Figure 63 Supply demand balance for Zone 1 for time interval 08:00-09:00.....	118
Figure 64 Supply demand balance for Zone 2 for time interval 11:00-12:00.....	118
Figure 65 Market results for time interval 11:00-12:00 with market splitting	119
Figure 65 Market results for time interval 11:00-12:00 with market splitting	120
Figure 66 Market clearing price and quantity of energy to be traded of each zone after power exchange among zones	120

CHAPTER 1

INTRODUCTION

Day Ahead Market is the trading of electricity one day ahead of actual energy transfer. Day Ahead Market gives market participants additional chance for trading electricity. Transmission lines have limits. Current Turkish day ahead electricity market transmission congestion is solved by intervention of market operator. Therefore, the resultant market price occurs higher than it should be. Moreover, in current Turkish day ahead electricity market structure, some regions of Turkey have scarcity of electricity after day ahead market auctions, because of the lack of transmission line management efficiently. Another problem with the current structure is that financing for upgrading transmission lines. Because of these reasons, instead of current day ahead market structure, it is essential to provide a new method in Turkish day ahead electricity market which can manage transmission congestions efficiently, as well as decreasing electricity scarcity percentage. As a result, Turkish day ahead market results lower electricity prices, as well as system operator is financed to improve grid infrastructure.

The objective of the thesis is to find an appropriate method to manage transmission congestion in Turkish day ahead electricity market. Moreover, a software is developed for analyzing current day ahead market structure in Turkey, as well as for the proposed method to the Turkish electricity market. The motivation is to apply market splitting structure to the current Turkish day ahead electricity market so that proposed market splitting method and developed software can be used in current and future Turkish day ahead electricity market.

Finland, Sweden, Alberta, Ontario, former England-Wales Pool, PJM and New England day ahead electricity markets have applied uniform pricing model. According to T. Krause, uniform pricing model works efficiently in absence of congestion on transmission lines [1]. Similarly, W. Hogan indicates that uniform pricing cannot guarantee an optimized allocation of energy in case of congestion [2]. W. Hogan supports his idea with New England electricity market example [2]. M. Xingwang also considers that uniform pricing method is incapable of achieving harmony between price efficiency and market liquidity [3].

In order to cope with the congestion management of uniform pricing model, T.Wu and Z.Alaywan demonstrate zonal pricing balances system and reaches higher efficiency than uniform pricing model [4]. Zonal pricing is based on market splitting. Although S. Borenstein criticizes zonal pricing method in that it has potential of resulting of congestion during high demand periods [5]; T.A.Johnsen could not find empirical evidence in a study on Norway [6].

Norway is the first country which adopted zonal pricing to the day ahead market on 1991. After Nord pool is created by Norway, Sweden and Finland; Nord pool applied zonal pricing method. Australia has been using zonal pricing since 1998.

In this thesis, first uniform pricing model is used to simulate Turkish day ahead electricity market. Zonal pricing examples are given so that zonal pricing is more efficient and can handle transmission congestions. Therefore, in this thesis uniform pricing model and zonal examples are compared in market efficiency and transmission congestion handling manner for Turkish electricity market.

The proposed Turkish Day Ahead electricity market utilizes market splitting, which is zonal pricing method. The contributions of the thesis are determining day ahead electricity market price more efficiently in case of transmission congestions in Turkish electricity market. Hence, the thesis also gives solution for financing of improvement of transmission lines. Another contribution of thesis is the development of software which can solve day ahead market problem in both market splitting and non-market splitting cases. Software is developed so as to solve all types of bids, including hourly bids, block bids and flexible bids. It is shown in the thesis that the use of market splitting solves transmission congestion problem and whole Turkish electricity generation system can disseminated in western regions, as well. Transmission capacity of grids can be upgraded by excess of payments in market.

CHAPTER 2

GENERAL OVERVIEW OF THE ELECTRICITY MARKET STRUCTURES

In this chapter, first, the overview of Electricity Market Structures is examined in order to give general idea about the existing popular market structures in Electricity Market. To achieve this, Electricity Market Structures are detailed according to their evolution. As a result of explaining the details of Electricity Market Structures, the main subject of this thesis “Day Ahead Markets” will have fundamentals at the end of Chapter 2.

2.1 Introduction

Electricity has always been a crucial subject for human beings and their civilizations in terms of the improvement of social development right after the electricity has been invented. As a social developer, electricity is the fundamental element for all parts of technology. As a technological developer, from agriculture to transportation, from education to medicine, from houses to cars, electricity is widely used. After the industrial developments in the world, electricity entered to all sides of our life.

All divisions of industry need electricity strongly. At this point, a question emerges. How these industrial companies and other retailers acquire electricity? The answer of this question was obvious more than two decades ago. Throughout the world, nearly all governments had the responsibility to produce electricity with help of their own managed generators; and this electricity production is called “generation”. Electricity generation was mainly based on coal in the world. However, producing the electricity was not the end point of responsibility of governments about electricity. Generated high voltage electricity has to be transferred via grids to the customers. This transferring operation is called “transmission”. Nevertheless, establishing grids need huge costs as establishing plants. That means governments were in charge of establishing and managing grids. The produced and transmitted energy has to be distributed to the variety of consumers at lower voltages, which is called “distribution”. As a result, governments before 1990s were in charge of not only generation, but also transmission and distribution. Therefore, states were the monopoly in electricity sector.

However, privatization, which is selling state owned companies to private investors or providing private investors’ participation, has become a trend in industries such as steel, water, gas, transportation in Worldwide. Before privatization, state owned companies were the monopolies in their area. These monopoly actions have exposed some crucial problems that had to be solved. Primarily, customers had no choice for choosing the goods from different sellers. Thus, economical efficiency was low. Secondly, the efficiency of production was low under monopoly. That is because there was no competition. In order to solve these problems, some countries contemplated privatization in some areas. As an

example of privatization, in 1950s, British Government privatized state owned British Steel Industry. In Germany, the famous car manufacturing company Volkswagen has been sold to small investors in 1961. The leader of Chile General Pinochet has adopted large-scale privatization in Chile in 1970s. In the early 1980s, energy market concept and privatization in electrical power systems was effectuated in Chile. From the view of rationality and transparency of energy pricing, Chilean model is considered to be successful. Although Chilean government was good at bringing rationality and transparency, their model confronted problems because of structural shape of market. Eventually, Chilean system suffered from system reliability. At the same times, Argentina was suffered from system reliability since most of state owned energy generation facilities had continuity problems which were resulting in system interruptions usually. In order to cease the discontinuity of energy, Argentina government decided to privatize state owned generators. Upon the Chilean trials, Argentina government evolved Chilean model by regulating the market by means of adopting strict limits on market as well as developing structure of payments to companies which sustain system reliability.

Above all privatization attempts in energy area, the most radical privatization programs appeared in 1980s in UK under the leadership of Margaret Thatcher. Under the leadership of Margaret Thatcher, gas, water and electricity was privatized so as to improve efficiency of production. Privatization of electricity generation in the time of Margaret Thatcher is the milestone for evolution of electricity sector. Although Chile embarked on the first changes of Electricity industry in 1978, British Electricity industry revolution is counted to be the most radical structural change in Electricity industry which is a role model for other commonwealth countries.

In spite of the structural changes has been realized by British Government in 1980s for Electricity industry, these structural changes were not primarily based on technical enhancements. The radical change of British Electricity industry mostly refers to the adoption of competition and regulation mechanism; this resulted in liberalized Electricity industry. Basically, liberalized Electricity industry has been adopted so that customers can choose their electricity [7]. British government worked on market types in order to decrease the affect of state in Electricity industry. As a result, new types of market models revealed.

As a commodity, electricity has difference characteristics than other commodities on the market. The primary difference is that the electricity cannot be stored which comes from its nature. Secondly, on the system, demands must be met by the supply at every second in which demand vary continuously, so supply of system must have also dynamic output quantity to meet the demand simultaneously. Since system has various demand changes, the whole system need to have a controller which controls the system continuity. Because of these properties of electricity, countries tried to investigate new market models for Electricity Industry. In consequence of privatization, deregulation concept, which is decreasing the power of government in Electricity industry, started to play role in market.

Currently in the world, there are various types of different market models, however, the idea has common ground. They all try to separate generation and retail from transmission and distribution in order to create a competitive and transparent market. By separating the parts of Electricity industry, these models create two types of electricity market. The first one is Wholesale Electricity Market and the second one is Retail Electricity Market.

In the next parts of this chapter, various electricity procurement methods and market models are examined so as to develop a fundamental for Day Ahead Markets which is the main topic of this thesis.

2.2 Single Seller Model

The most primitive model for electricity procurement is Single Seller Model. Single Seller model has been widely used by many countries before the privatization period of electricity generation. Before the privatization, electricity generation, transmission, distribution and supply was based on Vertical Integrated Structure.

In a Vertically Integrated Structure, from the generation until the end users, the architecture is separated into four parts. These four parts are generation, transmission, distribution and supply. Electricity is generated by plants. Generated electricity in power plants is transmitted via grids to the high voltage distribution centers. Distribution denotes power distribution which has less than 36kV potential difference. Distribution centers send electricity to supply points. At the end, supply point, which is responsible for billing, customer services, transports electricity to the end users. All four divisions are under the management of government and these divisions are working together to plan the process of supply of electricity. Such a divided system is called Vertically Integrated Structure. Vertically Integrated Structure is illustrated in Figure 1. Each division has its own management, but work together under the cap of government. Thus, government has all control and regulation over all system. Dispatch of generation is central. There is no Independent Power Plants. For the Vertically Integrated Structure, all parts of system are regulated. Since there is no electricity market; government control generation, transmission, distribution, supply which results with decision of wholesale price and the retail price of electricity by government, without market power.

In Turkey, before 1993, Turkish Electricity Authority, abbreviated as TEK, was responsible from all electricity operation, which includes generation, transmission, distribution and supply of electricity. TEK was managed by state.

Single Seller model stands on the generation part of electricity. For Single Seller Model, generation is managed by government. Government makes investment on plants, and manages it by itself. There are no private investors which can install plants, produce electricity and sell it in the market. This brings Monopoly in production phase of electricity.

Although Single Seller Model is not widespread in commonwealth countries such as European countries, United States of America and far eastern countries; there are still some countries which still utilize Single Seller Model. Such countries are not based on pure liberal economy in electricity. Since constructing generation plants and transmission grids requires huge amounts of capital, in most countries governments stand the racket on production phase. By means of the capital of government, almost every country has built its own generation plants as well as transmission grids. However, these huge costs are covered by the prices of electricity which reflects to the people. Investments also bring huge economical risks which are also covered by the electricity users.

As the years passed, people started to use much electricity because of the technological and industrial developments. Therefore, old fashioned power plants started not to meet the demands. However, repairing old fashioned plants and building new ones are costly. Correspondingly, people started to discover new types of power plants. Not only because of the costs of new plants and repairing, but also the low economical efficiency and low quality of electricity is the factor of getting rid of this model and opening production phase to the private investors.

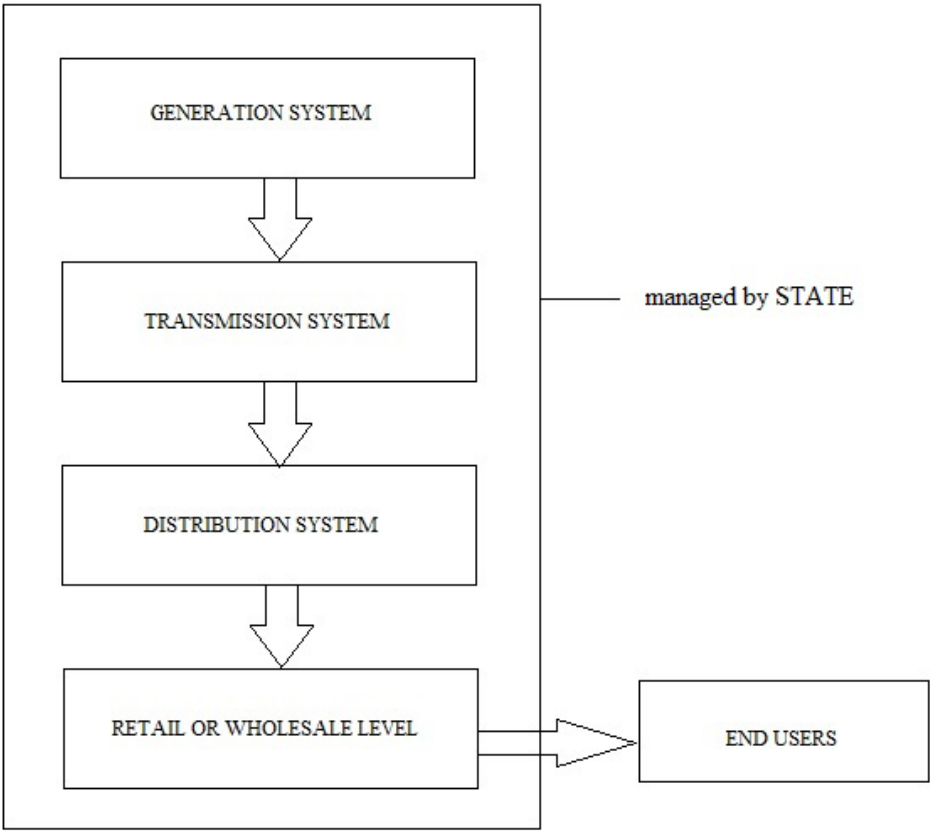

Figure 1 Vertically Integrated Structure with Single Seller Model

2.3 Single Buyer Model

For Single Buyer Model, Electricity generation and distribution is separated from each other. Electricity generation is held by Independent Power Producer, abbreviated as IPPs, which are managed by private companies. Enterprise of private companies forms privatization, however since distribution is fully under control of state, generating market for electricity supply and demand remains primitive. Therefore, Single Buyer Model is a form of imperfect competition.

Single Buyer Model emerged in developing countries in 1990s. Upon the huge demands of electricity and shortages of electricity usually, governments decided to authorize private companies to build power plants which is called IPP. IPPs were vested to generated power and sell it to the state owned power distribution company. Since state owned power distribution company is the only one buyer of electricity after generation process; this model is called Monopsony. Owing to the chance of state distribution company to dictate terms to generators in market, Monopsony is considered as imperfect competition. Figure 2 demonstrates the structure of Single Buyer Model [10].

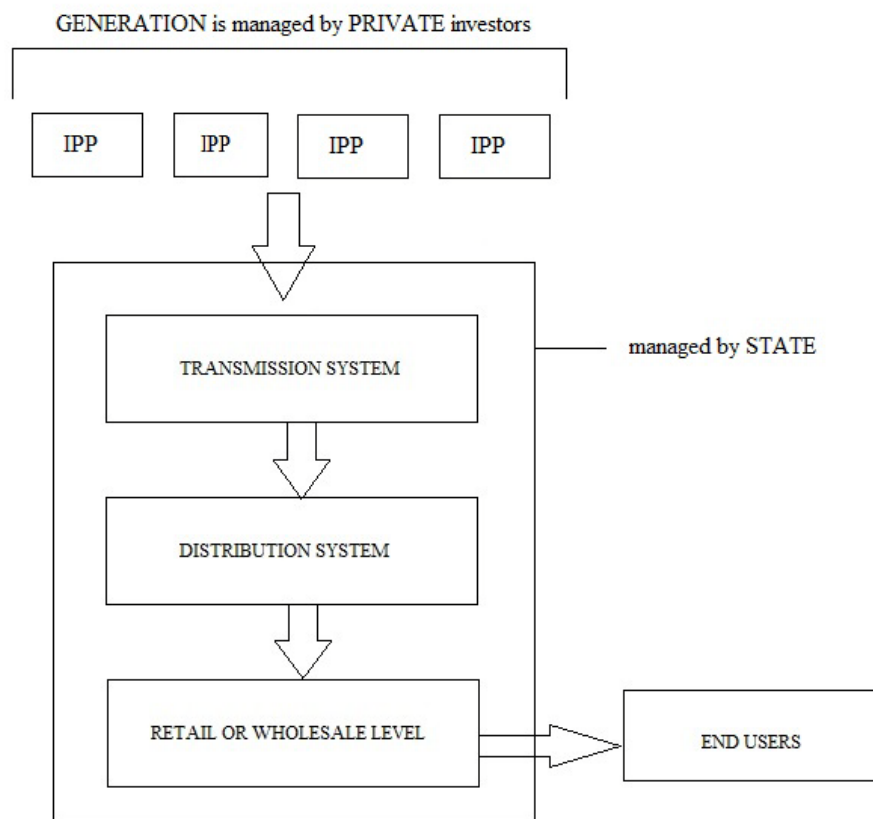

Figure 2 Vertically Integrated Structure with Single Buyer Model

IPPs' generations were based on long-term power purchasing contracts in which the contract is signed between state-owned distribution company and IPPs. In order to save the private power plants from risks of demand amount, take-or-pay type agreements play role in contract. As a result, private investors do not make loss if demand is less than the previously forecasted demand.

Single Buyer Model has some advantages as follows:

- The only distribution company is state-owned company. Distribution company buys electricity from IPPs and sells. State owned Transmission Company responsible for undertaking real time dispatch. Therefore, Transmission Company has perfect opportunity to balance supply and demand.
- Since there are no bilateral agreements in this model, electricity flow does not depend on contract agreements, on the contrary electricity flow depend on only physical laws rather than contracts. Upon real time dispatch, electricity flows directly from generators to loads without interfering transmission line from 3rd parties. Therefore, it is easy to establish transmission line fluidity. There is less chance to occur congestion in transmission line.
- Private investors have eagerness to anticipate in Single Buyer Model due to the contracts which protects generators from losses. Eventually, establishing power generator and managing generator becomes bankable investment.

Although Single Buyer has advantages as mentioned above, it has also critical disadvantages that are why commonwealth countries get rid of Single Buyer System.

Government knows about the demand of electricity which results in decision of need for installing new capacity. Each installed generator by investors leads to take-or-pay contracts to protect generators. However, these take-or-pay contracts results with huge economical losses for state if demand is not forecasted accurately for the long term by state owned Transmission Company. Even if forecast has high percentages of success, take-or-pay contracts are burden for government. As a result government makes loss after paying huge amounts of money because of contracts.

Secondly, since government is the decision mechanism of installing new capacities, there can reveal many problems where corrupt can take place. When the government has low control mechanism and not sufficient laws over governmental decisions, government officials can abuse the installation of new generators. Although there is not real need for installation of new plants for supply demand match, such governmental officials can accept establishing new generators for the sake of themselves. Such installments bring huge costs for government but can bring huge incomes for government officials and private investors. Such model was applied in countries such as Hungary, Indonesia, Pakistan and Thailand [10].

Thus, even Single Buyer Model has advantages; this model has some crucial disadvantages which makes this model difficult to be applied because of the reasons mentioned above. Since Single Buyer Model is a regulated model and semi privatized; this model is counted to be the transition from state owned electricity to market model.

2.4 Multiple Seller Multiple Buyer Model

Single Buyer demonstrates a primitive version of market competition among generators. Conversely, Multiple Seller Multiple Buyer Model is an improved version of competition. In contrast with Monopoly and Monopsony, Multiple Seller Multiple Buyer Model represents a wholesale market competition among companies. Since there are multiple buyers and sellers, it lays the groundwork for transition from fully regulated market to partly deregulated competitive market in generation and wholesale, retail sales of electricity.

Multiple Seller Multiple Buyer Model is also an unbundled structure in contrast with Vertically Integrated System. For an unbundled structure, IPPs are responsible for generating electricity and they sell their outputs to the system operator or several private wholesaler or retail seller companies depending on the type of market model. Short term markets such as day ahead, intraday and balancing markets provide mechanism in order to match supply and demand in whole system. Pools and Bilateral Contracts plays role under Multiple Seller Multiple Buyer Model for long term balancing.

As a market style Multiple Seller Multiple Buyer Model is liberal one and it exhibits a market competition in which price of electricity is determined by supply demand balance which results in competition, hence more efficient prices. Moreover, Multiple Seller Multiple Buyer Model reveals more transparent electricity prices than Single Seller or Single Buyer Model because of the open market structure and unbundled structure of electricity. Figure 3 depicts Multiple Seller Multiple Buyer Model in an unbundled structure of electricity procurement management.

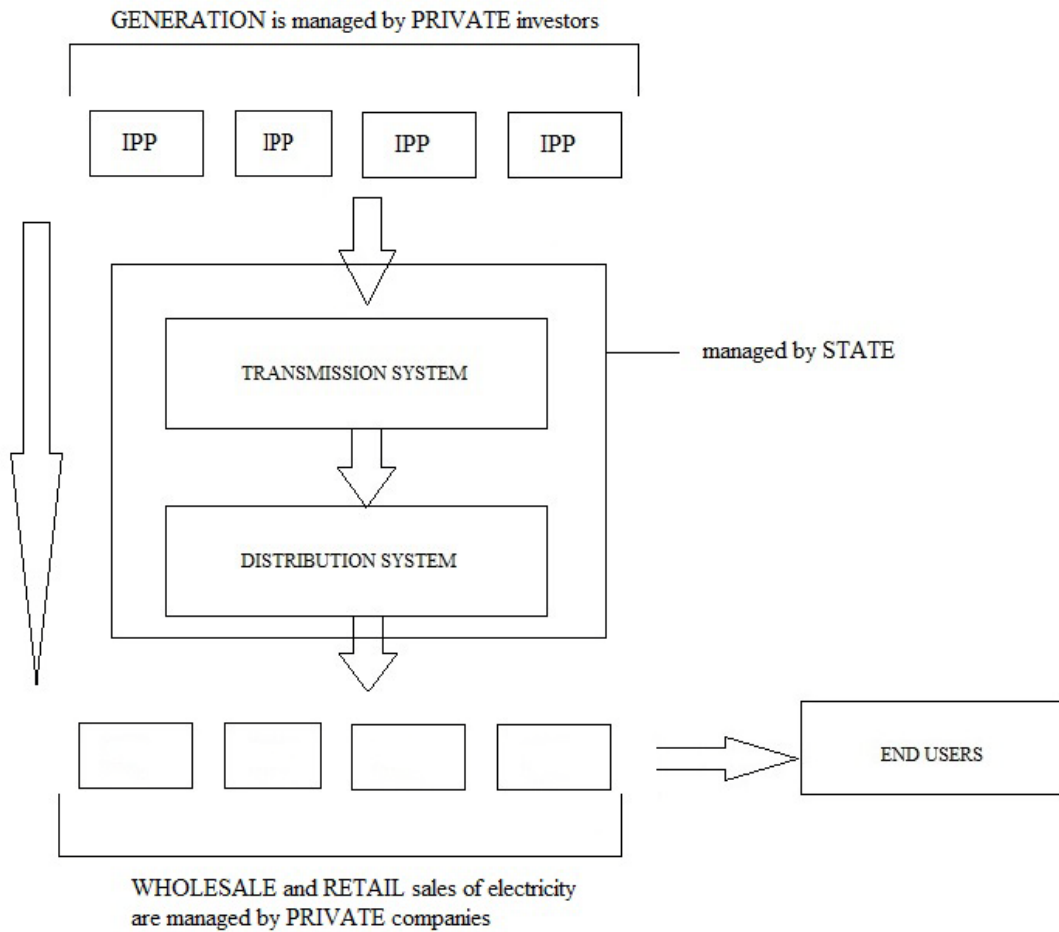

Figure 3 Vertically Unbundled Structure with Multiple Seller, Multiple Buyer Model

2.4.1 Pool Model

Pool model is unbundled system; generation, transmission and distribution are separated as in vertically integrated system, with a difference that some parts of vertically integrated parts are managed by private investors. The target of unbundling is to make distinction transmission and distribution from generation and wholesale or retail selling. Generation of electricity is accomplished by IPPs. Produced electricity is presented to the system operator which is a centralized company and responsible for dispatch of electricity. Demands are usually based on the forecast; meaning that there is no demand bids given by distribution companies. Demand is purely based on the forecast of system operator. Therefore, supply and demand is matched and marginal electricity price is determined. Unit Commitment problem is solved by system operator. Unit commitment problem involves which generators, at what time has to be operated or not operated, where and how much amount of energy is to be supplied.

All producers have to participate in pool market. Eventually, all energy is balanced in a pool; supply and demand continuously matched and energy coordination problem disappears. Pool Model has been operated in many states in USA, however, after energy crisis in California in 2000, Pool model needed to be revised and other types of markets were started to be implemented in many USA markets.

Day ahead, real time markets are the markets running in Pool Model. The bids are mostly submitted to the system operator one day ahead of the transfer on an hourly basis. Based on the submitted bids and the forecasted demand in a given period of time; System Operator makes unit commitment with the aim of achieving least cost generation. On the day of energy transfer, unplanned situations such as fluctuations in demand, supply shortage can arise. System Operator needs to solve such unplanned situations. To hedge against such unplanned situations, contracts are signed before trading which is called Contracts for Differences. Unit Commitment problem is not solved according to contracts. Contracts provide only hedge against system demand and supply fluctuations.

In order to solve Unit Commitment problem, system operator need all data related with all IPPs' start up costs, generation costs, shut down costs and other costs. IPPs' bid format contains amount of production capacity as well as costs related with start up, shut down and generation. According to the data submitted to the system operator by IPPs, system operator needs to solve unit commitment problem with aim of minimizing total system generation cost. However, this calculation and unit commitment process requires complex calculations which complicate duty of system operator. Such a complicated algorithm has tendency to give wrong results.

For a fully competitive market, if IPPs reflect their costs structure correctly to the system operator, pool model is a chance for utilizing all sources effectively because a system operator has all information about produced amounts of electricity and system operator realizes all dispatch. Moreover, coordination of transmission gets easy because system operator completes Price Based Unit Commitment by itself and can control all grids whether congestion occurs or not. Upon the advantages, on the other hand, as a course of IPPs, IPPs invest for more and more profit. Bearing in mind that IPPs are independent private companies and they have all the right for presenting their own costs untruly manner; at the end of price based unit commitment process, misleading and high electricity prices may appear in market. Finally, IPPs may earn profit more than they deserved, conversely consumers need to pay for electricity more than it has to be in real. Consequently, Power Pool Model has high tendency to be manipulated which breaks fully fair competitive market. Market is designated so as to achieve minimum price; but with Pool Model, it is difficult to achieve fully optimum result because of the reasons listed above.

Another crucial disadvantage of Pool Model is that demand side of market has not much contribution to the market. Although private companies exist in wholesale or retail sales of electricity as demand side, these companies do not have chance to bid for their desired buying price versus electricity amount. The only factor that determines the market price of

electricity is generators, i.e. IPPs. Therefore, resultant market is only driven by one side; the other side has not much power on determining prices. Hence, exploitation may occur since it is one sided system. Such a market is not counted to be a fair and fully liberalized market; due to not all participants have enough strength to determine the market price. Buyers should accept the resultant market price whatever the price of electricity is [8].

Many states of USA adopted Pool model, however pool model failed because of the reasons mentioned above. Especially the Electricity Crisis in California in 2000, led to revise pool model and adopting new types of market models in California. Following California, many states in USA changed their electricity trading from Pool Model to another models, especially based on bilateral contracts.

After the privatization of electricity generation and sales in UK, pool model started to be applied as the model. As a classical Pool Model, there was a centralized system operator. Generation has been completed by two companies. There were only two generators which were supplying electricity to throughout UK by means of Pool Model. However, such duopoly Pool Model resulted with determination of electricity price depended only by these two companies. Two companies were holding the market power and they were increasing the electricity price which in last led many arguments and criticisms over system. It was observed that such a Pool Model cares only generators, conversely buyers have no market power for determining the electricity price. Electricity consumers started to complain about this issue that the prices were too high. Thus, UK started to adopt another models, especially based on bilateral contract.

2.4.2 Bilateral Contract Model

Bilateral contract model emerged after the disadvantages of Pool Model have been argued. In UK, Pool model was presenting huge electricity prices in that only suppliers were controlling the electricity price because of the nature of Pool Model explained in Pool Model Section. Two generation companies were dominating the market and this was not a liberalized economy. Liberalization aims to achieve least price and transparency in price decisions in which consumers can choose commodity from market freely. As a result, UK adopted Bilateral Contract Model. UK experience is a good reform example on switching from pool model to bilateral contract model. Moreover, bilateral contract model is the most widespread method in electricity trading throughout world currently.

Bilateral Contract Model is mainly based on free market. Contracts are the main instruments of bilateral contract model. System operator has to take contracts into consideration in transmission process. The aim of Bilateral Contract Model is providing liberty for both suppliers and consumers while buying or selling electricity. Suppliers can sell their electricity with either long term or short term contracts. In the same manner, consumers can purchase electricity with either long term or short term contracts. Hence, bilateral agreements introduce the most effective method for cost minimal dispatch of electricity; because companies make their own decision and sign contract according to their agreements.

There is no pressure on any company to sign an agreement or compulsion for trading and contracts. Both buyers and sellers have freedom to whom and in which price they will realize trading action. This kind of model is basically looks like other commodities; free market. Such a free market has its own dynamics whilst determining price. There is no one sided power or invisible hand in determining market price. Both sides of trade have affect on determining the price of electricity. Such a market results with transparency in prices. Transparency of prices obstacle unjustified benefit. Electricity price comes to its own value, not an artificially incremented price. Hence, market makes its price by itself. However, a free market can work well only if rights and control mechanisms are described and applied well. If the rights and control mechanisms are not well defined and applied, problems emerge in trading action [8].

Electricity is a commodity in which it is transferred via grids and these grids have limited transmission capacities. Therefore, not everyone can utilize grids as it wants. It must have a controller. Electrical grids are to be controlled by an independent system operator which must schedule the transmission. Thus, signing a contract with a buyer or seller does not solve electricity trading issue. There is still a need for center which dispatches transmission. For this transmission, some congestion, some problems in application process occur. Such problems are the most disadvantageous part of Bilateral Contract model. These problems need to be solved by system operator. In order these problems to be solved by system operator, all agreements has to be presented to the impartial system operator by traders.

Although generators have chance to manipulate market price of electricity and have much profit in pool model, Bilateral Contract Model introduce other acquisitions for producers. For a generator, it does not only need to be supplier. If it is profitable, a generator can be a buyer first, and can sell this electricity. Thus, generator exploiter should conduct perfect cost analysis and depending on the cost analysis and the price of market, generator exploiter should decide whether buying electricity from other suppliers or producing electricity is more profitable. Such choices in market make investors to invest in generator side of market.

For Bilateral Contracts Model, not all generators and all capacities may be sold out with contracts in ideal. Generators may not find buyers or they may not sell their full capacity always. Similarly, generators and/or wholesalers and/or retailer sellers may not find the most suitable agreement in market to sign contract. Thus, if market does not have a mechanism for selling or buying lack electricity, prices can still increase artificially. In order to cope with scarcity and results of scarcity of electricity, day ahead market takes place. In the cases which day ahead market does not exist, economical efficiency can be low, and electricity price can be high that is the problem of other models. By attending day ahead auctions, buyers can bid for their deficient energy. Correlatively, sellers can bid for their unused capacity. Consecutively, Day ahead markets are the crucial markets involves in Bilateral Contract Model which is the main topic of thesis.

2.4.3 Balancing and Settlement Problem of Bilateral Contract Model

Bilateral Contract Model gives freedom to market participants to trade freely. Any generator in the market can sell the output to any buyer with any price depending on two sided agreed bilateral contract. In the same manner, any buyer can buy electricity from any generator or any other trader in the market. Such market is valid for any other commodity. However, due to the nature of electricity, electricity differs from other commodities in the market.

Primarily, electricity supply and demand balance must be matched at any time in the whole system. Matching of electricity implies that at any time in a grid, supplied and demanded energy must be equal. There must not be surplus of electricity; similarly, not less electricity should be produced. This is because of the quality of electricity on grids. If supplied and demanded electricity is not equal in system, frequency of electricity change and quality of electricity decreases. Quality electricity indicates that frequency of electricity is 50 Hz.

Single Buyer Model is a form of primitive privatization model as explained in Chapter 2.3. There exist many generators for Single Buyer Model, owned and managed by private investors. Single Buyer model offers opportunities to investors to invest on generation part of electricity. Single Buyer Model is vertically integrated too but generation of electricity depends on private investors' companies. However, the produced electricity is purchased by only Government owned Distribution Company and is reached to the end users. Therefore, as in Single Seller Model, state owned Transmission Company has all control in dispatch of electricity according to forecasted demand. Such a system does not reveal any problem for balancing electricity as in Single Seller Model. All supply and demand is under control of state owned transmission company. As a consequence, there is no balancing problem in the system.

Pool model is more privatized model rather than Single Seller and Single Buyer Model in terms of market structure. For pool model, generators are privatized too and they send their supply bids to central system operator which decides and responsible for minimal cost dispatch. For pure Pool model, there is no need for balancing mechanism in that energy is dispatched by central system operator. Pool model has advantage that supply demand balance can be matched easily in every second in a system, because dispatch mechanism is system operator and system operator decides energy flow.

Bilateral Contract Model is the most privatized and liberalized model in that private investors invest in generation, participate in wholesale and retail selling. As a course of nature, electricity must be carried out via limited capacity grids, transmission must be under control of impartial system operator as explained in Chapter 2.4.2. Traders among market have freedom to trade with any traders. Trading contracts can be signed for both long term and short term. Any contract can take in place in market; length of contract, amount of energy, price and all other rules are freely agreed by traders. That is why Bilateral Contract Model is the most liberalized. Such freedom brings transfer problems because grids are

limited and congestions can occur on the lines. Thus, a balancing mechanism needs to be installed to system.

Moreover, one generator can seller too as well as supplier. All depends on the profit of generator and decision of generator executives. Similarly, sellers have their own decisions while signing contracts according to the demand. There is no restriction for traders on signing contract. Anyone can sign any agreement. Such an open market may bring some unused capacities for generators. Generators may have capacity to sell more energy, yet cannot find a profitable contract to sign. Buyers may not also sign profitable contracts; that is still seeking for lack of electricity. In such cases for Bilateral Contract Model, balancing mechanisms overcome scarcity of energy and economical profit problem. Day Ahead Market, Balancing Power Markets, Ancillary Services are the core Balancing and Settlement Mechanisms in Bilateral Contract Model.

2.4.3.1 Day Ahead Markets

Day Ahead Market is the main Balancing mechanism of Bilateral Contract Model. Any trader can attend in Day Ahead Market. Day Ahead Market is not compulsory to attend. When buyers or sellers contemplate that bilateral contract is not enough for their companies and desire to trade electricity more; not only for profit but also for need too, buyers or sellers have chance to trade in Day Ahead Market. Bilateral Contract is not the only way for electricity trading in Bilateral Contract Model. Day Ahead Market brings flexibility to traders while trading energy.

Day Ahead Market is the market in which electricity trading is completed one day ahead of physical transfer of electricity. 24 hours of a day is divided into 24 equal periods and for each 1 hour period, traders bid their offer as explained in Chapter 4. For auction Day Ahead Market model, according to submitted supply and demand bids, system operator matches system balance physically and market clearing price of electricity is set. It is obvious that market clearing price of electricity is designated by bids of sellers and buyers. There is not a virtual hand which determines market price. Wholesale and/or retail sales companies who have not signed bilateral contract do not suffer from electricity shortage, because day ahead market take place one day ahead of actual trading. Sellers which have not used their full production capacity can sell their unused capacity that is left from signed Bilateral Contracts. A production company can have a signed bilateral contract with a buyer. This production company may encounter production problem or any other problem, but depending on the contract it must supply electricity to contracted buyer. Day Ahead Market gives opportunity to production companies to purchase electricity from market and sell it to the previously contracted buyer at the time of previously determined transfer date. Therefore, Day Ahead Market overcomes balancing problems in most cases.

2.4.3.2 Real Time Markets

Since energy is traded one day ahead of physical transfer of energy in day ahead market, in real time, system can encounter supply demand imbalance. Imbalances occur in the system because of the reasons as follows:

- 1) Sellers may not enter Day Ahead Market and decides to sell the unsold capacity in real market
- 2) Sellers could enter Day Ahead Market but their bid maybe not accepted and they may have still unsold capacities to sell
- 3) Buyers can have more demand than previously forecasted demand
- 4) Sellers may encounter problem for supplying energy. Plant can be spoiled; energy shortage happen which results in imbalance.

Therefore imbalances occur in system. Such imbalances have to be recovered by system operator. System operator need to take precautions for imbalances. Hence, Real Time Market is second type Balancing and Settlement mechanism of Bilateral Contract Model. Real Time Market is also operated by independent market operator. Traders can bid for their demand or unused capacity. Unlike Day Ahead Market, Real Time Market is obligatory to attend. All sellers should bid for unused capacity and sellers must bid for their lack of demand. Real Time Market is the last exit for balancing mechanism of system. Real Time Market starts to operate after closing of Day Ahead Market.

In order to surmount the above physical and contractual imbalances; Real Time Market has to be applied in Bilateral Contract Model. Real Time Markets result with more system security and reliability after Bilateral Contract and Day Ahead Market. This is because Real Time Markets are the latest step for balancing supply and demand.

CHAPTER 3

COST MODELLING, MARGINAL COST, SHORT TERM DEMAND FORECAST

3.1 Cost Modeling

Cost models help business owners and managers to comprehend the cost for certain businesses. By means of cost modeling algorithms, companies can have basic information relating to resources, such as raw materials and laboring, and transform the data into useful costs for determining the price of commodities. Many different companies from all sectors utilize cost models in their business operations. The main reason to utilize cost modeling algorithms is to maximize the profit of their own companies.

Adoption of Bilateral Contract Model to the Electricity Market brings some challenges to the generators. Since Bilateral Contract Model is a free model in which buyers and sellers can sign contracts for short time duration or long term traders, traders are free to determine the price of electricity when they sign electricity selling and/or buying price for the desired quantity of electricity. Thus, generators should offer logical bids to buyers in that generators can sell electricity and make profit.

Bilateral Model brings Balancing and Settlement Mechanisms to the Market as explained in Chapter 2. Day Ahead Market and Real Time requires logical and reachable bids by the generators. Otherwise they have no chance to win the auctions. Bids are determined based on marginal costs as all other commodities in market.

Producing and after production; selling is not the only chance for generators for trading in Bilateral Contract Model. Generators should buy electricity via Day Ahead Market and can sell it to other buyers. Similarly, generators can buy electricity from other generators, and then can sell it to other buyers. Generators can bid to sell their electricity to Day Ahead Market also. All choices are dependent to the generator. Except attending Real time Market, nothing is mandatory. Management of Generators calculates all variations, and decides the choice; whether they will produce electricity and sell it, or buy it via Day Ahead Market or Bilateral Contract and then selling it to the other buyers via Bilateral Market.

Calculations are complex; hence, generator executives should give right decisions in order to make more profit. Therefore, obtaining cost model for their generators are critical issue to be determined. After cost modeling and analysis, generator executives can decide which buying or selling action is the best choice for highest profit for their companies. Start up costs, operational costs and shut down costs have to be computed in tight manner so that generators can make more profit. Therefore, wrong cost models results with fewer profits for generators.

There are many different technologies used for Production Companies. Some plants are Combined Cycle Gas Turbine (abbreviated as CCGT) Plant, CCGT Plant with Carbon Capture and Storage (abbreviated as CCS), Advanced Supercritical (abbreviated as ASC) coal Plant with Flue Gas Desulphurisation (abbreviated as FGD), ASC Coal Plant with FGD and CCS, Integrated Gasification Combined Cycle (abbreviated as IGCC), Nuclear Power Plant, Pumped storage hydro-electric plant, Open Cycle Gas Turbine (abbreviated as OCGT), Combined Heat and Power (abbreviated as CHP) Plant, Gas fired CHP Plant. All of has different cost model results. Costs are classified as “fixed costs” and “variable costs”. Cost modeling calculations changes from generator type to generator type. However, there are fundamental input parameters which are used while cost modeling. These fundamental parameters can be listed as follows [9]:

- Timings about development, construction and decommissioning period of plant
- Technical data of plants. Technical data include heat, power outputs of plant, efficiency of plant, load factor of plant.
- Capital costs of plant. Capital costs are related with design and development processes of plant. Regulatory and licensing costs are other costs. Moreover, construction and infrastructure costs are capital costs, as well.
- Operational and maintenance costs of plants. Operational and maintenance costs include fixed and variable maintenance costs, system charges due to usages and insurance.
- Other costs are related with fuel prices, exchange rates and other costs.

3.1.1 Data Sources

Data sources of inputs of cost modeling are crucial step while preparing cost modeling in order to get accurate results after cost modeling process. In general, costs and technical parameters are obtained from suitable reference plants used within related country or other countries. As it is needed, cost databases and modeling software is utilized to have data. By means of such software, companies have chance to model the costs for each type of plants by entering specific data. Using such software, generator companies can smooth their costs according to the distance from their desired level of total costs. Literature search is also another method for obtaining data inputs. This step is extensively used when a new type technology of plan is installed. Since there is not previous data can be utilized, literature search helps companies for data required about new type of plants [9].

3.1.1.1 Timing

Timings of plants are important parameters for cost modeling of generators. Timings of plants include the development, construction, operational and decommissioning periods.

Development period includes feasibility researches, tender documents, bid reviews, environment evaluations, permission and procedures get by government.

Construction period is other long process in which some parts or mechanisms can be obtained by ordering. Such purchasing orders of plant to other companies can make the construction period longer due to unexpected lead times. As an example, for construction of CCGT plants, construction period is widened due to lead time of large rotors which can be designed and produced in around 18 months. Therefore, overall construction period reaches to 24 months.

Operational period is the duration of a plant in which it can work. Operational period data is obtained by the past experiences and generally known facts. For example, it is known that IGCC plants have less life longs compared to CCS plants. CCS plants have 20-25 years of lifetime, whereas IGCC plants have 5 years lifetime.

Decommissioning period is the duration when a plant is getting ready to get out working. As an example, IGCC with CCS plants need 6 months more than coal plants for IGCC plants for decommissioning period.

3.1.1.2 Technical Data

Technical data is related with net output power, efficiency, load factors, auxiliary power of plant.

Net output power is a predetermined data of generator designers. According to output which is modeled in MW, is used in cost modeling calculations.

Net efficiency denotes the ratio between output power used and input power of plant. Input power is also known by the construction model of generation plant. Thus, efficiency is calculated. However, as the years pass, efficiency of a plant decreases. Therefore, for net efficiency calculations, precautions for making efficiency higher in later years are taken into consideration.

Load factor of a plant is related with the load that can be applied to a plant during operational processes. Most plants are assumed to have 100% load factor for dispatchable loads, whereas for OCGT plant, load factor is not 100% because of economical restrictions. Auxiliary power defines the amount of power that must be supplied to a plant as auxiliary. For example, offshore wind technology needs auxiliary power to continue operating [9].

3.1.1.3 Capital Costs

Capital costs data includes development cost, regulatory and licensing costs, and infrastructure costs.

Development Costs are related with estimate for designing and development activities, tendering, contracting, fuel sourcing and consulting costs.

Regulatory and Licensing Costs are determined by laws and legislations. Regulatory and Licensing Costs also vary from a plant type to another type depending on the country [9].

Infrastructure Costs are the costs of a plant related with construction of High Voltage Electrical connections, gas as well as CO₂ pipelines to the main system of transmission.

3.1.1.4 Operating Costs

Operating Costs include Operational and Management costs, insurance, Decommissioning costs.

Operational and Management Costs includes fixed cost and variable costs. These costs include start up costs, operating costs, shut down costs, workmanship costs.

Insurance is related with the insurance contracts of a plant. Insurance costs can vary dramatically since capital costs and risk estimations of plant types can be different. As in new technology cases, since there are not enough data and experience, plants require to have much higher prices of insurance, on the contrary well known technologies are not insured with high prices because of low risks [9].

Decommissioning costs are the costs related with right after finishing the lifetime of a plant.

3.1.2 Cost Curves

Productively efficient companies utilize cost curves so as to find the point where production is optimized, means companies minimize their costs. Profit maximizing companies utilize cost curves to make highest amount of profits in free market.

Cost curves are differentiated in two parts, short run and long run. Generators have both short run and long run costs. Short run costs are the costs which are paid and cost finishes in short time. Long run costs are at type of periodical cost in long term for generators.

There is an objective function has to be minimized while regarding the constraints.

For power generation of a plant, objective function is described as [11]:

$$\text{Minimize } \Sigma (\text{Variable costs} + \text{Fixed costs})$$

Where constraints are,

- $\Sigma \text{ Output Power} \geq \text{Total Demand (MWh)}$
- $\Sigma \text{ Ramp Up rate} \geq \text{Max load change (MW/min)}$
- $\Sigma \text{ Ramp Down rate} \geq \text{Max load change (MW/min)}$

- Σ Base load plant minimum capacity \leq Year minimum load level (MW)
- Σ Governor Free Response Quality \geq Max unit capacity (MW)

3.1.2.1 Short Run

In the short run, some costs are regarded as fixed, while some regarded as variable. Fixed costs are the costs which are not related with the generated amount of power. As an example, an entrepreneur desire to establish a generator and purchase a land by paying a certain price. Since purchasing price is not related with the generated amount of power, purchasing price becomes a fixed cost in short run. Variable costs are directly related with generated amount of power. Fuel costs are related with variable costs, because as generated amount of power increases, fuel costs also increase.

Cost and price is given with 1st order equation as follows:

$$f(x)=y=mx + n$$

- where, x is amount of power
- m is variable cost constant
- n is fixed cost
- xm is variable cost
- y is cost at x amount quantity of power

Mathematically, the average variable cost, abbreviated as AVC; average fixed cost, abbreviated as AFC are given as in the Figure 4:

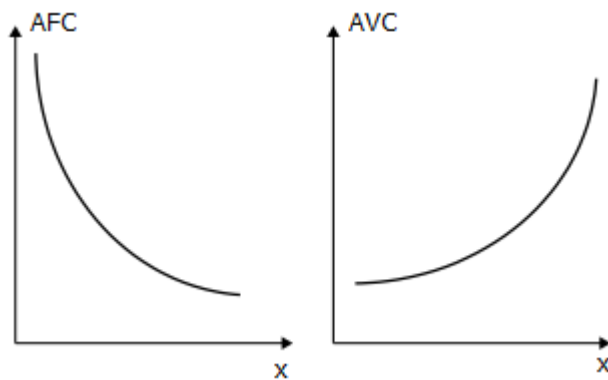

Figure 4 Average Fixed Cost and Average Variable Cost [12]

Gathering average fixed cost and average variable cost; average cost of short term is obtained which is abbreviated as AC. Hence, average cost is as in Figure 5:

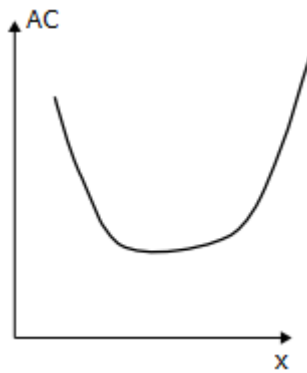

Figure 5 Average Cost [12]

For not a huge amounts of quantities, variable cost increases in linear manner as output increases. Thus, the average variable cost remains constant. This can be observe from the equation $y=mx+n$.

In theory, if production efficiency is raised as output production is increased, average variable cost becomes decreasing as output power increases. Although variable cost deems to be constant, in reality, as the amount of generated power increases dramatically, average variable cost tends to increase exponentially due to restrictions of some fixed conditions. Thus, average variable cost graph turns out as in Figure 4. As an example, a plant can be desired to operate more than its actual capacity. Thus, a company needs to pay more for workmanship, maintenance of equipments more often by decreasing efficiency. Gathering average fixed cost vs. amount of output power produced, average variable cost vs. amount of output power produced together; average cost vs. amount of output power produced graph is determined. As depicted in Figure 5, average cost curve looks like a typical U-curve [12].

3.1.2.2 Long Run

Unlike short run costs, long run costs are not dominated by fixed costs since there is no fixed cost in long term. This is because; all conditions can change after long time and Generator Company may decide to get out of electricity generation. Hence, only quasi-fixed costs dominate long run costs. Companies are exposed to quasi-fixed costs when plant is operating; conversely companies are not exposed to quasi-fixed costs when plant is not operating. Running up a plant can be given as an example. In order to run a plant, fuel is required and fuel is fixed cost commodity. In case of not running up the plant, no fuel is need, so no cost is incurred to Generator Company; although fuel is fixed cost.

As a result, average cost in long term tends to be U-curve. A typical figure for long run costs is depicted in Figure 6 [12].

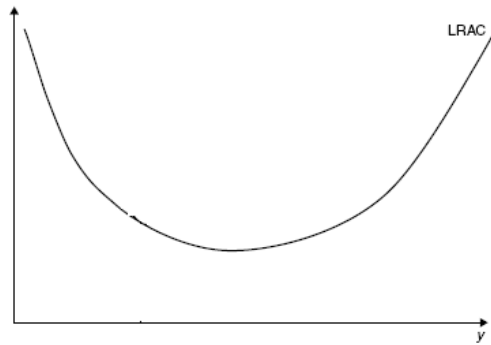

Figure 6 Long Run Average Cost [12]

3.1.2.2.1 Short Run - Long Run Cost Relationship

A producer can decrease production cost by adjusting parameters of generation in long term. Conversely, since short term is restricted by fixed costs, for short term, a producer is not as flexible as in long term. Hence, short run average cost prices are always more than the long term average cost price. However, when fixed costs are optimized in short term, both long term and short term average costs are equal at a unique amount of generation, denoted as y^* in Figure 7 [12].

A company can minimize short term short term production by taking other production factors into consideration for different amount of product. Thus, average long term costs envelopes short term costs as depicted in Figure 7. In long run, fixed costs do not exist.

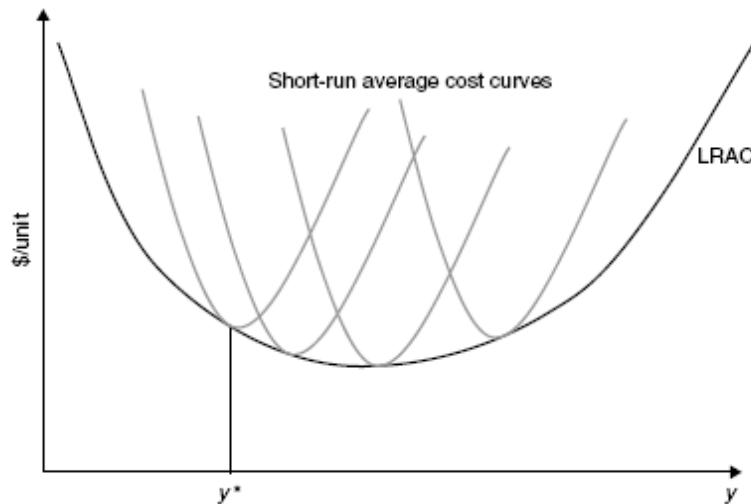

Figure 7 Short Run Average Cost Curve [12]

Cost Modeling inputs that are described in Chapter 3.1 are basically separated into two categories. First category is fixed costs, whereas second category is variable costs.

3.2 Marginal Cost

In economics, marginal cost is the amount of additional cost required to produce one more unit of a product. For each production amount, additional costs are employed. Therefore, fixed costs have no role in marginal cost. From the perspective of electricity generation and pricing of whole system, when supply and demand is in balance in a system, in case of demanding one more unit of energy from demand side, how much additional price is asked by supply side, determines marginal cost.

Mathematically speaking, slope of total cost curve at an amount of quantity gives marginal cost as in Figure 8.

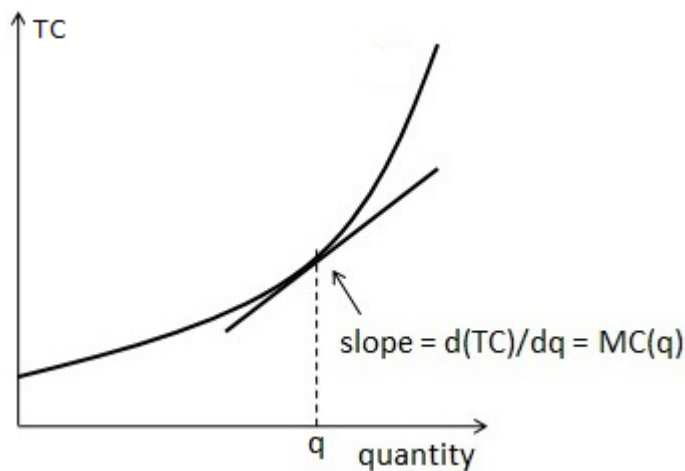

Figure 8 Total Cost vs. Quantity Curve

Marginal cost is an increasing function. That is because, in a balanced system, as there is one more unit demand of energy occurs, energy is taken by lowest cost plant. As long as minimum cost plant can supply more energy to the system, energy is taken by one step higher price of plant. Thus, marginal cost function always increases as in following Figure 9.

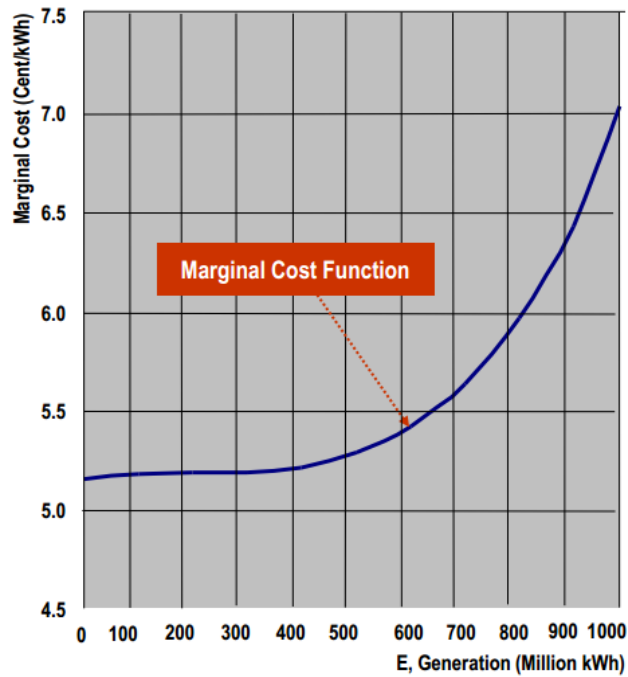

Figure 9 Typical Marginal Cost Curve [13]

However, marginal cost function cannot increase till infinity in x-direction, generation. This is because all plants have maximum generation capacity. Hence, x-direction of marginal cost curve is fixed at some point and marginal cost increase infinity at this point. Figure 9 turns to Figure 10. [22]

In day ahead market, market participants make their bids according to their marginal cost. All generators make their bid with using their own marginal cost curves. Market operator aggregates all curves with the rule of taking the least cost into commitment primarily. Therefore, minimum priced dispatching occurs. Thus, aggregating marginal cost curve is important subject. Marginal costs of two plants are depicted in Figure 11. As observed in Figure 11, marginal curves are discontinuous rather than continuous in real life

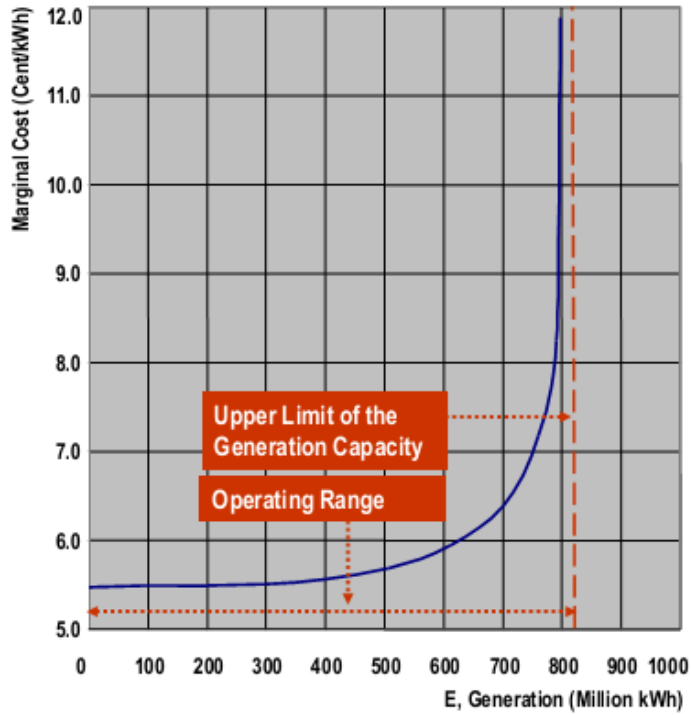

Figure 10 Real Marginal Cost Curve [13]

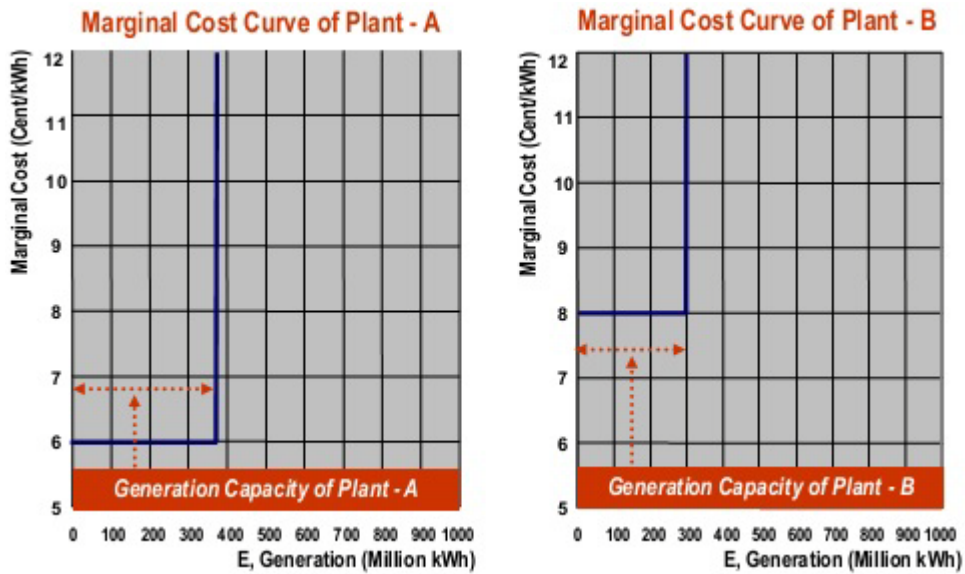

Figure 11 Marginal Cost Curves of Plant A and Plant B [13]

The aggregated curve of Figure 10 curves is shown in Figure 11.

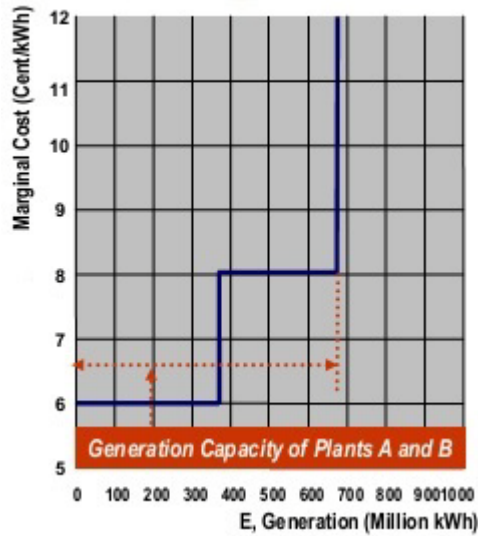

Figure 12 Aggregated Marginal Cost Curves of Plant A and Plant B [13]

As observed in Figure 12, aggregation is based on least cost commitment. For each level amount of power, market operator takes the least marginal cost plant into consideration so that minimum market clearing price occurs. This is the main aim of market.

Economically, marginal cost function determines production cost. The area under marginal cost curve results with total generation cost for a plant for a specified amount of energy generated. Using Figure 10, total generation cost of a plant for producing e_1 quantity of energy in an hour is as follows: [22]

$$Total\ Generation\ Cost = \int_0^{e_1} Marginal\ Cost(E)dE + C$$

where e_1 is the amount of energy to be produced, and C is fixed cost.

Hence;

$$Marginal\ Cost = \frac{d(Total\ Generation\ Cost)}{d(E)}$$

Incremental cost is the amount of generation cost to be incurred to produce energy from e_1 amount to e_2 amount. As a mathematical expression: [22]

$$Incremental\ Cost = \int_{e_1}^{e_2} Marginal\ Cost(E)dE$$

where e_1 is the amount of energy that is produced already. e_2 is the amount of energy to be produced.

In case of demand is greater than the supply in the whole system, a plant may forced to produce its upper production limits, therefore, marginal cost graph tends to increase sharply since additional costs are added to produce huge amounts of energy. Operating plants at limits results with aging so generator company demand more money since marginal cost is increased. In conclusion, in the cases where demand is greater than supply, electricity price increase dramatically.

Before joining to day ahead market, companies need to obtain their marginal cost curves so that they can compete in day ahead market. Since marginal costs imply bids of generator companies at day ahead market, marginal cost plays crucial role in day ahead markets. As a result, market operator can calculate price of day ahead price of electricity as described in Chapter 4, in detail.

3.2.1 Marginal Cost and Average Cost Relationship

Fixed costs do not have affect on marginal cost and average cost and both have unit of TL/MWh. However, marginal cost and average cost should not be confused in cost modeling. Marginal cost is related with the one more extra unit production and take cares only extra unit production, whereas average cost is related with all production and takes the average of whole production.

For low production amounts, marginal cost is smaller than average cost owing to influence of fixed costs. On the other hand, for high production amounts, marginal cost is greater than average cost. Moreover, marginal cost curve intersect average cost curve at minimum of average cost curve as shown in Figure 13 [12].

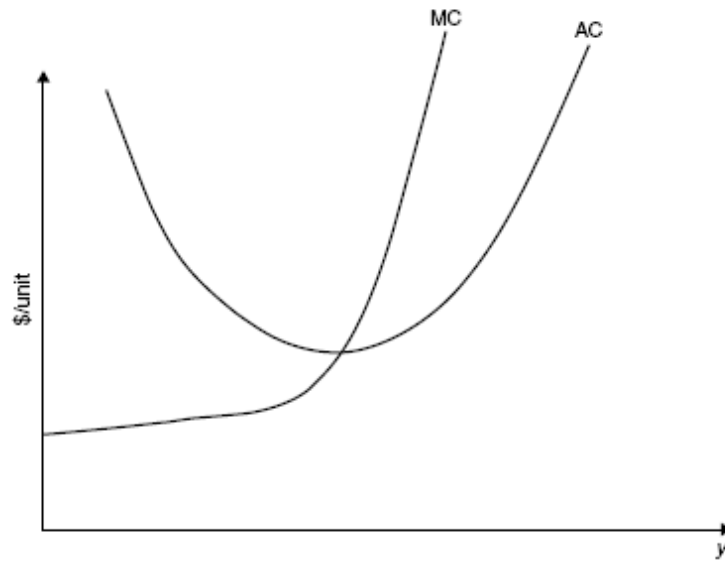

Figure 13 Marginal Cost – Average Cost Relationship [12]

Long run marginal costs and short run marginal costs intersect at point x_1 , where Short run average cost and short run marginal cost curves intersect. Long run marginal cost intersects long run average cost curves at minimum value of long run average cost. As long run marginal cost is smaller than long run average cost; long run average cost decreases. Since average cost decreases, production is said to exhibit economies of scale. Figure 14 shows all Short run average cost, short run marginal cost, long run marginal cost, long run average cost together [12].

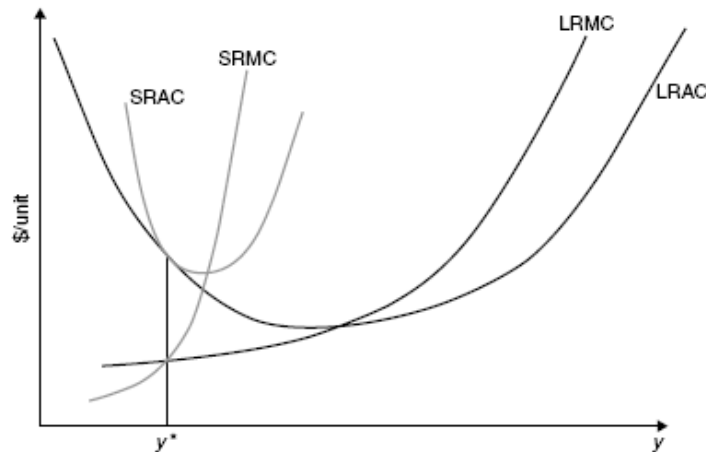

Figure 14 Long and Short Term Marginal Cost – Average Cost Relation [12]

3.3 Short Term Load Forecasting

Short Term Load Forecasting, abbreviated as STLFF, intends to estimate amount of load to be demanded in short term. Short term corresponds to time interval from one hour to one week

in generally. Short term load forecasting is required for appropriate scheduling and operation of whole power system.

Deregulation and privatization of electricity market brings high volatility in electricity prices. This is due to the changes in conditions. In a deregulated energy market, load estimation has to be conducted so that all market participants make their bids in energy market more efficiently. Similarly, system operators utilize short term load forecasting while determining probable transmission congestions and operation of a whole grid. In a day ahead market, amount of expected load to be demanded in whole system in the next day is announced by system operator so that supply side can make their plans and strategy in production of energy and bidding to the market in accordance with the expected load of next day. Supply side can adjust its operation and bidding strategy according to short term load forecasting. Similarly, demand side also can make their own bidding using short term load forecasting. Therefore, for all market participants and system operator, short term load forecasting plays a crucial role economically after opening electricity industry to the market. However, accuracy of short term load forecasting is crucial for market and its participants.

3.3.1 Factors Affecting Short Term Load Forecasting

Time factors, weather factors, price factors and random disturbances affect mainly short term load forecasting accuracy [14].

Time factors consist of seasonal, weekly, daily and holiday effects. In daytime and at night, load patterns change. Similarly, load patterns of summer and winter in daytime are different. Weekdays and weekends have different load duration curves in that industrial demand is higher on weekdays. Holidays affect load curves. In holidays, load tends to decrease.

Weather factors consist of temperature, humid. In winter, heating, in summer, air conditioning loads the system while adjusting temperature. Humidity also affects load patterns in similar way. In more humid areas, load amounts tend to increase.

Price factors become important after electricity market is opened to the market. Since price of electricity is volatile, load patterns are affected due to the price of electricity.

Random disturbances are the disturbances those are incurred by instantaneous load change of large industrial companies in the system. Moreover, some specific events and situations may lead significant load changes in system.

There are manifold numbers of methods employed in short term load forecasting. Regression, time series, pattern recognition, Kalman filters are widely used methods in STLF in the past. Short term load forecast amount and affecting factors have obviously nonlinear character. Moreover, these methods do not represent the nonlinear relationship between load and factors affecting load. In order to take nonlinear relationships into consideration more

efficiently to get more accurate results, alternative methods such as artificial neural network, fuzzy logic are widely used to forecast short term demand forecasting [14]. In the next section, an example regarding artificial neural network is examined.

3.3.2 Artificial Neural Network

Artificial Neural Network is abbreviated as ANN. Artificial neural network utilize historical data. By using historical data related with load demand and factors affecting forecasting, network is created and trained. Hence, forecasting is accomplished. Accuracy of artificial neural network method is directly dependent to the inputs given to the network. When more affecting factors and historical data are inserted to the network as input, accuracy of forecasting increases. Therefore, number of historical data plays a crucial role in artificial neural network while forecasting short term demand. In other words, if we have enough historical data, we can employ an ANN to find the relationships between these factors and load quantity.

By using various kinds of historical data, network is trained. In training session, each and every historical load data in network is correlated with other data by taking other inputs such as historical temperature data and/or historical humidity data into consideration, thus a resultant trained network occurs. Therefore, network gets ready to forecast for the short term [14].

ANN structure is explained in detail in APPENDIX-B.

An example, STLF-DATA.xls is studied at this part of thesis. According to STLF.xls, STLF is applied by using MATLAB ANN Toolbox. In STFL.xls;

First data block is related with amount of load consumed in between 1.1.2012 and 30.12.2012 in an hourly basis.

Second data block is related with actual temperature observed in between 1.1.2012 and 30.12.2012 in an hourly basis.

Third data block is related with actual humidity observed in between 1.1.2012 and 30.12.2012 in an hourly basis.

In the studied example, the first 80% (i.e., between 0%-80%), 10% (i.e., between 80%-90%) and last 10% (i.e., between 90%-100%) of the recordings is utilized for training, validation and test respectively.

Example is given in two different aspects and comparisons. For the first part, only load data and temperature data is taken into consideration, whereas, in second step all load data, temperature and humidity is used as input.

a) Only with temperature; training, validation, test and combined results are obtained as shown in Figure 15:

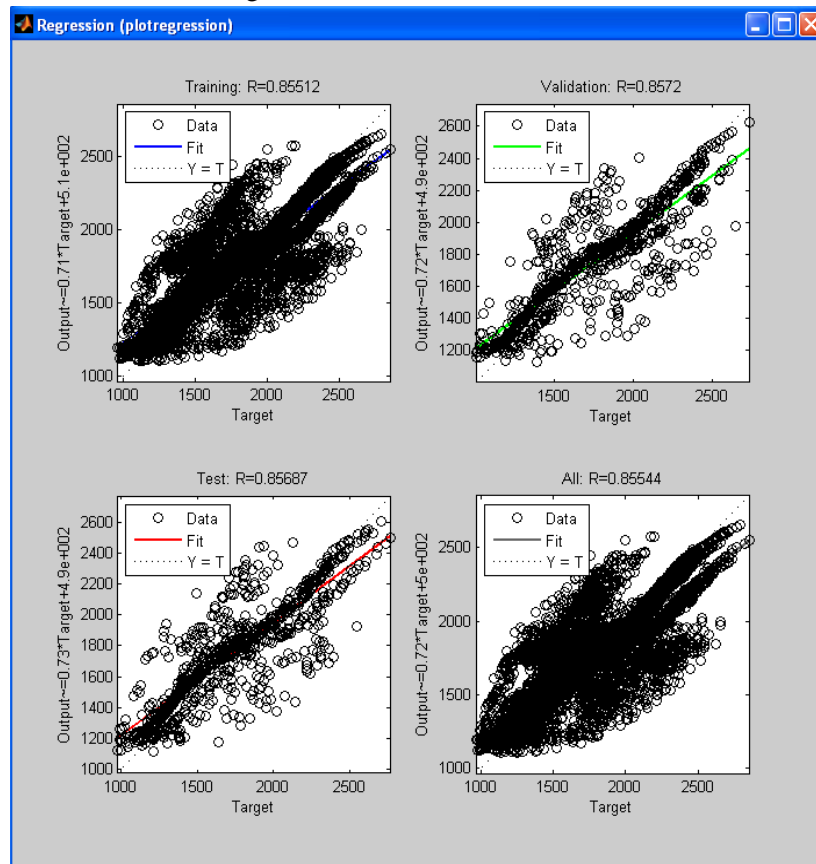

Figure 15 Regression Plot with load and temperature data

It is observed in Figure 15 that;

training regression is 0.85512

validation regression is 0.8572

test regression is 0.85687

combined (all) regression is 0.85544

Expected load curve and historical curve are depicted in Figure 16.

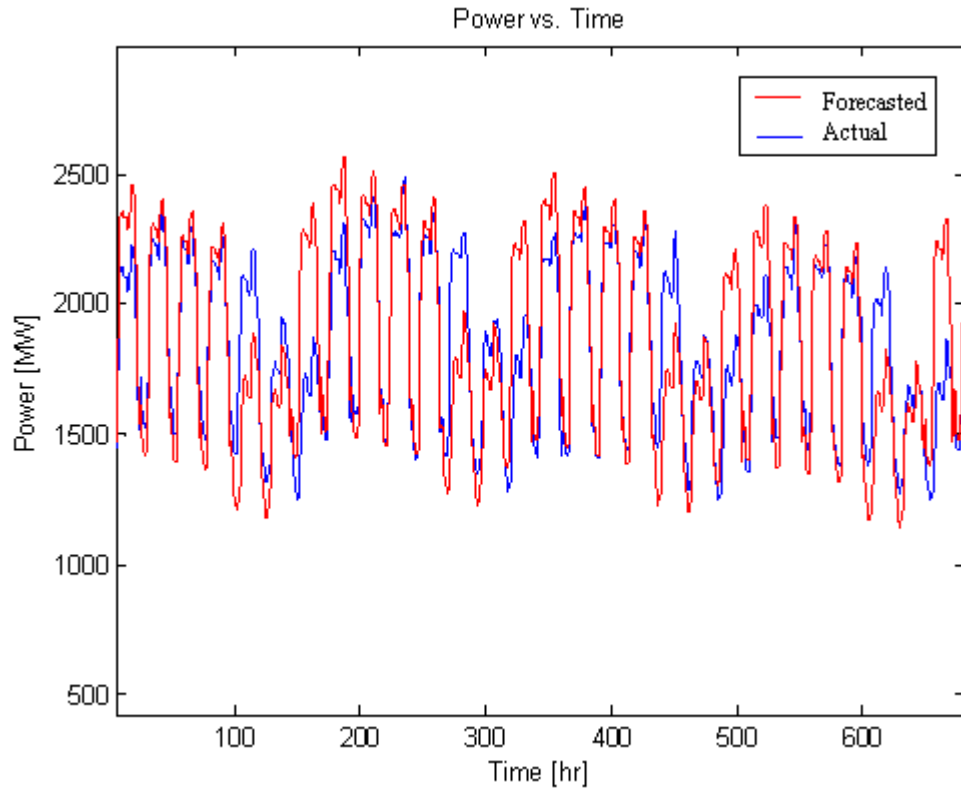

Figure 16 Expected load curve and historical curve

Mean square error of network is: 4.33×10^4 as shown in Figure 17.

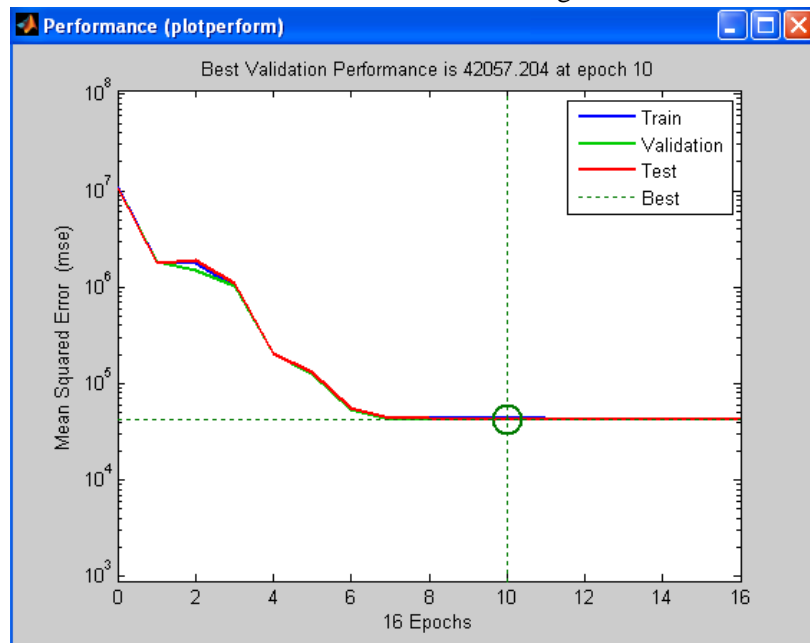

Figure 17 Mean Square Error vs. Epochs

- b) With load, temperature and humidity data ; training, validation, test and combined results are obtained as shown in Figure 18:

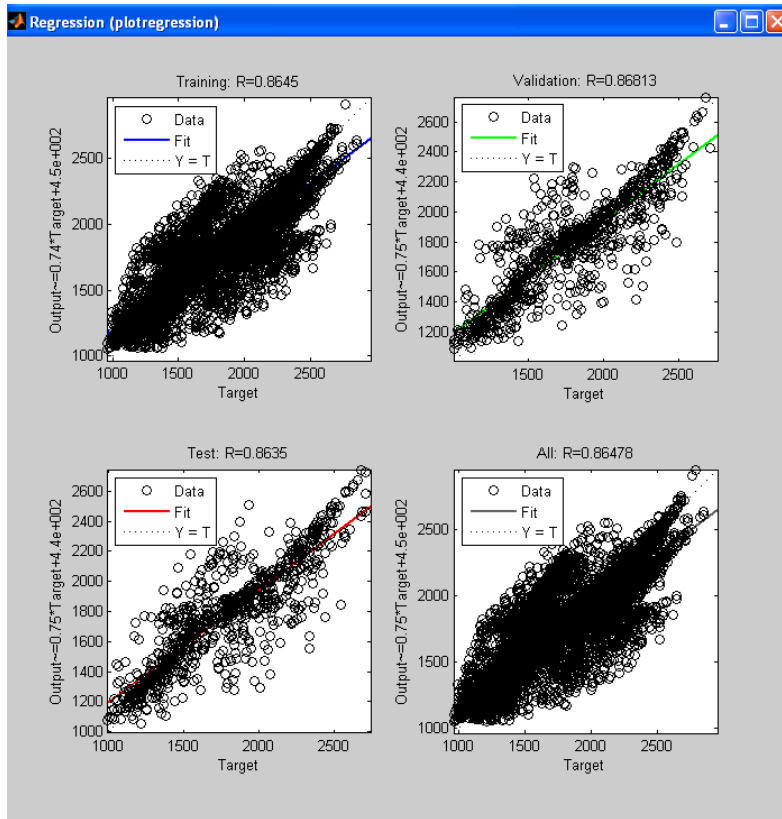

Figure 18 Regression Plot with load, temperature and humidity data

It is observed in Figure 18 that;

- training regression is 0.8645
- validation regression is 0.86813
- test regression is 0.8635
- combined (all) regression is 0.86478

Expected load curve and historical curve are depicted in Figure 19.

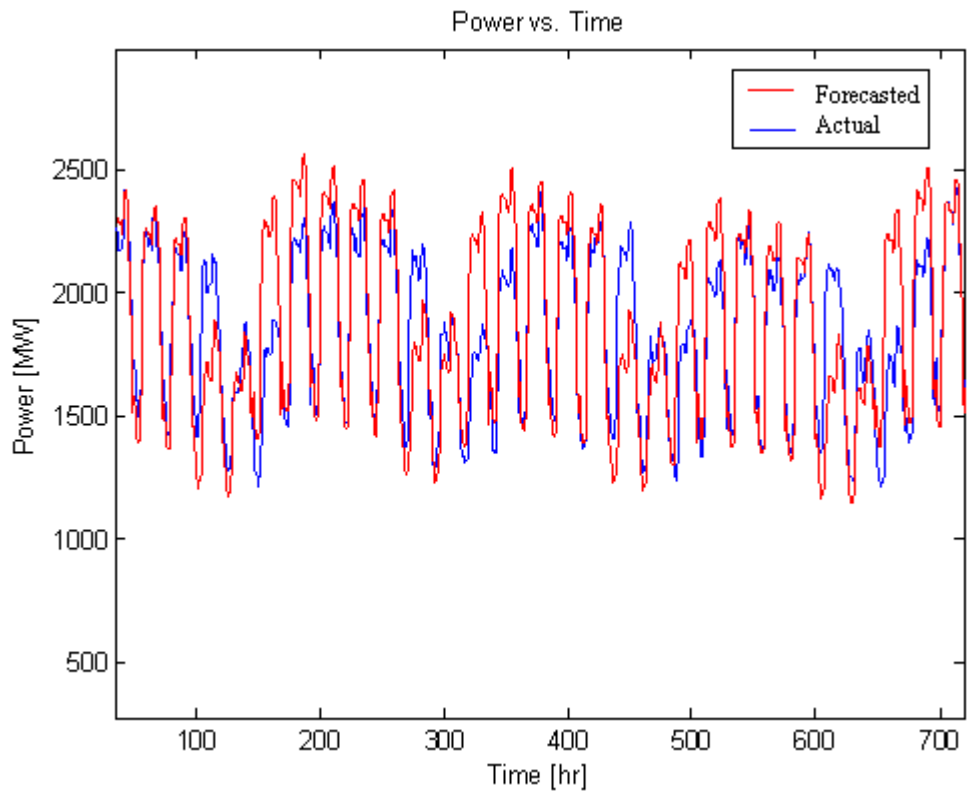

Figure 19 Expected load curve and historical curve

Mean square error of network is: 3.9221×10^4 as shown in Figure 20.

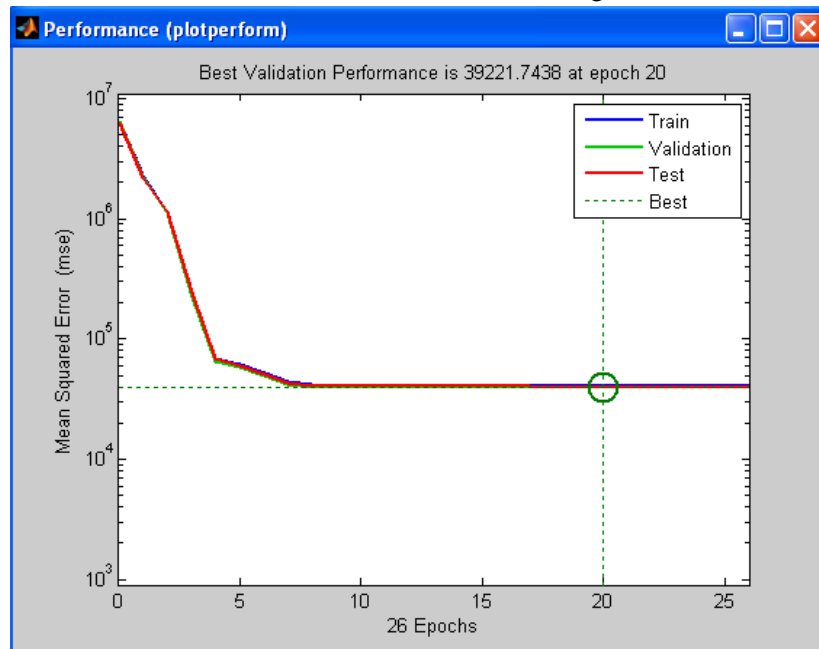

Figure 20 Mean Square Error vs. Epochs

As a comparison, all training, test, validation and combined regression values increased and get closer to 1 after adding an extra input, i.e. humidity. This implies correlation of graphs

increase to 1. Hence, training and forecasting capability of network is improved, so mean square error decreased. As a result, more accurate forecasting is accomplished.

In conclusion, adding extra inputs to the network improve forecasting accuracy. In order to achieve the most accurate forecasting results, various kinds of historical data have to be entered to the artificial neural network.

CHAPTER 4

DAY AHEAD MARKETS AND MODELS

4.1 Structure of Day Ahead Markets

Day ahead Market is the market in which energy trading is completed one day ahead of actual transfer of energy.

Day ahead market has basically two different sides and 2 different operators basically. Sides of the day ahead markets are basically suppliers and demanders. Operators are system operator and market operator. Market operator manages the financial market, whereas system operator cares for feasibility of energy transfer agreements in physical transmission manner. Market operator manages the market according to law and legislations about day ahead market. Laws and legislations include all flow and rules of day ahead market system. The crucial point is that both system operator and market operator must be objective, transparent and at equal distance to all participants. Otherwise, perfect competition is not achieved. In most countries, especially in USA market and UK markets, market operator and system operator are distinct from government. However, in Turkey, both market operator and system operator are under TEİAŞ which is governed by government.

Generator operators calculate their own start-up costs, running costs, shut-down costs and other costs. According to calculations of costs and signed bilateral contracts, generator operators decide to participate or not participate in day ahead market. Energy producers propose energy to this market based on their capacity for producing energy for a specific hour period on the next day. Buyers and sellers bid quantity-price couples for each hour for the next day. Bided quantity-price pair demonstrates that participant has willingness to buy or sell bided quantity at bided price. Details of bids are examined in Chapter 4.6.2.

After submission of bids by market participants; matching of bids and dispatching of electricity process is accomplished by market operator. Since electricity is not a stored commodity, at each and every second system must have supply demand balance. Market operator makes dispatching by balancing supply and demand; moreover, prices incurred on each market participants are calculated according to model of day ahead market. Day ahead markets have mainly two models throughout the world. These are auction trading model and continuous trading model. In Turkey and most European countries utilize Uniform Price model, whereas some energy regions in USA and some European countries such as United Kingdom, Germany and France, utilize Continuous Trading method which does not result with uniform price of electricity in market. Some models emerge unique electricity price after day ahead market process, on the other hand, some models emerge different prices for

contracts in day ahead market. Each of these models has different pricing methods, advantages and disadvantages are explained in Chapter 4.5, in detail.

Another important part of day ahead market is the infrastructure of day ahead market system. Market participants make their bids, follow results, and make objections through software programs. Therefore, reliability and security of software is very important. Figure 21 illustrates a simple figure about structure of day ahead market.

Participating day ahead market is not mandatory everywhere in the world which employs day ahead market. This is because mostly energy is traded via bilateral contracts and day ahead market is second chance for buying or selling energy.

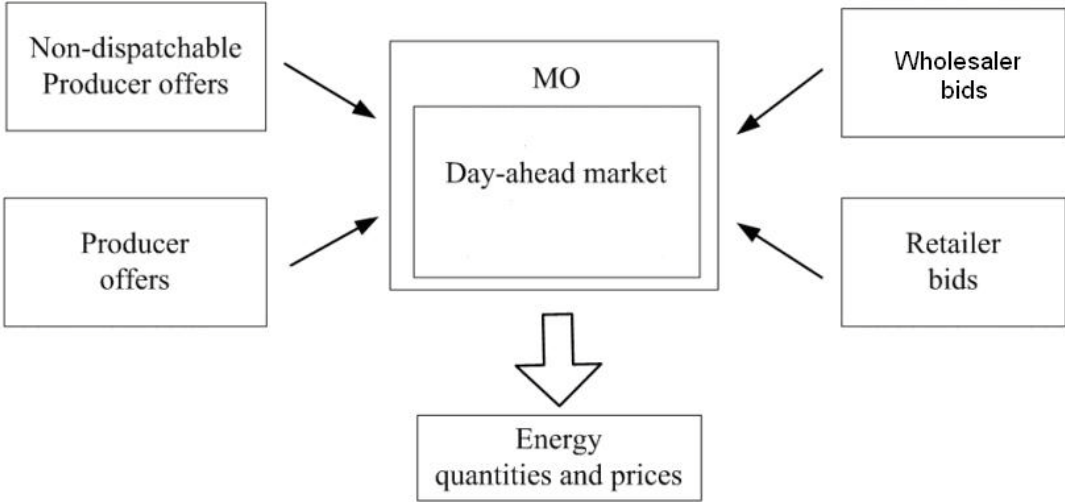

Figure 21 Structure of day ahead market

4.2 Aim of Day Ahead Markets

The aims of Day Ahead Market can be listed in short as follows:

- Balancing the production and/or consumption necessities of market participants. Due to the bilateral contracts signed by market participants, market participants may have electricity scarcity or surplus. Thus, Day Ahead Market gives another chance for market participants to balance their portfolio. Since market participants balance their own portfolio, system is balanced as a whole. Therefore, plant commitment schedule is determined.
- Determining the Market Clearing Price of Electricity.
- Determining reference price of electricity. Reference price is useful for long term contracts and short term bids. By means of day ahead market price, market participants can aware at how much price they can sign long term bilateral contracts. Similarly, market participants have chance at which price they can bid in balancing and real time markets.

- Providing a balanced system between supply and demand to the System Operator. As a result, scarcity of electricity in consumer side is overcome. Reliable electricity system is achieved.
- Providing a restriction management to the System Operator due to the transmission congestions. Restriction management is especially provided in day ahead markets which apply market splitting. Market splitting dispatches the whole system by caring transmission line capacities and balancing is achieved perfectly. Market splitting is explained in Chapter 6 examples in detail.
- Providing an extra opportunity for market participants for trading electricity. Since electricity trading is based on bilateral contracts, market participants have second chances to trade if they could not sign bilateral contract. Even they signed a contract, by trading in day ahead market, they find chance to balance their portfolio and obeying bilateral contract as well.

Day Ahead Market is mainly a balancing mechanism between supply and demand amounts of electricity energy in an hourly basis, in which trading is completed one day ahead of actual transfer of electricity energy. Both supply and demand sides propose their own bids and Market Operator results matching due to given proposals of both suppliers and consumers. This matching process assures least cost and more efficient market solution.

In a deregulated generation and wholesale and/or retail sales phases of electricity market, Day Ahead Market requires 2 sides. These sides are mainly supply side and demand side. Supply side includes supplier of Electrical Energy, i.e. producers. On the other hand, demand side is consumers of Electrical Energy. Detailed explanation of sides of Day Ahead Market is explained in Chapter 4.3 in detail.

These 2 sides, buyers and sellers, trade Electricity mainly via Bilateral Contracts. In a Bilateral Contract, one buyer and one seller reach an agreement on a certain amount of Energy in a period of time. That means, seller is ready to produce the specified amount of energy in an agreed time interval. In the same manner, buyer is ready to buy certain amount of energy in an agreed time interval. However, Bilateral Contracts cannot fully solve portfolio management problems.

All producers desire to use their full capacity and sell them all so that producers can make more profit. Day Ahead Market is a chance for a producer company to sell its remaining energy. A seller should calculate the costs of its generation with fewer errors. Generation costs include, start up costs, running costs, shut down costs and other costs as detailed in Chapter 3. According to calculations, a seller can sign appropriate bilateral contract with buyers for long terms. Of course there is no obligation for signing bilateral contract. If seller regards that bilateral contract is not so much profitable and reasonable as desired, a seller can wait for Day Ahead Market for trading their capacity in a short term. Moreover, even if a seller has signed a bilateral contract; a seller can still have capacity to produce electricity outside of signed bilateral contract. In such a case, day ahead market gives opportunity to

this seller for more trading. In addition, a seller company may participate in day ahead market and can balance its portfolio even if it has signed bilateral contract. This seller company can buy electricity via day ahead market and give this amount according to the pre signed contract, if day ahead market price is feasible. Similarly, a seller may have production problems and do not have chance to meet bilateral contract. In such a case, day ahead market helps seller to manage its portfolio and to meet pre signed bilateral contract. Thus, Day Ahead Market is a good chance for trading efficiently and trading the rest of Electricity Energy for sellers.

Buyers sign bilateral contracts with sellers. Buyers can sign a long term bilateral contract with producers. When buyers do not sign and agree on a reasonable and profitable contract with a producer, buyers have opportunity to fulfill requirement of its forecasted electricity energy via attending Day Ahead Market. Hence, buyer companies, i.e. wholesale and retail companies, have chance to balance their own portfolio.

Both buyer and seller are caring their own profits and losses. Seller and buyer should calculate these loss and profits carefully and they should have accurate forecasting for their supply and demand of electrical energy.

From the view of buyers, a buyer should estimate the required electrical energy in a long term accurately so that buyer should not make too much loss upon its highly estimated error. Upon forecasted long term consumption, a buyer search for a long term bilateral contract with a seller. When a buyer finds a profitable agreement with a seller, buyer signs bilateral contract with a seller. However, a buyer may not be able to purchase all amount of desired energy or a buyer may not be able to sign a bilateral contract. Another possibility is that, buyer can have more demand in short term because of error estimation and extra demand. In such cases, Day Ahead Market helps buyers to trade and purchase electricity via market. A buyer has no obligation as sellers to participate in Day Ahead Market auctions and no obligation for presenting bids.

Since each Day Ahead Market sides are free to participate in and free to make bids as they wish, Day Ahead Market makes balance profit for both buyers and sellers. Day Ahead Market helps bilateral contracts so that sides can trade electricity if they did not find any chance in Bilateral Trading.

Thus, Day Ahead Market gives opportunity to both buyers and sellers to make more profit and to use their full demand and supply capacity with highest efficiency. This is portfolio balancing, management of each market attendant. Since they are profit based private companies, all sides win in such a system. There is no pure winner or loser in a privatized electricity sale market via Day Ahead Market. As a result of portfolio balancing, system is also balanced physically and neither surplus nor scarcity occurs in whole system. Therefore, plant commitment schedule is determined. According to the plant commitment schedule, plant commitment sequence is determined. This is operation plans of plants in whole system. Hence, how long and when each plant will work is determined.

As a result of Day Ahead Market, system has more balance and reliability in general. That is because bilateral contracts are signed according to agreements of a buyer and seller. In such a bilateral agreement, sides of agreements do not care system balancing. By attending Day Ahead Market, system operator have chance to gather all information related to lack of energy. Thus, as a result of submitted bids, market operator optimizes matching solution in order to obtain most efficient system. Since matching process is achieved by considering efficiency for the prices, all sides intersect in a point. After having matched the market, system obtains high balance electrically. There remains less lacks in balance. In addition to balancing opportunities, day ahead market auction process occurs one electricity price in each period of hour. Therefore, this process determines market clearing price of electricity.

However, bilateral contracts that are signed between sellers and buyers need to have reference price. Otherwise, sides of contract will not aware which price is feasible or not. Thus, day ahead market helps market participants for determining price of trading via bilateral contract. This is regarded as reference price. Knowing about the reference prices helps market participants in bidding for long term contracts.

Providing a restriction management to the System Operator due to the congestions is another crucial aim of day ahead markets. Restriction management is especially achieved when market splitting is applied in day ahead market. Market splitting indicates dividing whole system into regions which results with different market prices of electricity. Different market prices means transmission line capacities between regions are taken into consideration while balancing of supply and demand by market operator. Hence, transmission congestions are managed and system is assured to be reliable. Market splitting is explained in Chapter 6 with examples in detail.

4.3 Sides of Day Ahead Markets

Day Ahead Market requires mainly 2 different sides. One of these sides is supply side and the other one is demand side. Supply sides submit their production capacity basically. Moreover, supply sides are able to purchase energy from other producers and can sell it to the market which is left from bilateral contracts. Demand sides purchase their required amount of energy from bilateral contracts. However, as there is lack of required energy, demand side should participate in Market so that it can fulfill their required energy by means of Day Ahead Market.

In Day Ahead Market structure, a company can be both supplier and demander. There is no obligation for just being one side. One company cannot be producer, but it can sell energy to the market which is purchased by Bilateral Contract. All depends on licensing and regulations of each system where applied.

In Turkey, according to the Balancing and Settlement Regulations, Article 10, market participants as juristic person are listed as follows [15]:

- a- Owner of Production License
- b- Owner of Auto producer License
- c- Owner of Auto producer Group License
- d- Owner of Wholesaler License
- e- Owner of Retail Sale License
- f- Owner of Organized Industry Region Production License
- g- Owner of Distribution License

The main requirement while joining market according to the rules is that market participants should not give damage to the market and/or system operation.

- a- Owner of Production License: Production License is given to juristic person which can produce electricity and sells the electricity to the market which is produced by itself. This group excludes auto producers and auto producer groups.
- b- Owner of Auto producer License: Auto producer License is given to juristic person which produce its own consumed amount of energy by itself.
- c- Owner of Auto producer Group License: Auto producer Group License is given to juristic person which produce all of its partners consumed amount of energy by itself.
- d- Owner of Wholesaler License: Wholesaler License is given to juristic person which can sell whole Electrical Energy and/or Electrical Capacity, export Electrical Energy and/or Electrical Capacity, import Electrical Energy and/or Electrical Capacity, sell Electrical Energy and/or Electrical Capacity to free consumers and trading Electrical Energy and/or Electrical Capacity.
- e- Owner of Retail Sale License: Retail Sale License is given to juristic person who can sell Electrical Energy and/or Electrical Capacity as retail to the consumers. Such consumers should not be connected to the transmission system directly.
- f- Owner of Organized Industry Region Production License: Organized Industry Region Production License is given to juristic person which can produces and trade Electrical Energy inside an approved region according to law of Organized Industry Region, law number 4562. Organized Industry Region Production juristic person are approved by competent authority.
- g- Owner of Distribution License: Distribution License is given to juristic person which can distribute electricity in a determined area. Distribution terminology contains the distribution operation in which Electricity Energy is distributed via grids which are less than and equal to 36kV.

4.4 Supply-Demand Balance

Day Ahead Market is the market in which the trading of electricity is completed one day ahead of actual transfer date. As a result of this process, electricity price is determined and dispatching of plants is completed. In a privatized generation and sales phases of modern electricity market, bilateral contracts plays important role while dispatching of electricity. By means of bilateral contracts and day ahead markets, system operator and market operator achieve supply demand balance. Otherwise, there can be scarcity or surplus for electricity. Since electricity is not a storable commodity, produced energy can be in vain and market losses can emerge. Scarcity is also dangerous in that Electricity price can increase abnormally. Therefore, supply and balance should be in balance in system at any time. Supply-Demand Balance is achieved by Market Operator according to bids of suppliers and demanders.

System Operator has the duty of forecasting demand of system for the next day in an hourly basis. Forecasted demand throw light on making decision in bidding strategies and hedging strategies for market participants. Buyer and seller companies also make estimations about the supply, demand and marginal price of electricity. According to their estimations, cost calculations and bilateral contracts, they conclude their bidding.

After collecting submitted buying and selling bids, market operator need to dispatch electricity economically in most efficient way. Hence, market operator starts dispatching of sellers from the lowest bid to the highest bid. Hence, minimum market price of electricity occurs in market. Bids of sellers indicate marginal costs of sellers; although these bids may not present actual marginal costs of market participants. This is related with stiffness of market. The more stiff market brings more realistic bids into the market.

Each and every submitted selling bids to day ahead market for the specific 1 hour time interval is listed increasingly. Increasing listing is price based and starting from the lowest price and its corresponding quantity value; listing is done till reaching highest price and its corresponding quantity value. These values are inserted to the supply demand curve by using linear interpolation method as supply graph. All selling bids are aggregated in one graph after obtaining individual supply graphs.

Each and every submitted buying bids to day ahead market for the specific 1 hour time interval is listed decreasingly. Decreasing listing is price based and starting from the highest price and its corresponding quantity value; listing is done till reaching lowest price and its corresponding quantity value. These values are inserted to the supply demand curve by using linear interpolation method as demand graph. All buying bids are aggregated in one graph after obtaining individual supply graphs.

Gathering supply and demand curves in one graph reveals an intersection of supply demand point for a specific 1 hour period. This is the point where supplied and demanded power quantities are equal, which means there is neither shortage nor surplus of electricity in whole

system. So system supply and demand is in balance and market is at equilibrium point economically.

However, if supply and demand curves do not intersect with each other, supply demand balance is accomplished by moving demand curve to the supply curve in which all buyers are affected equally in mathematically. Supply curve is fixed at this case. Thus, supply demand balance is obtained. As an alternative method, market operator may ask market participants to submit bids again and repeat the auction and calculations in order to intersect supply and demand curves so that system is in balance.

In cases which supply and demand curves intersects more than a point, such as a straight line, system balance is obtained by taking the midpoint of straight line. Thus, supply demand balance is acquired.

The process of supply demand balance starts with calculating the intersection point of supply and demand curve as described above for each hour assuming the whole system as 1 region without having transmission line limits. No matter how many regions exist in system and no matter how much capacity of transmission grids have, system is said to be one, and market operator calculates only intersection point as explained above ignoring the regions and transmission constraints. Supply demand curve intersection point without regarding regions is called Non-Restricted Market Exchange Price, abbreviated as KPTF. However, if there is more than 1 region in whole system, regional prices and new supply demand mechanism is conducted for balancing. Splitting a whole country into regions is called Market Splitting. For markets which apply Market Splitting, according to the calculation of KPTF by ignoring transmission constraints; if the difference between supply and demand quantities of power is lower and equal to system transmission constraint on transmission line, Restricted Market Exchange Price (abbreviated as NPTF) is equal to the KPTF. That means the region which has energy surplus can supply to the region which has energy deficiency. Hence, supply and demand balance is acquired and there occurs only one price in system, KPTF, since all regions have NPTF equal to the KPTF [15].

Regions are connected to each other via constrained limit of transmission lines; therefore, from one region to another region, the required energy may not be transferred fully because of transmission constraints on the lines between regions. According to the calculation of KPTF by ignoring regions; if the difference between supply and demand quantities of power is higher than transmission line constraint, supply demand balance is completed as follows. KPTF of region which has energy surplus is decreased till transmission capacity is not exceeded. Similarly, KPTF of region which has energy scarcity is increased till transmission capacity is not exceeded. Thus, each region has its own NPTF. At this case, NPTF of region which has energy surplus is equal to the KPTF minus the amount of decreasing. NPTF of region which has energy scarcity is equal to the KPTF plus the amount of decreasing. Thus, all regions have different prices and supply demand balance is obtained at the end of transmission processes among regions. Therefore, supply demand balance reveals both NPTF and KPTF. NPTF and KPTF are calculated for each hour as described above. As a

result of Market Splitting, transmission congestion is managed and energy is spread all over country efficiently. Moreover, if transmission line limits are taken into consideration while supply demand balancing, different regional prices occur in system.

However, in cases where Market Splitting is not applied, such as in Turkish Day Ahead Market Structure, only KPTF occurs in system. There is no NPTF, regional pricing. This results with non handling of transmission congestion. It is because market operator dispatches whole system by not taking the transmission line limits into consideration. Dispatch is done by regarding whole system as one unit. Yet, transmission lines have still limit. So according to results of KPTF, some regions may encounter energy scarcity whereas some regions may have energy surplus. Such situations occurred in Mediterranean region in the past in summer season because of high demands. If Turkish Day Ahead Market System was based on Market Splitting, there would not be energy scarcity [15].

There is an example illustrated below regarding supply demand balance in day ahead market auction structure for a 1 hour period of time interval without market splitting. However, in Chapter 6, more detailed example is given with explanations of each step for day ahead market calculations.

Table 1 Illustration of Bids of market participants

Price, (TL/MWh)	0	100	110	120	130	140	150	160	300	500
Participant A, (Seller)	-30	-30	-30	-30	-30	-30	-30	-30	-30	-30
Quantity (MW)										
Participant B, (Buyer and Seller)	400	400	250	0	0	0	-100	-130	-170	-170
Quantity (MW)										
Participant C, (Buyer and Seller)	80	80	80	80	30	30	-30	-30	-30	-30
Quantity (MW)										
Participant D, (Buyer)	90	90	90	90	90	90	60	30	30	30
Quantity (MW)										
Participant E, (Buyer)	120	120	100	100	100	100	100	100	100	100
Quantity (MW)										
Total Buying Quantity (MW)	690	690	520	270	220	220	160	130	130	130
Total Selling Quantity (MW)	-30	-30	-30	-30	-30	-30	-160	-190	-230	-230
Total Quantity (MW)	660	660	490	240	190	190	0	-60	-100	-130

Table 1 illustrates the bids of 5 participants to the day ahead market. All prices are listed from lowest to the highest price, noting that - denotes bids for selling, conversely + denotes bids for buying electricity. Therefore, each participant has its own supply and/or demand curve. Without drawing supply demand curve for each participant, prices can be listed as in Table 1. For each and every price value, quantities of power are added to each other. At the point where 0 occurs, clarifies buying quantity is equal to selling quantity, balance point. Combined supply demand curve using interpolation method is depicted in Figure 22. For Table 1, day ahead market price (abbreviated as SGOF) is 150 TL/MWh at a quantity of 160 MW. 160 MW defines that, 160 MWh energy has to be produced as well as consumed at bided time interval in whole system. For bids of Table 1, resultant day ahead market dispatching is as follows;

- Participant A will sell 30 MWh energy
- Participant B will sell 100 MWh energy
- Participant C will sell 30 MWh energy
- Participant D will buy 60 MWh energy
- Participant E will buy 100 MWh energy

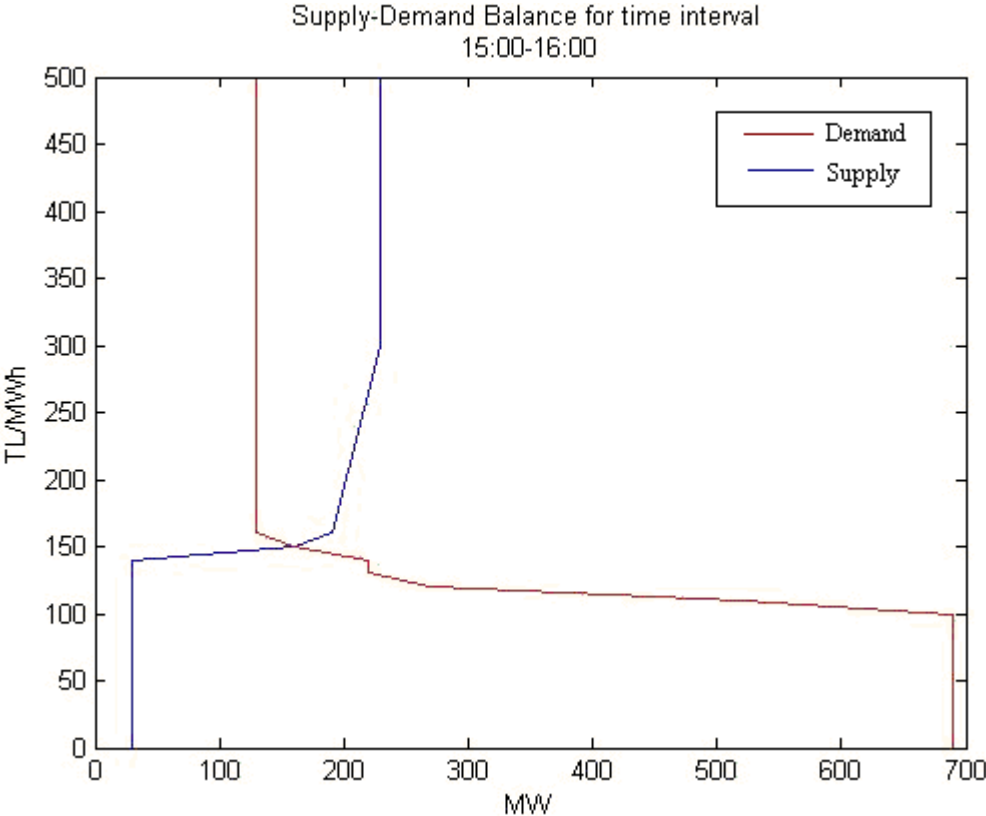

Figure 22 Supply Demand Balance example

After obtaining System Day Ahead Price, abbreviated as SGOF, the amount of prices to be paid and received is calculated in order to obtain the settlement of day ahead balancing operations.

From sellers' point of view and single hour bids, the amount of price that is paid to the seller, abbreviated as SST, according to the balancing activities is computed as follows:

$$SST_{t,p,s} = \sum_{u=1}^a \left(\sum_{r=1}^n (SSF_{t,p,s,u,r} \times SSM_{t,p,s,u,r}) \right) \quad [15]$$

For this calculation, System Selling Quantity Amount, abbreviated as SSM, is the amount of quantity of power that has to be supplied to the system according to balancing activities in MW. SSF is the abbreviation of System Sales Prices in TL/MWh. System Sales Prices is calculated while taking each bids submitted to the market into consideration. Since SGOF is determined, the following algorithm is applied to obtain System Sales Prices.

If $SSTF_{t,p,u,r} \leq SGOF_{t,u}$, then $SSF_{t,p,u,r} = SGOF_{t,u}$
 If $SSTF_{t,p,u,r} > SGOF_{t,u}$, then $SSF_{t,p,u,r} = SSTF_{t,p,u,r}$

SSTF denotes System Selling Bid Price in TL which is bided by seller to the day ahead market.

In case of block selling bids, the amount of price that is paid to the seller according to the balancing activities is computed as follows:

$$OSGÖF_{t,r} = \frac{\sum_{u=a}^b SGÖF_{t,u}}{(b-a)} \quad \text{and } u=[a,b] \quad [15]$$

For this calculation, OSGOF denotes System Day Ahead Price. b denotes block bid finishing time. a denotes block bid starting time. After obtaining OSGOF, SSF is calculated as follows:

$$\text{If } SSTF_{t,p,r} \leq OSGÖF_{t,r} \text{ then } SSF_{t,p,r} = OSGÖF_{t,r} \quad [15]$$

$$\text{If } SSTF_{t,p,r} > OSGÖF_{t,r} \text{ then } SSF_{t,p,r} = SSTF_{t,p,r} \quad [15]$$

From buyers' point of view and single hour bids, the amount of price that is paid by the buyer, abbreviated as SAT, according to the balancing activities is computed as follows:

$$SAT_{t,p,s} = \sum_{u=1}^a \left(\sum_{r=1}^n (SAF_{t,p,s,u,r} \times SAM_{t,p,s,u,r}) \right) \quad [15]$$

For this calculation, System Buying Quantity Amount, abbreviated as SAM, is the amount of quantity of power that has to be received from the system according to balancing activities in MW. SAF is the abbreviation of System Buying Prices in TL/MWh. System Buying Prices is calculated while taking each bids submitted to the market into consideration. Since SGOF is determined, the following algorithm is applied to obtain System Buying Prices.

$$\text{if } \text{SATF}_{t,p,u,r} \geq \text{SGOF}_{t,u} , \text{ then } \text{SAF}_{t,p,u,r} = \text{SGOF}_{t,u} \quad [15]$$

$$\text{if } \text{SATF}_{t,p,u,r} < \text{SGOF}_{t,u} , \text{ then } \text{SAF}_{t,p,u,r} = \text{SATF}_{t,p,u,r} \quad [15]$$

SATF denotes System Buying Bid Price in TL which is bided by buyer to the day ahead market.

In case of block buying bids, the amount of price that is paid by buyer according to the balancing activities is computed as follows:

$$\text{OSGÖF}_{t,r} = \frac{\sum_{u=a}^b \text{SGÖF}_{t,u}}{(b-a)} \quad \text{and } u = [a,b) \quad [15]$$

For this calculation, OSGÖF denotes System Day Ahead Price. b denotes block bid finishing time. a denotes block bid starting time. After obtaining OSGÖF, SSF is calculated as follows:

$$\text{If } \text{SATF}_{t,p,u,r} \leq \text{OSGÖF}_{t,r} \text{ then } \text{SAF}_{t,p,u,r} = \text{SATF}_{t,p,r} \quad [15]$$

$$\text{If } \text{SATF}_{t,p,u,r} > \text{OSGÖF}_{t,r} \text{ then } \text{SAF}_{t,p,u,r} = \text{OSGÖF}_{t,r} \quad [15]$$

4.5 Models of Day Ahead Markets in the World

The day ahead market basically is determination of hourly market prices of electricity and dispatching 1 day prior to the actual transfer of energy. Under this definition, day ahead market is applied in different forms with nuances at all over the world which prevails day ahead market.

Day ahead markets have basically 2 different models. Firstly and the most common applied model is the auction trading. However, as in some markets of USA and in Europe, continuous trading method is also operated together with auction trading. This chapter describes the both day ahead market models by examining advantages and disadvantages of both methods of day ahead markets.

4.5.1 Auction Trading

Auction trading is the simplest method of Day Ahead Markets. Auction trading is based on submitting bids of market participants to the market operator without having a chance of changing the order after submission deadline. Therefore, auction trading can be regarded as one round trading. There is no feedback mechanism so that bidders can make alterations on their bid strategies while taking market conditions, prices into consideration. Auction Trading is used in Nord Pool (Scandinavian countries), EPEX (Germany), EPEX (France), APX Power NL (Netherlands), BelPEX (Belgium), GME (Italy), APX Power UK (United Kingdom), N2EX (United Kingdom), EXAA (Austria), OTE (Czech Republic), TGE (Poland), OMEL (Spain), IEX (India), California ISO (USA).

Price determination of Auction Trading method has also 2 different ways. First way is Market Clearing Price (Uniform Price), while second way is Pay As Bid method.

4.5.1.1 Uniform Price (Market Clearing Price)

Market Clearing Price is the most common method of Auction Trading while determining price of day ahead electricity. All submitted price-quantity pairs related with both supply and demand bids are gathered in one supply-demand curve. As a result of aggregation of bids in 2 curves, intersection point of curves gives the Market Clearing Price of electricity and all transactions are completed according to 1 unique price. Figure 23 depicts supply demand curve of a fundamental auction trading.

In Turkey, Uniform Price Model of auction trading in day ahead market is applied. Not only Turkey but also Nord Pool (Scandinavian countries), APX Power NL (Netherlands), BelPEX (Belgium), GME (Italy), APX Power UK (United Kingdom), N2EX (United Kingdom), EXAA (Austria), OTE (Czech Republic), TGE (Poland), OMEL (Spain), IEX (India) and most regions of USA also applies Uniform Pricing method.

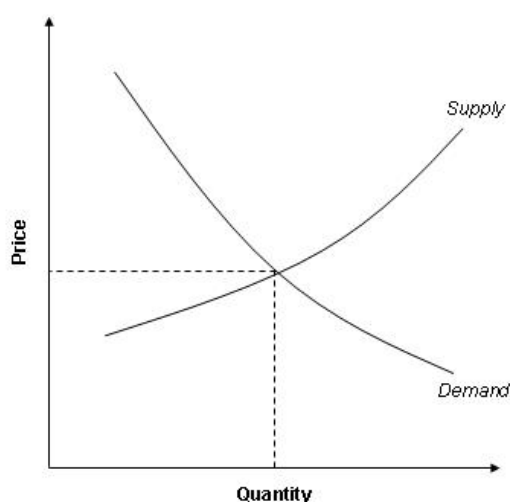

Figure 23 Typical Supply Demand Curve

Advantages of Uniform Price model of Auction Trading can be listed as follows [16]:

- Process of Uniform Price Model is easy to be followed and to be applied
- Uniform Price Model gives accurate information for both short term and long term market and physical efficiency.
- Uniform Price Model displays reference unique price for another markets
- Uniform Price Model causes to productive efficiency

On the contrary to the advantages of Uniform Price, this method may have some disadvantageous parts. If there is not enough competition in the market from suppliers' side, limited amount of suppliers can increase the Market Clearing Price of electricity by decreasing their capacity. Such suppliers can either demand for higher prices than the actual forecasted market clearing price, or may not bid to the market their full capacity. Both of these two strategies of suppliers may lead to increasing of electricity price. However, as the market becomes more competitive, stiff; prices will settle to the actual point as in all other economical commodities.

4.5.1.2 Pay As Bid

Second methodology for auction trading is Pay As Bid method. As a type of auction, both suppliers and demanders make their own bids in day ahead market. The difference for Pay As Bid model is that, there is no fixed unique price for electricity. Instead of determining a unique price, suppliers, who win auction, receive the amount of price that it offered primarily to the day ahead market. Pay as Bid model has been used in UK, but nowadays it is not used.

Pay As Bid method is primarily asked because of decreasing the marginal cost price. By using Pay As Bid strategy, consumer companies wish to decrease suppliers' over profits which can occur as result of Unit Price Model. However, if a supplier company makes forecasting and bids for over prices, price of electricity will again increase. A supplier company can forecast the Uniform Price of electricity; as a result, it can bid for higher prices to maximize its profits. It does not need to calculate and make optimized bid regarding its costs. Therefore, market can be inefficient. Pay As Bid method has more tendency for some sides to have much unfair profits, especially for the supplier side [16].

4.5.1.3 Comparison between Uniform Price Auction vs. Pay As Bid Auction

Figure 24 illustrates an example how supplier can make more profit and how Uniform Price Auction is more transparent in Auction Trading method.

In both graphs of Figure 24, there are 6 suppliers, from A to F, wish to attend day ahead market. And both demand curves are depicted in red color and demand curves are the same. Blue sections of the graphs shows supplier's actual cost as well as the price bided into day ahead market. Since suppliers make bids to market by considering their marginal costs, the left graph of Figure 24 shows transparent bids and costs, that is Uniform Price auction. On

the contrary, in the Pay As Bid auction figure in the right side of Figure 24, seller companies bid higher than their actual costs. This is because in Pay As Bid auctions, sellers receive the amount of price as they bid. Therefore, all seller companies try to increase their bids. This is because the amount of price will be paid to companies according to their amount of their bids. As a result, electricity price increase undoubtedly, taking an advantage to the suppliers to obtain more profit.

As depicted in Figure 24, company A forecasts the price of electricity, so it makes much higher bid for the electricity. Yellow regions show that at how much price companies make bids more than they deserved. However, if uniform price auction is used, since only one electricity price occurs in market, market participants have more tendency to bid as their marginal cost levels because market operator start dispatching from minimum price.

As a result, Uniform Price auction is more transparent and more efficient economical solution in Auction Trading method of day ahead markets.

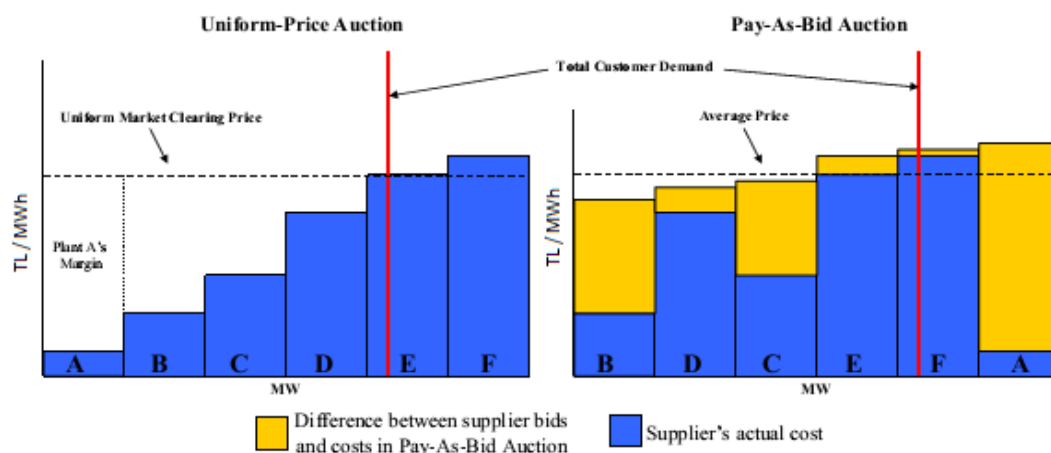

Figure 24 Uniform Price Auction and Pay As Bid Auction

4.5.2 Continuous Trading

As described in part 3.5.1, auction trading do not allow market participants to change their bids after deadline of submissions of orders. Main difference between auction trading and continuous trading emerge at this point. Continuous trading brings more flexibility to market participants so that market participants can alter their bids after submission of their bids according to the situation of prices and quantities of power since order book is visible to all participants. Changes can be done for both price and quantity of power. This gives chance for traders to make more profit and more portfolio management [16].

Continuous Trading auctions are employed with traditional Auction Trading. As an illustration, EEX in Germany, EPEX in France, BelPEX in Belgium, APX Power UK in United Kingdom, N2EX in United Kingdom, and California ISO in USA employs Continuous trading model with traditional auction trading model.

In EEX system in Central Europe, only block bids can participate in Continuous Trading auctions, while both hourly bids and block bids can participate in APX Power UK and N2EX in United Kingdom.

Second important difference from auction trading is that as the bid is reached to the market operator, if pricing matching conditions are met, bid is matched according to time priority, who comes first wins auction. This situation brings another difference from traditional auction trading is that electricity price in transactions is not equal to each other at each 1 hour period. In one hour, there may occur many pricing. Therefore, it cannot be regarded as Uniform Price Model. In APX Power UK and contracts are priced at bid prices as in Pay as Bid model. However, as in EEX model and in Borzen system in Slovenia, some rules are applied to determine the price of electricity. EEX and Borzen take all the bids into consideration while determining contract price. EEX and Brozen apply the following rules:

- if an incoming bid encounters an order book where there are only bids with price limit on the opposite side of the book, the price is determined by the respective highest bid or lowest purchase limit in the order book;
- if a bid without price limit is entered into an order book where there are only bids without price limit on the opposite side of the book, this bid is executed at the reference price and to the extent possible;
- in all other cases the incoming bid is executed against the bids without price limit, according to price/time priority, at the reference price or higher (at the highest limit of executable bids) in the event of unexecuted purchase bids, or at the reference price or lower (at the lowest limit of executable bids) in the event of unexecuted sale bids, respectively.

Continuous trading bids are matched in accordance with accepting price of opposite side. As an EEX rule, bids without price limit have priority over bids with price limit. Selling bids which include lower price limits have priority over higher limits. Similarly, buying bids which include higher limits have priority over lower limits. In case of including the same limits, time criteria is applied. The time criterion is as follows; who comes first, win auction.

As a result, continuous trading is more transparent for decision making for market participants. After careful strategies, market participants have more chance to get more revenue. Depending on the careful strategies of market participants, dispatching can become more efficient and efficiency can also occur in financial side too. This is because continuous market is much prone to competition at any second in the market. Another advantage of continuous trading is that, liquidity of day ahead market. Since, bidders can change their bids any time; possibility of occurring of transactions becomes more. Continuous trading system also assures of obtaining not less than their bid for energy [16].

On the other hand, continuous trading is much complex and difficult to follow and monitor. At any second, changes occur in the market. Continuous trading has another disadvantage that it increases gaming of bidders and virtual bidding since all bids are visible.

4.6 Mechanism of Day Ahead Markets

Day Ahead Market operations are conducted in an hourly and daily basis. Each and every day starts at 00:00 o'clock and ends with 00:00 o'clock at next operation day. 24 hour is divided into 24 equal periods of hours starting with each hour and ends after 1 hour. Market participants offer their bids for 24 different hour periods. Each bid can be different in quantity of power and price per power. This gives flexibility for sellers about determining their bidding prices. Buyers have also the same flexibility regarding the demand bids. Buyers have chance to propose different quantity of power and price per power for each different hour period to maximize its own profits. Hence, both buyers and sellers have chance to manage their own portfolios.

Bids of Day Ahead Market are fixed amount of supply or demand quantity. It means each seller should submit fixed amount of power quantity bid to the market operator. There cannot be any alterations for bids of buyers too. Buyers should demand for a fixed amount of energy in each period.

All bids submitted to the market operator related with Day Ahead Market is valid for a predetermined energy region if market splitting is applied. For a market splitting case, each country is divided into regions. Energy bids are submitted for different regions by market participants. All regions are independent from each other. Independence is related with prices and quantities. For the same period of time, different regions can have different market prices. This gives freedom to buyers and sellers to participate regional market bids. There is no obligation to attend for all regions. Market participant only bids by taking self profit into consideration. However, balancing of system requires transaction of energy among regions. Market operator determines the amount of energy has to be transferred from one region to another one. Because while balancing supply and demand, whole system is considered to be one and balancing is done according to this rule. If market splitting is applied, transmission restrictions are taken into consideration, on the other hand if market splitting is not applied; transmission restrictions are not taken into consideration while balancing supply and demand.

After having agreed to a fixed price and quantity in an hour period in day ahead market matching algorithms, market participants are liable for supplying either demanding the agreed quantity of power or buying the agreed quantity of power physically. If market participant is a seller, as a seller, it is obliged to supply agreed amount quantity of power at this time interval physically to the system grid.

4.6.1 Process of Day Ahead Market

Day Ahead Market is conducted in daily basis. All process starts and ends one day in advance of actual transfer of energy.

First of all, system operator determines the usable transmission capacity of energy in an hourly basis and gives this transmission capacity information to the market operator. Market operator decides transmission capacity by bearing in mind to the bilateral contracts and transmission congestions. Since system operator aware of transmission capacities of grids and bilateral contract, system operator can decide remaining transmission capacity of any grids in the system. System operator informs market operator about usable transmission capacity of transmission grids in an hourly basis. Then market operator deliver usable transmission capacity of transmission grids in an hourly basis to the market participants. In Turkey, market operator is obliged to submit this information till 09.30 a.m in the morning to the market participants.

11:30 a.m is the deadline for submitting bids for day ahead market for market participants in Turkey. Bids submissions are done via software. In Turkey, this software is called Market Management System, abbreviated as PYS. In different regions of USA, Europe and rest of the countries which employs Day Ahead Market, different software programs are used. Each and every submitted bid is evaluated by market operator according to the rules and regulations. In Turkey, market operator checks the submitted bids committed to 57th Article of Balancing and Settlement Regulation till 12:00 a.m. Each bid can be accepted or rejected by market operator. Figure 25 depicts how day ahead market process algorithm is applied. [15]

After having received all bids, between 11:30 a.m and 1:00 p.m market operator has to calculate day ahead market clearing price of electricity in accordance with the submitted bids. This market clearing price should be calculated for each period of hour for the next day. Thus, each hourly period has different market prices. This situation is depicted in Figure 26 while considering that supply curve is the same at each hour of the day, whereas demand is changing at each hour period of day. In reality, both supply and demand changes for each hour period. [15]

As shown in Figure 26, after midnight, demand is less, production costs are at base level, so market clearing price is at lowest level. It should be kept in mind that, intersection of supply-demand curve reveals market clearing price. On the contrary, at rush hours such as 7 p.m for demand side, a producer should work more to meet demands. As a result, market clearing price increases. Therefore, in a day, at each and every hour, different market clearing price emerge.

Similarly, for each region, the market clearing price is calculated separately by market operator in accordance with submitted bids for related regions. As in different time periods; every region has its own conditions while determining their bids. Supply side can have more

competitors for a specific region, so supply curve can decrease. Supply side can have much expense in a specific region; as a result, supply curve can increase. Demand side can also increase its demand curve due to amount of future predicted amount of energy in a specific region. All supply and demand sides have flexibility to bid for electrical energy.

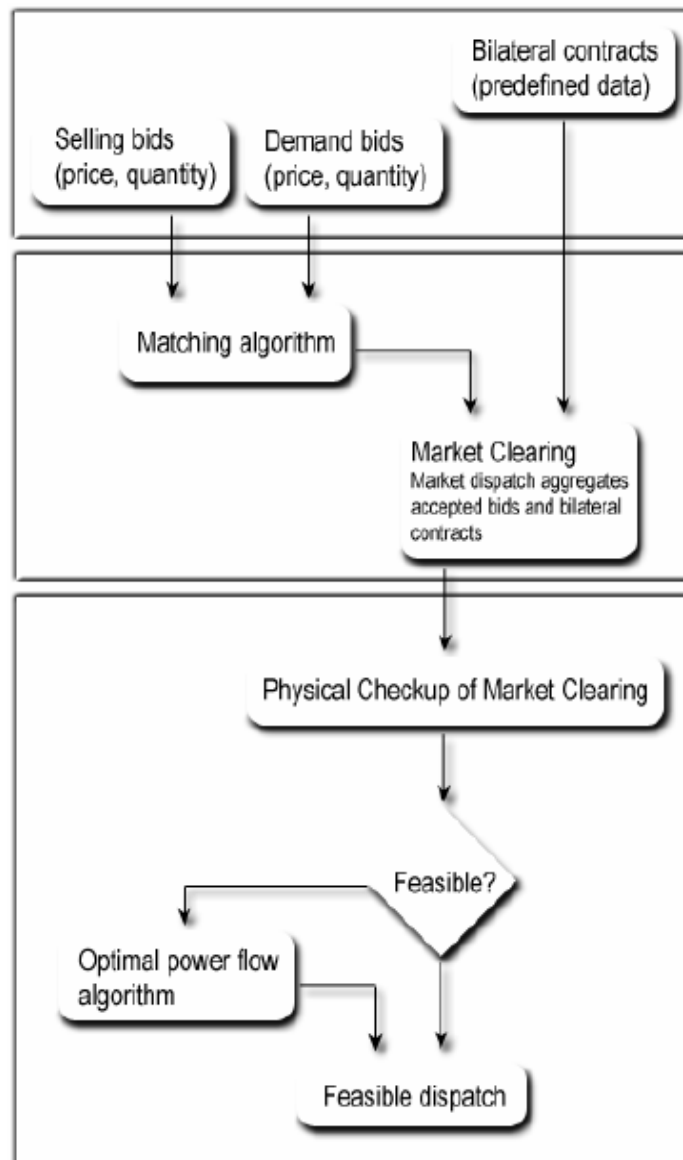

Figure 25 Typical Day Ahead Market Algorithm [17]

In Turkey, right after the calculations and matching of bids of market at 1:00 p.m, market operator need to send to the market participants all approved buying and selling quantities and prices that will be held next day. Therefore, all related market participants have chance to check the resultant trading and have right to raise objection. In Turkey, all market participants have right to object till 1:30 p.m. Objections are to be done to the market operator directly. Objection process continues with the evaluation of objections by market

operator. Market operator evaluates the objections between 1:30 p.m and 2:00 p.m in Turkey. [15]

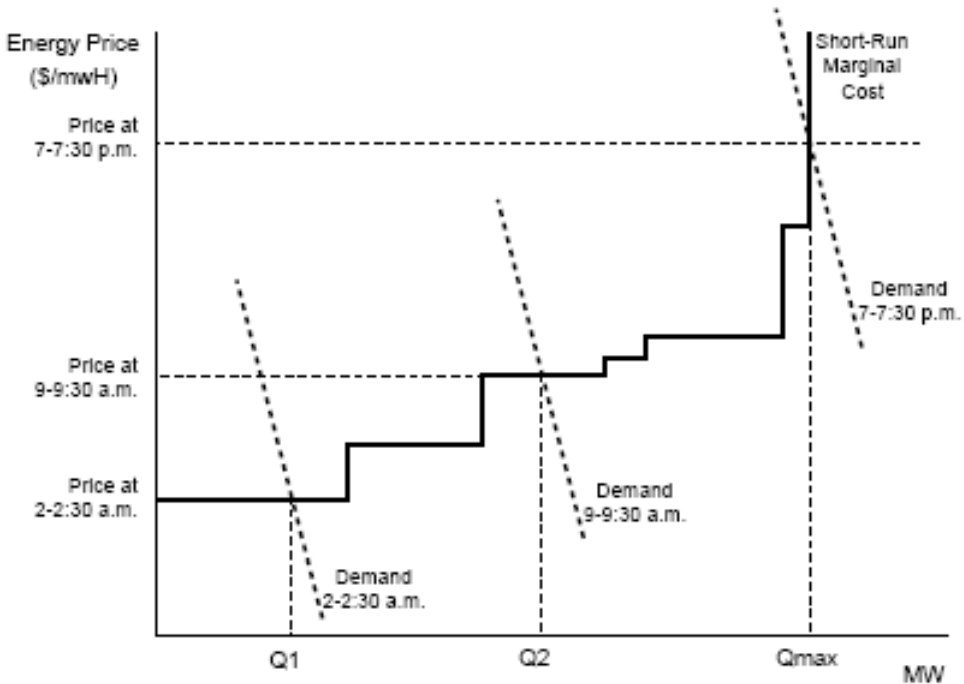

Figure 26 Differences of market prices and bids in a day [17]

Similarly, all over the countries which apply day ahead market, system have nearly 30 minutes durations for obligations and evaluations of obligations. After 2:00 p.m, market operator informs, whether accepted or rejected, the relevant market participants about result of objections. If objection is accepted, corrected results are sent to the related participants. Therefore, at 2:00 p.m, all trading related with energy is completed one day before actual energy transmission. The resultant trading does not violate transmission restrictions. Since all producers have right to make their own bid as they desired, and day ahead market matching assures more efficient in financial way for both suppliers and demanders. On account of producing and demanding bids are submitted freely in market, there is not a loser in the system. All market participants decide their own success by themselves. Winning day ahead market auction is related with bids of companies, not with others. All calculations and matching procedure is transparent so that there is no unfair competition. Avoiding unfair competition is the fundamental Article of liberalized deregulated market. All market participants are equal and their bids are evaluated only considering their bids. Since market also has objection mechanism, day ahead market system compromises control loop which can reduce the risk of faults and brings justice to the electrical energy trading system.

4.6.2 Bids of Day Ahead Markets

Day ahead market is trading of electricity one day ahead of physical transfer of energy. Therefore, one day ahead of actual transfer, operations and matching are conducted by

market operator according to bids. As it can be understood from the day ahead market definition, bids must be submitted to the market operator one day before of physical transfer. However, for the weekends, off days and national holidays, every country adopts different scheduling for bidding. In Turkey, market opens 5 days ahead of physical transfer so that market participants can submit their bids 5 days ahead of transfer. Market is closed at different hours in every country one day ahead of actual transfer. In Turkey, deadline of bid submission is 11:30 a.m one day ahead of physical transfer. Bids are evaluated after 11:30 a.m in Turkey. [15]

Bids of Day Ahead Market include mainly 2 different parameters. One of this parameter is quantity in MW; and the other parameter is price in TL/MW. Each market participant make quantity and price bid.

Day Ahead Market requires submission of bids 1 day ahead of actual transfer of energy. Thus, bids should be submitted as hourly basis to the market operator by participants. Moreover, one can offer bids as blocked bids. Blocked bids includes more than 1 hour period. So, for more than 1 hour interval, one participant can have bid. However, this bid has only one quantity of power and price per power. That is for a specified time interval, participant make only 1 bid. This means, each and every time interval in this blocked time has the same quantity and price offered. 3rd type of bid is flexible bids. For flexible bids, external from hourly buying and selling bids, should include selling prices without regarding a specific time interval for the next day.

Bids should be realistic and feasible. One producer should not offer more than its capacity. Producer and buyers should take bilateral contracts into consideration. In the same manner, consumer should make a feasible prediction over demand in an hourly basis. By the help of predicted demand data, it should enter competition. Otherwise, because of faults in estimation, Consumer Company can pay extra money for unused bid capacity. Prediction of consumption is the key point for making profit for consumer market participants.

Bids of quantity and price can be different for each time interval. All the price bids have resolution of 1% in Turkey and prices can be declared in Turkish Lira, Dollar or Euro in Turkish Market. Rate of exchange is based on daily exchange rates of Turkish Central Bank. Resolution of quantity of power is defined as 0.1MWh and its multiples in many Day Ahead Markets around the world as in Turkey. 0.1MWh is equal to 1 LOT and bids are submitted in LOT. [15]

Submitted bids in should include the following information:

- Name of market participant and the participation code to the Day Ahead Market
- The day which bid is valid
- Valid time intervals of bids
- Valid zones of bids
- Quantity of power information
- Price information

All of the related information that should be submitted to the market operator to attend Day Ahead Market is presented to the market participants through software program. Market participants fill the required information as they desire to attend bidding auction.

Another important rule is that a market participant can only apply for trading if this market participant has a production or consumption or bilateral contract among this area, in cases of market splitting is applied. When there is not such a rule, competitors, can manipulate regional prices by entering auctions with dummy prices and quantities. Therefore, prices may increase upon non realistic bids. Such restriction improves efficiency of market and overcomes non deserved profits.

Content of hourly basis bids have some details. For Turkish Day Ahead Market System, each buying and selling bid for a specified hour interval should have maximum of 32 price levels in both buying and selling price-quantity couples.

Another rule for the bids of market participants is that, one level of any price can be committed to either buying or selling for any specific period of time. One cannot bid for both hourly buying and hourly selling at the same price.

There are also upper and lower bounds for both buying and selling bidding prices. These limits are determined by market operator and boundaries are informed to the market participants via software program with which market participants make their bids. Maximum limit is determined much higher than the forecasted actual price. Market operator defines these limits in accordance with market conditions and all these prices can be changed by market operator, although in Turkey these values are fixed. According to these maximum and minimum limits, market participants list their bids from lower price to the upper price. For each and every price value, there must be only 1 quantity in MW. This power quantity can be only buying or selling. For the same price, there cannot be more than 1 bid quantities or type. Table 2 depicts a bid given by a buyer company for a specific 1 hour.

Table 2 Buyer bidding example

Price, (TL/MWh)	0	10	11	25	30	39	40	59	60	80	100	150	
Participant A, (Buyer) Quantity (MW)		50	50	40	40	40	40	30	30	20	20	20	20

As depicted in Table 2, market operator declares minimum limit as 0 TL/MWh, as well as maximum price is 150 TL/MWh. Assuming that buyer company A desire to attend the day ahead market; buyer company A need to compute the most feasible and efficient price-quantity couples. After calculating how much it can buy at a specific price, it should list the bidding table as shown in Table 2. Table 2 explains that A company can buy 50MWh if the day ahead clearing price is less than or equal to 10 TL/MWh. Similarly A Company accepts to buy 40MWh if day ahead market price is between 10 TL/MWh and 40 TL/MWh.

According to the bidding table in Table 2, company A bids for 20MWh if the market clearing price will occur between 60 TL/MWh and 150 TL/MWh.

Companies can bid for either selling or buying at the same bid. However, the only criteria need to be followed is that one price level can include only selling or buying price. Yet, for different price levels, there is no restriction for determining buying or selling. Market participants make decision to be a buyer or a seller at a specific price by itself; regarding the profits of its own company. Table 3 demonstrates bidding style for a market participant which desires to attend day ahead market as both buyer and seller in a specific 1 hour period.

Table 3 Mixed type of bidding example

Price, (TL/MWh)	0	10	11	25	30	39	40	59	60	80	100	150
Participant B, (Buyer and Seller)	30	30	10	10	10	10	0	0	-20	-20	-20	-20
Quantity (MW)												

Assuming that Company B is both producer and consumer, Table 3 explains that company B is ready to buy 30MWh if day ahead market price is announced less than or equal to 10 TL/MWh. Company B will still continue buying energy amount of 10MW in specific 1 hour interval if the price of electricity is announced between 10 TL/MWh and 40 TL/MWh after day ahead market calculations. Between 40 TL/MWh and 59 TL/MWh is a critical price of Company B, since it does not make any offer for buying or selling. Because Company B foresees that between 40 TL/MWh and 59 TL/MWh is not feasible for this company to attend day ahead market. However, as the price goes up to between 60 TL/MWh and 150 TL/MWh, company B depicts that it is efficient to sell energy to the market at an amount of 20 MWh. That is why selling price is depicted with – sign in Table 3.

Block bids are also a kind of bidding strategy for market participants. Market participants can bid for a consecutive full time periods. The block order is particularly useful in cases where the cost of starting and stopping power production is high. Furthermore, inflexible production, consumption and contracts can be handled efficiently with block orders. In practice, block orders are widely preferred by Thermal Power Plants.

Both buyer and seller can have chance to make block bids. A market participant submits bid in unit of TL/MWh at a given time interval. This block has fixed price and do not change as in 1 hour bids. As in hourly buying and selling bids, market participant can bid for a selling for a time interval, whereas buying can be bided for another time interval. The only difference is that, the bid is given for not a 1 hour period; conversely bid is submitted for more than 1 hour period for a day.

One participant can make more than 1 block bid for different periods or the same periods of a day. System operator can identify the hour blocks which can be used for block bidding and informs the market operator; market operator applies this rule to market participants. On the

other hand, market operator can give chance to market participant to identify their own block bids so that participants can decide their own block bid intervals. However, in Turkey, for such a self-decided block bids, there is an obligation to submit block bids which must cover minimum 4 hours period. Again as a Turkish regulation, a participant can submit maximum 50 bids in a day.

Recognition of block bids have also some rules. Each and every block bid is accepted as a whole block or rejected as a whole block. There cannot be any separation for accepting or rejecting the block bids. A whole block is regarded as one unit.

Table 4 shows an example for a block bid.

Table 4 Block bid example

Block Hours	Participant C, (Buyer and Seller) Price (TL/MWh)	Quantity (MWh/h)
00.00-06.59	110	100
07.00-14.59	50	30
15.00-17.59	35	-30
18.00-23.59	20	-100

For a market participant C, it chooses to make block bid in a day. Market participant C also chooses to be either buyer or seller depending on the time interval and related price. It does not submit specific price-quantity couples for each specific 1 hour period of a day as exemplified in Table 2 or Table 3. Instead of this, participant C chooses to make block bids. Table 4 illustrates that participant C is making block bids between 0 a.m and 06:59 a.m. At this time interval, participant C is ready to buy 100MWh/h at a price of 110 TL/MWh. It means that, company C is submitting bid 100 MWh at a price of 110 TL/MWh between 0 a.m and 1 a.m. Other price values correspond to 0 MWh for period between 0 a.m and 1 a.m. between 0 a.m and 1 a.m, bidding of participant C corresponds to the Table 5.

Table 5 Block bid in market bidding format

Price, (TL/MWh)	0	10	11	25	30	39	40	59	60	80	110	150
Participant C, (Buyer and Seller)	0	0	0	0	0	0	0	0	0	0	100	0
Quantity (MW)												

Similarly, participant C is ready to buy 30MWh/h between 7 a.m and 3 p.m if the day ahead market price is announced as 50 TL/MWh. Conversely, according to forecasts of participant C, it can find it feasible to sell energy at price of 35 TL/MWh.

For time interval between 3 p.m and 6 p.m, company C bids for selling of energy at a price of 35 TL/MWh at a quantity 30 MWh/h. As shown in Table 5, one company can bid block bids as both buyer and seller.

4.6.3 Market Operator

Market operator is the core of day ahead market system in that market operator manages the day ahead market system. In Turkey, market operator is called “Market Financial Settlement Center”, abbreviated as MFSC. MFSC works under Türkiye Elektrik İletim A.Ş, in short TEİAŞ.

Market operator has to manage day ahead market and publish related market data in a transparent, fair, responsible and without discriminative manner among equal sides. Therefore, market operator need to be at equal distance from all market participants. [15]

In all parts of the world which employs day ahead market, market operator need to establish and manage the electricity market depending on the related upper legislations. Market operator has also responsibility to prepare, present and publish internal legislations about managing of market that are binding for all market participants. Market operator has to take decisions about application phase of market. As any upper level systematical problems detected while application of day ahead market, market operator informs and advices on solutions to the law competent authority.

Market operator has the following duties while managing day ahead market in chronological steps as follows:

- Market operator must inform market participants about transmission capacity of grids.
- Market operator must collect bids from market participants.
- Market operator must evaluate bids according to related legislations.
- Market operator must calculate and present Market Clearing Price of Electricity of day ahead market and resultant dispatching according to given bids
- Market operator must inform market participants
- Market operator must evaluate objections

Market operator has also responsibilities regarding with balancing and settlement mechanism.

Market operator need to make reconciliation. For balance and non balance mechanism, market operator must calculate the prices, debts that will be collected. About prices, debts that will be collected, market operator has a duty of preparing declaration.

Another important duty of market operator is that it must publish data and prepare reports related with market. In Turkey, Energy Market Regulatory Authority, abbreviated as EMRA, which is an impartial organization and has a duty of supervision of market, can want to take reports regarding with Day Ahead Market. At such cases, market operator prepares reports for EMRA and publishes them. [15]

Market operator need to inform system operator about market with required information. General information, statistics related with market as well as wholesale electricity prices are also published periodically by market operator.

Another duty of market operator is to follow the bidding prices and instabilities of prices that are bided by market participants in a billing period. Some participants may increase their instability related with price biddings. At these cases, market operator must detect these instable participants and desire to get extra collateral for not to destabilize the whole market operation.

4.6.4 System Operator

System operator is the operator which is responsible from physical management of grids. In Turkish Electrical Market System, System Operator is called National Load Dispatch Center, abbreviated as NLDC. NLDC is an organization of TEİAŞ. [15]

Likewise Market operator, system operator must be transparent, fair, responsible and without discriminative manner among equal sides.

For day ahead mechanism, system operator has mainly 3 responsibilities. System operator plays role at the beginning and at the end of day ahead market dispatching process. First of all, at each day ahead market process day, system operator has to forecast demand of the next day in an hourly basis. By using forecasted data and bilateral contracts among traders, system operator has to calculate the transmission capacities of grids. After calculating the grid capacities, system operator needs to inform market operator as the starting point of day ahead market. By supplying capacity information of grids to the market operator, it is guaranteed that minimum congestion and minimum dispatching errors will occur. As an end point of day ahead market dispatching, system operator checks the feasibility of dispatching that is completed by market operator.

3rd responsibility of system operator in day ahead mechanism is that system operator defines bid regions and borders of trading so that market participants can make bids for different regions.

If fault occurs in transmission system related with grids and transformers, system operator needs to inform market operator so that market participants can aware of the fault and adjust

their bidding prices. Not only for faults, but also for the maintenance processes are needed to be informed by system operator.

Outside of day ahead market mechanism, system operator is responsible from balancing supply and demand energy in real time. Moreover, system operator needs to give the related information to the market operator about balancing and settlement process. Preparing reports of physicality of grids to the authorized organization is another duty of system operator. Authorized Organization is EMRA in Turkey. System operator has to use transmission capacity of grids in most efficient way because forecasted transmission capacity of grids restricts bids of market participants in day ahead market. As a result, electricity price can increase or decrease. This is directly related with forecasting success of system operator.

4.6.5 Crimes and Sanctions in Day Ahead Markets

Punishments for illegal activities change from country to country, however crimes remain the same in all day ahead markets. In this section, punishments will be explained that are applied in Turkey based on Energy Market Law number 6446, Article 16. Not only Energy Market Law number 6446, Article 16; but also specific secondary laws are applied to the market. [18]

In Turkey, outside of market operator and system operator governed by TEİAŞ, there is an institution called Energy Market Regulation Authority, abbreviated as EMRA. EMRA is neutral institution which has duty of regulation and control of energy market, as well as day ahead market. EMRA is the institution step which applies rules and where market participants can complain. Therefore, EMRA has the right to evaluate illegal actions and punish these crimes. EMRA is also responsible for publishing secondary rules for the market. Secondary, on the other hand, Turkey has second authority which is related with competition. This authority is called Competition Authority. Competition Authority is responsible for creating a fair competitive area in the market. Hence, crimes related with competition are evaluated by Competition Authority.

EMRA has right to get information from market participants or has right to investigate the market participants at their own place. Unless information is given to the institution or unless participants let investigators from EMRA, written warning is given to the market participant for the fifteen days to change illegal action. However, as related market participant continues its illegal action after fifteen days, it is fined 500 000 TL. [18]

Secondly, in cases which a market participant is behaving out of licensing provisions, laws and legislations according to Energy Market Regulations Laws, is warned in written way depending on the type of illegality. If illegality is a type of recoverable violation, related market participant is warned to correct illegalities in 30 days. Yet, as the violation continues after 30 days, market participant is punished 500 000 TL. If illegality is a type of non recoverable violation, market participant is punished 500 000 TL without warning in written way. [18]

During application process of licensing or during licensed period, if a market participant propose unrealistic documents or illusory information or do not inform about the changes which affects licensing procedures; is fined 800 000 TL. As the related market participant do not correct unrealistic documents or illusory information or changes which affects licensing procedures in 30 days, license of related market participant is cancelled. [18]

During licensing period, if material subsidiary relationship ban is violated by a market participant, market participant is warned to change material subsidiary relationship in 30 days. As there is no change after 30 days, related market participant is fined 900 000 TL. [18]

As it is detected that a market participant is having operation out of scope of its own license, related market participant is warned to cease the out of scope operation in 15 days. If there is no cease in operation which is out of border of license, related market participant is fined 1 000 000 TL. [18]

Conditions which are the basis for licensing can be destroyed or removed during licensed period. In this case, related license is cancelled.

However, for the pecuniary punishments listed above, council can apply different timing period for written warning according to type of act. In warning period and removal of illegal actions period, as market participant insist on continuing illegalities, pecuniary punishments are doubled. In case of acting the same illegal behavior in two years again, pecuniary punishment is increased exponentially. If cumulative pecuniary punishment exceed 10% of its revenues, council has right to cancel licensing.

Not only above crimes are committed. Market manipulation is also a type of crime and should be detected by regulator. As an example, N numbers of companies which have market power have an agreement. N-1 company decrease production capacity intentionally; however, they declare reason of capacity withholding as maintenance, repair or technical problems. Hence, only 1 company enters in bidding and supply most energy to the system by itself. Thus, energy price depend bids of one company. As a result, price of day ahead market increase unfairly. As a result one company makes huge profit. This profit is then divided among N companies. Hence, all companies make more profit more than they deserved. Such a physical withholding and manipulations should be followed by market regulator. Such punishments are given by EMRA in Turkey.

4.7 Day Ahead Market and Real Time Markets Comparisons

As explained in previous sections, a day ahead market is a market for electricity trading which operates one day before of the actual transfer day. Real time markets operate in an hour trading periods on the actual transfer day. Day Ahead Markets are a kind of forward market. Day Ahead Market is both a financial market and a physical market.

Financial Market is the market type in which market participants can purchase or sell energy on the market without having an obligation for delivering the energy. Non delivered energy is compensated via financial transfer. On the other hand, physical market needs to transfer the agreed amount of energy at defined time interval.

Real Time Market is regarded to be as a purely physical market. Thus, electricity energy needs to be transferred instantaneously.

If there is no strict distinctions between Day Ahead Market and Real Time Market, a participant can change the day ahead trading schedule just before real time markets so that participant can have no clear advantage and profit by manipulating real time prices. Therefore, Day Ahead Markets and Real Time Markets are different in theory and they should be distinct in application too. Distinction of Day Ahead Markets and Real Time Markets is the main solution of these manipulations. Separation requires the prices and power quantities specified in day ahead market are financially binding and should not have a link with prices and power quantities specified in real time market. Separation of Day Ahead Market and Real Time Market is called “two-settlement” system.

In any system that is applying two-settlement system, trading primarily is actualized on the day ahead market. Any lacks or non balanced system energy is compensated and traded via real time market. Both producers and consumers are free to enter real time market regardless of entering day ahead market. Real time market is used to compensate the deviations occurred from day ahead market. For example, a supplier company is ready to sell 30MW power to the day ahead power with a price of 5TL/MW. Upon bids, forecasted demand is seem to be 30MW. Assuming that optimum dispatching is realized by taking power from this supplier, offer is now financially binding. When the real market time gets closer, supplier have chance to alter offer to 4TL/MW. As a real time calculation, suppose that demand occurs to be 25MW that is lower than expected quantity in day ahead market. 150TL is paid to the supplier because of day ahead market’s financial binding. Since supplier entered to the real time market and real time market closed at 25MW, 5MW power is bought back by producer. 20TL is paid by producer to get 5MW extra power. As a result, deviations are settled in real time market. To formalize, if we say that

q_{rt} is the quantity in real time market

q_{da} is the quantity in day ahead market

p_{rt} is the price in real time market

p_{da} is the price in day ahead market

Total revenue of supplier becomes:

$$p_{da} q_{da} + p_{rt} (q_{rt} - q_{da})$$

4.8 Hardware and Software Infrastructures of Day Ahead Markets

Hardware and software infrastructure of day ahead markets play an important role in day ahead structure in that market participants, market operator and system operator have connection via infrastructures.

Firstly, software infrastructure is the key of day ahead market primarily. Software program is used by system operator, market operator and market participants.

All day ahead markets throughout the world has software infrastructure. Software program is running over thin client hardware structure which is secured by specific network software, such as Virtual Private Network as in Turkey.

As an interface between system operator, market operator and market participants, software program must have the following capabilities: [15]

- Predetermined bidding regions are announced by market operator to the system operator and market participants via software program.
- Transmission capacity that can be used is to be announced through software program by market operator.
- System operator announces the types of bids, information which has to be included in bids through software infrastructure.
- System operator informs market participants about maximum, minimum limits of supply and/or demand prices that can be bided through software program. According to the changes of market conditions, maximum and minimum limits can need to be altered. Such alterations are announced via software program.
- Suppliers of day ahead market make their active electrical energy supply bids for each hour interval of next day through software infrastructure.
- Buyers of day ahead market make their active electrical energy demand bids for each hour interval of next day through software infrastructure
- The right for making individual block bids is given to the market participants through software infrastructure by market operator.
- Suppliers of day ahead market make their active electrical energy supply block bids for predetermined interval or self determined interval of next day through software infrastructure.
- Demanders of day ahead market make their active electrical energy demand block bids for predetermined interval or self determined interval of next day through software infrastructure.
- Suppliers of day ahead market make their active electrical energy flexible supply bids of next day through software infrastructure.
- Demanders of day ahead market make their active electrical energy flexible demand bids of next day through software infrastructure.
- After submission of bids to the database, software denotes a registration number for each and every bid. All bids are stored on database by saving date, hour, minute and second.

- For uniform price auction and pay as bid model, software must show only a participant's own bid to itself so that bids are visible only to the market operator. Other market participants' bids must not be visible to the other market participants. This is security of auction trading method.
- For continuous trading method, software infrastructure is more complex. Software infrastructure must be capable of changing bids and showing all bids to all participants so that market participants can change their bids at any second.
- For all types of models, all changes and bids are saved into software database so that if any problem or conflict occurs. Therefore, software and hardware infrastructure must be capable of storing all bidding information.
- Market operator expresses accepted and rejected bids, which are proposed by market participants, to the relevant market participant through software.
- Software infrastructure must be capable of determining market price on related day ahead market model. Therefore, software must be capable of computing and finding the most efficient price while balancing supplied and demanded energy.
- Market operator announces the resultant market price or contract prices through software.
- Market operator announces the approval of trading operations through software.
- Objects to the approval of trading operations are done through software. Results of objections are announced by market operator to the related market participant via software.
- Announcements of market participants are also completed via software.

For Thin client structure, there must be a server running on Linux / Unix or Windows, established in system operator's operating building. This server must be strong enough from point of processor and RAM properties so that server can be able to handle all bidding operations quickly, respond to operations on time, store all the data offered to the system by market operators, and store all related data presented listed above. Server is connected to a "Main Switch". Main switch plays a role between server and clients. Clients make connection to the switch and switch makes connection with server.

Whole hardware structure is secured by Virtual Private Network, abbreviated as VPN. All participants can join to the Virtual Private Network by using their own computer as well as thin clients. Market participants, who wish to use their own computers, reach market network via Thin Clients' network. After having installed appropriate Virtual Private Network software, connection to the main switch of thin client can be completed. Therefore, personal computers, which use Windows as operating system, get ready to connect market network. Similarly, by using iOS operating system from iPhone or iPad, a market participant can join network using Virtual Private Network property of devices. Another technique for reaching network is using thin clients. [19] A market participant can have only thin client, USB output keyboard, USB output monitor and USB output mouse. For such a solution, there is no need for personal computer. If market participant do not wish to use personal computer, instead it For thin client case, main server supply RAM and processor to the thin client via switch so that market participant can complete all related operations on software running on network on its own monitor. Joining a Virtual Private Network requires IP

address, username and password. Such information is given by market operator. Therefore, username and password information must be hidden by server to other participants. A simple figure regarding the hardware structure is depicted in Figure 27.

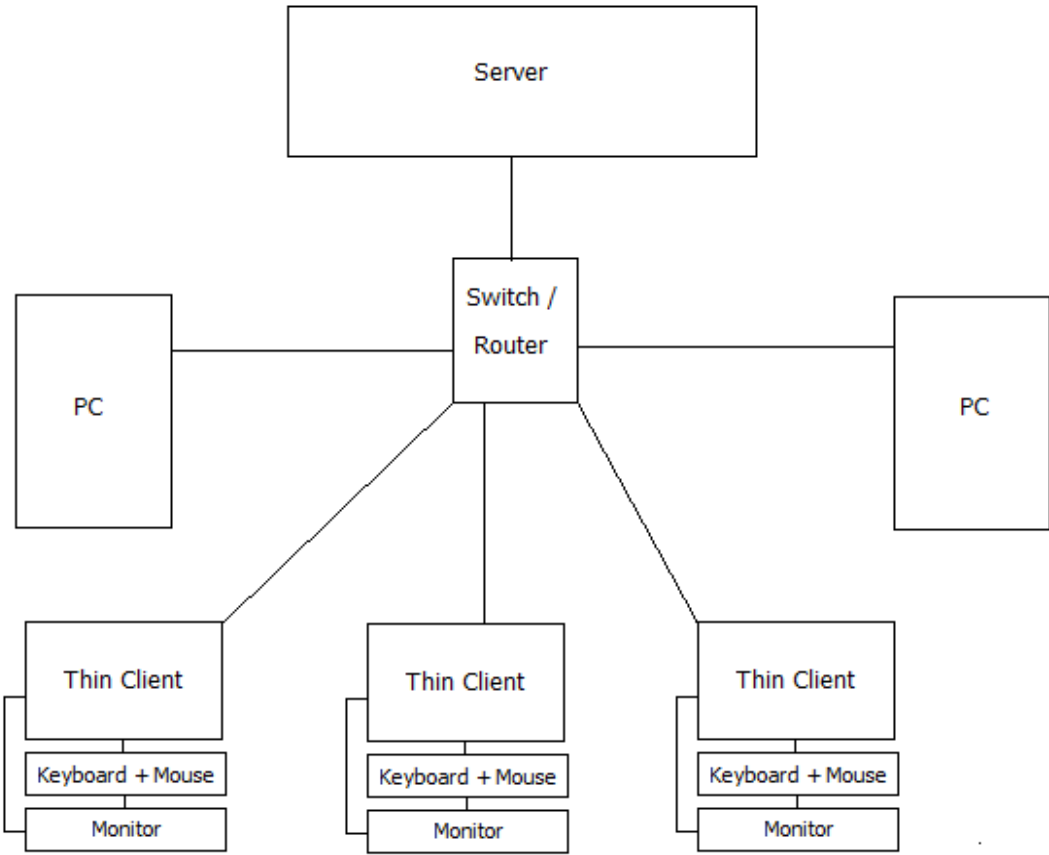

Figure 27 Hardware of day ahead market

As a result of hardware structure of day ahead market, others can not join network without having permission which is given and approved by market operator. Thin clients and Virtual Private Networks make day ahead market system more secure. In Turkey, Virtual Private Network is also used for securing whole day ahead market software system. Similarly, internal software program must have also high security in that none of market participant must not have chance to make alterations on others' bids.

CHAPTER 5

DAY AHEAD MARKET IN TURKEY

5.1 Legal Basis of Turkish Day Ahead Market

The Structure, model, operation and rules of Turkish Day Ahead Market is described in Turkish Electricity Balancing and Settlement Legislation. Turkish Electricity Balancing and Settlement Legislation were published in Turkish Official Gazette with a number of 27200 on 14 April 2009. Turkish Electricity Balancing and Settlement Legislation were updated lastly on January 5th, 2013 in Turkish Official Gazette with a number of 28519.

Turkish Electricity Balancing and Settlement Legislation are based on Article 1 of number 4268 law about Duties and Organization of Energy Market Regulation Authority. Duties and Organization of Energy Market Regulation Authority was primarily published in Turkish Official Gazette on 20 February 2001.

Number 6446 Law of Electricity Market, which aims to establish electricity energy market, covers law about Duties and Organization of Energy Market Regulation Institution.

Turkish Electricity Balancing and Settlement Legislation include dedicated parts to Turkish Day Ahead Market system. Chapter 3 of Turkish Electricity Balancing and Settlement Legislation, starting with Article 49 explains day ahead market in detail. [15]

- Article 49 is about operation of day ahead market is applied in Turkey
- Article 50 describes the process of day ahead market
- Article 51 includes determination and announcement of bid regions
- Article 52 includes determination and announcement of trading regions
- Article 53 describes the rules of day ahead market bids
- Article 54 includes the structure and content of hourly bids
- Article 55 includes the structure and content of block bids
- Article 56 includes the structure and content of flexible bids
- Article 57 includes the submission and confirmation of day ahead market bids
- Article 58 includes the process of price determination in day ahead market
- Article 59 includes determination of Constrained Market Bid Price (KPTF) and matching in day ahead market
- Article 60 includes process about removal of congestion, as well as determination of Final Market Bid Price (NPTF).
- Article 61 describes evaluation of block bids
- Article 62 describes evaluation of flexible bids

- Article 63 includes approval of trading operations
- Article 64 is about notification of day ahead market results to the system operator
- Article 65 includes the defection procedures of Market Management System which is the software interface
- Article 66 includes the notifications about day ahead market
- Receivable amount of sellers is calculated in TL based on Article 93.
- System selling prices are calculated in TL/MWh based on Article 94.
- Purchasing amount of buyers is calculated in TL based on Article 95.
- System purchasing prices are calculated in TL/MWh based on Article 96.
- Revenue based on day ahead markets, if exists, is calculated in TL based on Article 99.

The crimes and punishments of day ahead market is grounded upon Electricity Market Law number 6446, Article 16. Energy Market Regulatory Authority is authorized to control market, market participants and impose penalty actions according to the described rules and regulations in Electricity Market Law number 6446, Article 16; moreover, secondary laws and regulations are published by EMRA. Duties of Energy Market Regulatory Authority are described in number 4268 law about Duties and Organization of Energy Market Regulation Authority.

5.2 Envisaged and Applied Model

According to the published Electricity Market Law in 2001, TEAŞ is divided into 3 parts, i.e. EÜAŞ, TEİAŞ and TETAŞ. On November 2004, first Balancing and Settlement Legislation was published. The aim of Balancing and Settlement Legislation was adopting Day Ahead Balancing mechanism in order to optimize production of electricity. Day ahead balancing was aimed to facilitate real time balancing and acquiring system security. Although electricity prices remained almost fixed, costs for producing electricity increased during period between 2004 and 2009. This led losses and production difficulties for generators, especially thermoelectric power plants. In order to establish more efficient trading structure, many progresses were made.

First, balancing and settlement mechanism was started to be completed in an hourly basis. The primitive type is called, Day Ahead Planning. The main target was to switch Day Ahead Planning with Day Ahead Market. Day ahead planning was conducted between 2009 and 2011 as a transition period to day ahead market. Turkey has been utilizing day ahead markets since December 2011. Day ahead planning and day ahead market are different from each other in that for day ahead planning it was mandatory to join; because day ahead planning has been based on balancing whole system by operator. However, day ahead market is portfolio based. Each and every participant cares its own portfolio. Demand side did not have affect on determining prices on day ahead panning mechanism. Balancing mechanism is not based on demand forecasting. Another main difference is that in day ahead planning

system there was no market splitting. Market splitting is one of main and useful mechanism in day ahead markets.

Market splitting was one of the main targets of day ahead marketing. By means of market splitting, market has chance to adjust electricity prices according to each region's supply demand relationship, plus interconnection to other regions. Hence, all regions have their own price, called as NPTF, as explained in Chapter 4. This would make transmission congestions manageable. Hence, scarcity of electricity in some regions would be eliminated. This is because only one pricing and supply demand balance is applied in Turkish system without taking transmission limits into consideration in day ahead market. [15]

Generators of Turkey are mostly installed in east region of Turkey. However, the produced electricity in eastern regions of Turkey may not be able to transmit to other parts of Turkey because of transmission limits on grids. Therefore, surplus of electricity occurs in eastern regions of Turkey. On the other hand, western region of Turkey has more electricity demand than eastern region in that population and industry is mostly located in western part. Since, transmission grids do not let all produced capacity transferred to western part, one of envisaged plan was to split Turkey into regions. In result, each region would have different prices, NPTF. Since supply is much greater than in eastern region, NPTF of eastern regions would be low. Thus, it was planned that after market splitting, industrial organizations can be urged to invest in eastern regions because of low electricity prices, and then eastern regions would be much developed. From electricity manner, there would be less surplus, even supply demand balance. Hence, supply demand balance would be acquired; there would be no waste of electricity. On the other hand, for western regions, NPTF would be high compared to eastern parts, because demand is higher than supply in western regions. This would be attractive for supply side market participants to sell electricity from higher prices. In conclusion, in all regions of Turkey, industry would have chance to be developed in all regions as well as plant installations. As a whole result, Turkey would have more chance to control transmission congestions. This would lead Turkish energy supply more healthy and reliable. However, market splitting could not be realized and operations are conducted in market as Turkey is only 1 region and interconnection between industry and electricity generation could not collaborate.

For Turkish electricity market, day ahead market has the auction bidding structure of uniform market price trading. Market is managed by market operator, abbreviated as MFSC. System is managed by National Load Dispatch Center, abbreviated as NLDC. Both MFSC and NLDC are under TEİAŞ. Market participants may not also see other market participants' bids. As detailed in Chapter 4, uniform price trading is based on one step auctions so that bidders have no chance to make changes on their bids according to the other bids submitted by other competitors. This means there is no transparency in bids. However, near soon, to overcome transparency issues and to obtain reference market price for electricity, intraday market is planned to be employed in Turkish day ahead market together with traditional uniform price trading. This model is applied in some European models, such as United Kingdom and France. New system will throw light on market participants to determine their

own bids. Because in this system, they will be able to see others bids, to change their own bids so that market participants will have flexibility on their bidding style. New market will look like stock exchange and will be held by Electricity Markets Management Anonymous Company, abbreviated as EPIAŞ. EPIAŞ will be under structure of Istanbul Stock Exchange.

Turkish electricity industry was aimed to be liberalized, so that market can decide its own price with fully competitive market. Day ahead market emerges as a result of liberalization. Day ahead market is based on fully competitive market. The rule of thumb of a competitive market is establishing purely equal and fair market. All supply and demand sides are free to make their own bids. However, if there is any cross-subsidization in market, competition becomes unfair since cross subsidization implies the support of interconnected foundations, such as two different vertically bundled company may support each other which destroys fair and equal competitive ground. In Turkey electricity market is aimed to be liberalized in production phase. However, as 2013, governmental companies have 40% percentage of total electricity production. This leads generator companies avoid joining day ahead market. Therefore, Turkey has been privatizing its power plants in order to have fully competitive market. At first Turkey aimed to have privatized power plants.

5.3 Problems in Application

Day ahead market has been adapted to Turkish system on December 2011. Right after the establishment of day ahead market, market participants hesitated to enter to the day ahead market, keeping in mind that day ahead market is not a mandatory market to attend. Most percentage of electricity trading was based on bilateral contracts. As of April 2012, more than 90% of electricity energy trading was based on bilateral contracts. This was because the day ahead market was not a settled system and companies were not aware of newbie system. Although an imaginary market was developed and conducted by MFSC via software in order to adopt market participants to new system, in reality, market participants did not show interest on day ahead market. However, as 2012 February and March, natural gas shortage and as a result, sharp increase of prices of natural gas in Turkey, electricity market started to attract participants more. At the same period, demand also increased. As a consequence, wholesale and retail sales companies started to attend day ahead market to obtain electricity. Since wholesale and sales companies attended market, production companies started to attend market inevitably. Hence, day ahead market was started to be utilized by market participants. As of 2013 August, the percentage of trading volume of day ahead market is around 20%. Nevertheless, as of August 2013, 45% of whole energy market participants do not participate in day ahead market. The aim is to increase the attendance and trading volume of energy in electricity energy trading.

Day ahead market has an aim of determining reference market prices of electricity. According to results of day ahead markets, prices should give clues to market participants about their bidding strategy. One problem in Turkey during application of day ahead market is related with reference price of bidding. Market participants can not be able to make exact strategies on their bidding mechanism since there is no reference price as a result of day

ahead market. Thus, market participants may not bid in optimum prices. Therefore, many fluctuations occur in bids, resultant market clearing price as well. According to data presented by MFSC, 30.38% of electricity is produced by natural gas. Since Turkey is dependent on other countries in obtaining natural gas, price fluctuation in natural gas also reflects to the day ahead market electricity price. Market bidders, both in demand and supply side, has problem at that issue. Plant managers can calculate their costs. Since Turkish day ahead market structure does not let bidders to see other market participants' bids, market participants are not able to make bids effectively. Moreover, there is no other chance to change submitted bids. When market participant submits its own bid, it does not have right to change the bid. However, they do not know at which price they should sell the electricity in abnormal conditions, such as natural gas price fluctuation, climate changes. Thus, a locked cycle emerges and prices becomes fluctuating in bids, resultant prices as well. That is application procedure of Turkish day ahead market which blocks occurrence of day ahead reference market price. [20]

Another problem in Turkish day ahead market system in application process is that upper limit of bids are not well defined and calculated regarding economical and physical structures, especially during extreme conditions. However, in reality, prices may increase more than the upper system limits which results with uncertainty of resultant market prices. Therefore, supply bid prices increase sharply and day ahead electricity prices increase undeservedly.

Manipulation of day ahead market is problem for operation of day ahead market in that market participants can manipulate market prices. Since all market participants make their bids according to their marginal costs, seller market participants can make bids more than their marginal costs so that they can make more profit. There is not enough mechanism to control the bids of market participants; therefore plant owners may tend to fraud. The only mechanism is conducted by MFSC. In day time, right after bids are submitted, MFSC checks all bids. However, this is not feasible and effective. This is because bid checking operation of MFSC ends in only 1 hour. No other control cycle is injected into the system. Such cases bring higher prices than expected.

On December 2012, Competition Authority decided to investigate the market according to high prices occurred in day ahead market on November 2012. Nevertheless, prices were settled at maximum limits. This could be a hint for fraud manipulation in that market participants could have a secret agreement to settle the prices. Settling prices to the highest level is based on the bids. Such a manipulation can be done by decreasing production capacity of a plant intentionally, as well as creating artificial demand problems among market participants. This means, a market participant is using its own market power in illegal way by manipulating the competitive prices. Such a crisis occurred on 2001, in California, USA by resulting for long duration of time, scarcity of electricity emerged. However, in Turkey, on November 2012, Competition Authority concluded that, dramatic increment in market price was not due a fraud manipulation by market participants. This crisis was due to the plants which are operated by natural gas. At this period, natural gas prices were

increased, so BOTAŞ needed to make an increase in price natural gas price while selling to plants. Therefore, some plants needed to decrease their production capacity and as a result supply amount of power was decreased. Thus, electricity prices increased sharply. However, this was not due to the manipulation.

5.4 Criticisms on Turkish Day Ahead Market Model and Its Application

The main aim of liberalization is to decrease the market prices of electricity with supplying much quality electricity energy to the system in a competitive market. Turkey has been amending laws and legislations so as to liberalize wholesale electricity trading since 2001, starting with vertical unbundling of electricity generation, transmission and distribution. This would lead decreasing of electricity prices which reflects to both wholesalers and end users. 2009 is the milestone for electricity trading in Turkey. Starting from 2009, Turkey has been utilizing day ahead balancing system. 2011 December is the starting point of day ahead market in Turkey. It is obvious Turkey has been progressing in last 12 years in wholesale electricity trading with amendments.

One of the critical changes is adopting the Bilateral Contracts to the electricity trading. Bilateral contract is the market in which supply and demand sides are free to sign an energy trading contract for future trading. In case of finding no counterparty and no appropriate contract, market participants have second chance for energy balancing. Day ahead market is the market in which market participants did not sign contract for energy trading. In Turkey, as 2013, 65% of electricity trading market is based on Bilateral contracts, 30% of electricity trading market is based on day ahead markets. Moreover, only 55% of market participants trade over day ahead markets. Both market participant percent and volume of day trading in market depicts that Turkey have some problems and criticisms over its day ahead market trading system.

Day ahead market is based on competitive market. Competitive market needs to have suppliers and demanders both participate in market with their bids as desired. In a competitive market, all market participants must compete in fair manner, without having an advantage over others. In Turkey, one of the criticisms over day ahead market system is the existence of state governed plants. Around 45% of generation plants are under state control as 2013. Thus, cross subsidization emerge and market structure is not fully liberalized, keeping in mind that market is governed by state owned company TEİAŞ. State owned generators tan an advantageous position over private ones in market in competition which destroys basic principle of market. Therefore, private generators hesitate in attending day ahead market.

Turkish day ahead market is structured on uniform pricing trading. Each and every market participant has only 1 chance for bidding. Market participants do not aware the bids of other participants since bids are not published at bidding process. Criticisms start this point that such a model does not lead transparency in bidding. Since transparency is not fully gathered,

competitive market do not work as desired according to criticisms which reflect to the bidding prices and as result, market clearing price of electricity.

The other criticism about Turkish day ahead market system is about non occurrence reference price of electricity as result of market. Generating reference price for electricity is one fundamental aim of day ahead market. In Turkish day ahead market, generators aware their production costs, on the other hand, plant companies do not know around how much they should sell produced amount of electricity. Unknown price reveal bid fluctuations and as result fluctuations in day ahead market clearing price. Without a reference price of electricity, companies may not be able to make their risk managements in both short term and long term. For long term, this is because while signing bilateral contracts, they do not have a reference electricity price. Thus, huge amounts of losses may emerge as a result of long term contracts. Risk management in long terms becomes difficult. Short term risk management is also related with non-occurrence of reference market price. Since companies do not know how much price they should bid for correspondence amount of energy, hence, companies can have losses economically. Thus, generator companies may not be able to have successful risk managements.

Turkish day ahead market model is open to manipulations on day ahead market. During system design and application, no mechanism is added to Turkish electricity day ahead market which leads full control is over regulator. If there were any control mechanism automatically which warn market in case of manipulations, system would be purified against manipulations. In current system, regulator should check all companies whether they are manipulating market or not. However, in practice it is not fully applicable since market contains hundreds of buying and selling companies. Market can be manipulated in two ways. Firstly, market can be manipulated by physical withholding. Two or more generators can have an agreement on production capacity of each plant. Assume that 5 companies agree such physical withholding. 4 of them decrease their production capacity intentionally; however, they declare reason of withholding as maintenance, repair or technical problems. In this case 1 company supply the most energy system, thus energy prices depend mostly on only 1 company, leads increasing of supply prices and as a result, increasing of market clearing price. As a result, the huge profit is divided in agreed generator companies. Even with two companies which have market power, physical withholding can occur in market. Turkish day ahead market is open to such physical withholding manipulations. Second manipulation type can occur in Turkish day ahead market is, Economical Withholding. Economical Withholding provides flexibility to generator companies on bidding prices during extreme conditions such as hot weather, humidity. In such cases, since there is no market splitting in Turkey and there are physical limits on the transmission grids, if a generator company is aware that energy is supplied to system mostly by it, such a supplier can increase prices sharply. It can represent the costs more than as it has. Therefore, supply bids of electricity increase and as a result, market clear price is increased by such an economical manipulation. Turkish system have also tendency to be exposed to such economical withholding. However, many modern day ahead market mechanisms detect and warn system operator automatically. Modern systems have also limitations on physical

withholding for market manipulations. For example, ISO New England system describes physical withholding and economical withholding limits and rules in Market Rule Law. Unfortunately, Turkish day ahead market does not have such predefined thresholds. Accenture Company offers that market should have a system in which marginal costs of generators are defined in system so that day ahead market can have a reference price for day ahead market. Regulator can make amendments on bidding prices such as describing limits on bids. As an example, when temperature is above x degrees, demand is above y ; demand may not exceed price m , as well as the resultant day ahead market price cannot exceed $c\%$ of reference price. In the cases bids or results exceed the thresholds, system should give an alert and warn regulator against market manipulations. Such automatic systems exist in most day ahead market models all around the world. This would detect market manipulations and as a result, market prices decrease. Unfortunately, Turkish day ahead market system does not have such an automatic control. [20]

Another criticism is about the regulatory authority. European Union reporters reported that electrical trading regulatory authority needs to be strengthened. Regulatory authority does not have full independence, according to the European Union Progress Report, 2012. This situation also damages fair competition base in whole electricity trading, similarly, day head day.

CHAPTER 6

SOFTWARE APPLICATION OF DAY AHEAD MARKETS IN TURKEY

6.1 User Manual of Software Application

A Software is developed based on MATLAB language for this thesis. In order to use written software, Microsoft Office Excel Application and MATLAB have to be installed on computer.

Using of program starts with Microsoft Excel. Operator should enter the bid amount of price in TL/MWh and bid amount of quantity of power in MW in a specific time.

User should enter the bid's related time interval in "TIME INTERVAL" column. In "COMPANY NAME" column, user enters the name of company. All buying and selling bid prices should be in ascending order. For buying bids, user should enter positive values to the related quantity (MW) column. Conversely, for selling bids, user should enter negative values to the related quantity (MW) column. The important thing in excel is, for decimals, "," has to be used instead of ".". Software program is capable of accepting both buying and selling bids for one company in a time interval. Moreover, software code can accept various kinds of time intervals and companies at each time interval.

In MATLAB code, user should be careful the imported Excel file name. Both Excel file name and imported file should be the same as seen in Figure 28 and Figure 29, with red squares. After running the code in MATLAB, software code imports data entered in Excel and asks user for the upper price bid limit in TL/MWh. This upper price limit is decided and announced by MFSC. For this software, user enters upper bid limit when user runs software. In main screen it is asked to enter upper bid limit as in Figure 30.

	A	B	C	D	E	F	G	H	I
1						0			
2	TIME INTERVAL	COMPANY NAME							
3	00:00-01:00								
4		A ŞİRKETİ							
5			TL/MWh	0	35	35,01	55	55,01	500
6			MW	60	60	40	40	20	20

Figure 28 Bids entered in excel for developed MATLAB software

```

Editor - C:\Users\300e5a\Desktop\MATLAAAAB\supply_demand_v3_excel_integration.m*
File Edit Text Go Cell Tools Debug Desktop Window Help
This file uses Cell Mode. For information, see the rapid code iteration video, the publishing video, or help.
1 - upper_bid_limit=input('Maximum allowable upper bound limit in TL/MWh: ');
2 - [excel_data,strings]=xlsread('bids2.xls','Sayfal');

```

Figure 29 Developed MATLAB Software - Excel integration

```

Command Window
New to MATLAB? Watch this Video, see Demos, or read Getting Started.
fx Maximum allowable upper bound limit in TL/MWh:

```

Figure 30 MATLAB screen after running code

After entering upper bid limit in TL/MWh, user presses “ENTER” button and calculation starts according to written software. Software program is capable of optimizing the dispatch with guarantying supply demand balance in physically and economically according to Chapter 4.

After calculations, run code generates excel file, called “results.xls” in Excel format. Inside “results.xls” file, Market Clearing Price of Day Ahead Market shown in KPTF column for each hour period, in TL/MWh, as shown in Figure 31. Attendants are shown in “COMPANY NAME” column in Figure 31. Excel file results.xls depicts each market participants’ buying or selling quantity of energy in a specific time interval. – demonstrates, supplying energy, whereas + demonstrates receiving energy. Time periods are shown in “TIME INTERVAL” column, as in Figure 31. Excel file results.xls also depicts each market participants’ total receivable or total payments in a specific time interval in TL. Here, - demonstrates payments, conversely, + demonstrates receivables.

	A	B	C	D	E	F
1						
2						
3						
4	TIME INTERVAL	KPTF	COMPANY NAME	MWh	TL	
5	00:00-01:00	47,495	A	40	-1899,8	
6	00:00-01:00	47,495	B	20	-949,9	
7	00:00-01:00	47,495	C	-60	2849,7	
8	00:00-01:00	47,495	D	0	0	
9	01:00-02:00	42,495	A	40	-1699,8	
10	01:00-02:00	42,495	B	-40	1699,8	
11	02:00-03:00	42,495	A	40	-1699,8	
12	02:00-03:00	42,495	C	-40	1699,8	

Figure 31 Results of written MATLAB software in excel

For checking the supply demand balance for each interval, it can be computed by adding rows of MWh and TL separately. They should be 0 at each time interval. These are shown in (Equation 6-1) and (Equation 6-2).

For amount of quantity in MWh, system must obey the following rule:

$$\sum SAM = \sum SSM \quad (\text{Equation 6-1})$$

Similarly, there should be no extra or less money on the system after balancing. This means received and paid prices should be equal for each time interval as follows:

$$\sum SAT = \sum SST \quad (\text{Equation 6-2})$$

After running code, code generates supply demand curves for all time intervals separately as shown in Figure 32.

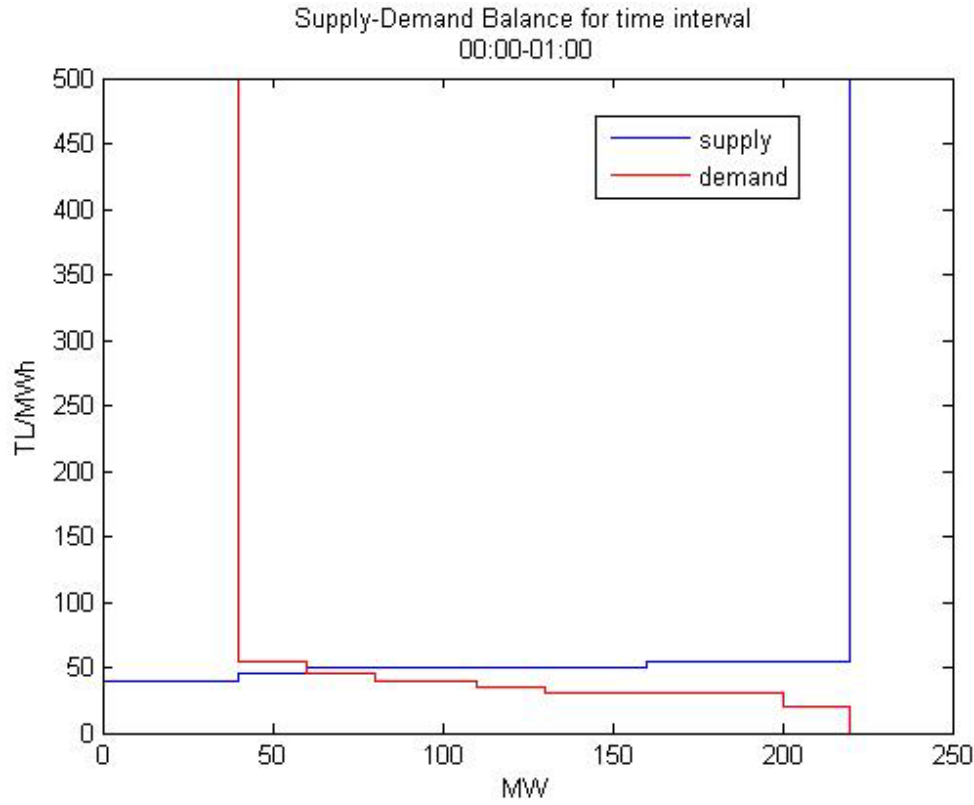

Figure 32 Supply-Demand Balance output of developed software

6.2 Examples on Day Ahead Market Using Uniform Pricing Model

As explained in Chapter 4 and Chapter 5, Turkish day ahead market system is based on Uniform Pricing Model. One of the critical methods of uniform pricing model is market splitting. However, Turkey does not apply market splitting currently. Therefore only 1 price occurs in system that is known as KPTF. In this part, 2 examples will be shown. In first example, for only 1 hour period, day ahead market balance is shown. In second example, multiple hours balance is depicted.

6.2.1 Example for 1 Hour Time Interval

There are 4 market participants with company names, “Company A”, “Company B”, “Company C” and “Company D”. These companies’ bid for time interval 15:00-16:00 is examined in this example. For this example, it is assumed that system operator announces upper bid limit as 200 TL/MWh. In the examples in this chapter and throughout thesis, - sign in MW column in bids denotes selling energy, whereas + indicates purchasing of electricity. Portfolios of Company A, Company B, Company C, Company D are explained primarily, then calculations are performed and results are explained throughout this section.

Company A is wholesaler. Thus, this company bids for buying energy. Company A has bidding and load information as shown in Table 6.

Table 6 Portfolio of Company A for Chapter 6.2.1 [21]

Company A	Load(MW)	Economical Price of Electricity (TL/MWh)	Description
Base Load	40		Independent of price
Adjustable Load	20	35 TL/MWh	It is not economical when price is above 35 TL/MWh, thus company decrease 20 MW of power.
Adjustable Load	20	55TL/MWh	Heating: When price is above 55TL/MWh, company can utilize different heating source instead of electricity. Thus, electrical load decrease 20 MW.
TOTAL	80		
Bilateral Contracts	20		Buying electricity via bilateral contract

According to the Table 6, Company A has already signed bilateral contract with a seller company which has order of buying 20MW power. This company has a fixed 40MWh load at specific time interval, i.e. 15:00-16:00. Fixed load is independent of price of electricity. However, 20MWh is obtained by bilateral contracts. Thus, Company A needs to purchase minimum of 20MWh more at this time interval. Formulation is depicted in (3). 20MWh of energy can be purchased independent of price. Whatever day ahead market price is, company is ready to buy 20MWh energy.

Base Load Amount–Bilateral Contract Amount = Min. Energy has to be taken via DAM

According to Company A, it is feasible to purchase 20MWh more electricity if the resultant day ahead market price is below 35TL/MWh. Thus Company A can purchase;

$$20\text{MWh} + 20\text{MWh} = 40\text{MWh} \text{ if } KPTF \leq 35\text{TL/MWh}$$

Company A is ready to purchase 20MWh electricity more if price is below 55TL/MWh. This is because of economical reasons. Company concludes that, it can use another sources for heating if price is above 55TL/MWh. Hence;

$$40\text{MWh} + 20\text{MWh} = 60\text{MWh} \text{ if } KPTF \leq 55\text{TL/MWh}$$

Thus, bids of Company A are tabularized as in Table 7;

Table 7 Company A bids for Chapter 6.2.1

Price, (TL/MWh)	0	35	35.01	55	55.01	60	80	200
Company A, (Buyer) Quantity (MW)	60	60	40	40	20	20	20	20

Company B has the following Contracts and schedule as in Table 8 [21].

Table 8 Portfolio of Company B for Chapter 6.2.1 [21]

Company B	Load(MW)	Economical Price of Electricity (TL/MWh)	Description
Base Load	80		Independent of price
Adjustable Load	0		
TOTAL	80		
Bilateral Contracts	60		Buying electricity via bilateral contract

According to the Table 8 Company B has signed bilateral contract with a seller company. Company B purchase energy via bilateral contract with an amount of 60MW. Thus, at this specific time interval, 15:00-16:00, Company B obtains 60MWh energy from bilateral contract. However, Company B is retail Seller Company and it has a load of 80 MWh between 15:00-16:00 for the next day. Since 60MWh is obtained via bilateral contract:

$$80\text{MWh} - 60\text{MWh} = 20\text{MWh} \rightarrow \text{Independent of price}$$

Since 20MWh more energy is needed, Company B decides to participate in day ahead market for 20MWh. Moreover, Company B announces that price is not important for this 20MWh lack of power. It is ready to purchase it at any price. Hence, resultant bid table becomes as in Table 9.

Table 9 Company B bids for Chapter 6.2.1

Price, (TL/MWh)	0	200
Company B, (Buyer) Quantity (MW)	20	20

Company C is auto producer. Hence it both produces and consumes energy. Bidding strategy of Company C is depicted in Table 10.

Table 10 Portfolio of Company C for Chapter 6.2.1 [21]

Company C	Capacity (MW)	Marginal Cost (TL/MWh)	Description
Base Load	40		Independent of price
Production Facility 1	20	20 TL/MWh	Production is profitable when KPTF is greater than 20 TL/MWh
Production Facility 2	20	30 TL/MWh	Production is profitable when KPTF is greater than 30 TL/MWh
Production Facility 3	40	40 TL/MWh	Production is profitable when KPTF is greater than 40 TL/MWh
Production Facility 4	20	45 TL/MWh	Production is profitable when KPTF is greater than 45 TL/MWh
Production Facility 5	60	55 TL/MWh	Production is profitable when KPTF is greater than 55 TL/MWh
TOTAL	120		

Company C has a base load of 40MWh between 15:00-16:00. This company decides to purchase 40MWh independent of price.

Table 10 explains that production facilities changes according to their marginal costs.

If KPTF is greater or equal to 20TL/MWh, company decides to operate Production Facility 1. Thus Company C has;

$$40\text{MWh} - 20\text{MWh} = 20\text{MWh energy demand if } KPTF \geq 20\text{TL/MWh.}$$

If KPTF is greater or equal to 30TL/MWh, company decides to operate Production Facility 1 and 2. Thus Company C has;

$$40\text{MWh} - (20 + 20)\text{MWh} = 0 \text{ energy need or supply if } KPTF \geq 30\text{TL/MWh.}$$

If KPTF is greater or equal to 40TL/MWh, company decides to operate Production Facility 1, 2 and 3. Thus Company C has;

$$40\text{MWh} - (20 + 20 + 40)\text{MWh} = -40\text{MWh energy surplus can be sold if } KPTF \geq 40\text{TL/MWh.}$$

If KPTF is greater or equal to 45TL/MWh, company decides to operate Production Facility 1, 2, 3 and 4. Thus Company C has;

$$40\text{MWh} - (20 + 20 + 40 + 20) = -60\text{MWh energy surplus can be sold if } KPTF \geq 45\text{TL/MWh.}$$

If KPTF is greater or equal to 55TL/MWh, company decides to operate Production Facility 1, 2, 3, 4 and 5. Thus Company C has;

$$40\text{MWh} - (20 + 20 + 40 + 20 + 60)\text{MWh} = -120\text{MWh energy surplus can be sold if } KPTF \geq 55\text{TL/MWh.}$$

However, for all price levels, Company C has a load of 40MWh. Thus, 40MWh is subtracted at each price step in Table 11.

Gathering the Table 10 portfolio of Company C, yields Table 11 as follows:

Table 11 Company C bids for Chapter 6.2.1

Price, (TL/MWh)	0	19.99	20	29.99	30	39.99	40	44.99	45	54.99	55	200
Company C, (Buyer + Seller)	40	40	20	20	0	0	-40	-40	-60	-60	-120	-120
Quantity (MW)												

Company D is a production company which has 4 plants. This company has already signed bilateral contract. According to bilateral contract, Company D sells 100 MW of power. However, plant has plants and has more production capacity between 15:00-16:00. Thus, Company D decides to participate in day ahead market to sell surplus electricity. On the other hand, Company D calculates profitability of production and get some results. Then, Company D outlines the portfolio as in Table 12.

Table 12 Portfolio of Company D for Chapter 6.2.1 [21]

Company D	Capacity (MW)	Marginal Cost (TL/MWh)	Description
Plant 1	50	30 TL/MWh	Production is profitable when KPTF is greater or equal to 30 TL/MWh
Plant 2	30	40 TL/MWh	Production is profitable when KPTF is greater or equal to 40 TL/MWh
Plant 3	20	45 TL/MWh	Production is profitable when KPTF is greater or equal to 45 TL/MWh
Plant 4	50	50 TL/MWh	Production is profitable when KPTF is greater or equal to 50 TL/MWh
TOTAL	150		
Bilateral Contracts	100		Selling electricity via bilateral contract

Table 12 demonstrates production facilities changes according to their marginal costs. According to the portfolio of Company D, production is feasible only when marginal price of electricity is greater or equal to 30TL/MWh. However, pre-signed bilateral contract orders that Company D has to supply 100MWh amount of energy between 15:00-16:00. Hence, if KPTF occurs smaller than 30TL/MWh, D Company decides to buy electricity from day ahead market, and send energy to contractors. Hence;

If KPTF is smaller than 30TL/MWh, company decides to purchase 100MWh of energy from market without operating its plants.

If KPTF is greater or equal than 30TL/MWh, company decides to operate Plant 1. Thus Company C has;

$$100\text{MWh} - 50\text{MWh} = 50\text{MWh energy demand if } KPTF \geq 30\text{TL/MWh}.$$

If KPTF is greater or equal than 40TL/MWh, company decides to operate Plant 1 and 2. Thus Company C has;

$$100\text{MWh} - (50 + 30)\text{MWh} = 20\text{MWh energy demand if } KPTF \geq 40\text{TL/MWh}.$$

If KPTF is greater or equal than 45TL/MWh, company decides to operate Plant 1, 2 and 3. Thus Company C has;

$$100\text{MWh} - (50 + 30 + 20)\text{MWh} = 0 \text{ energy need or supply if } KPTF \geq 40\text{TL/MWh}.$$

If KPTF is greater or equal to 50TL/MWh, company decides to operate all plants 1, 2, 3 and 4. Thus Company C has;

100MWh – (20 + 20 + 40 + 20 + 50)MWh = -50MWh energy surplus can be sold if KPTF >= 50TL/MWh.

Gathering the portfolio of Company C, yields Table 13 as follows:

Table 13 Company D bids for Chapter 6.2.1

Price, (TL/MWh)	0	29.99	30	39.99	40	44.99	45	49.99	50	200
Company D, (Buyer + Seller)	100	100	50	50	20	20	0	0	-50	-50
Quantity (MW)										

Table 7, Table 9, Table 11, Table 13 are inserted into bids5.xls file as bids of Company A, Company B, Company C, Company D for an hour between 15:00-16:00. Figure 33 depicts bids5.xls file.

After obtaining bids5.xls, MATLAB software is run by entering the upper limit bound as 200TL/MWh. Written MATLAB code gives the supply demand curve as in Figure 34. As one can observe from the curve, the intersection point between supply and demand curves determines the quantity and market price of electricity, KPTF. However, in Figure 34, it is observed that intersection of supply and demand occurs at more than 1 market price at a fixed quantity level. Hence, mid point is regarded as KPTF of overall system.

Software also generates Excel file results.xls which is depicted in Figure 35.

According to results.xls, it is optimized that system is in balance when market price, KPTF, is 47.495TL/MWh. Moreover, results.xls demonstrates that,

Company A will receive 40MWh amount of energy.

Company B will receive 20MWh amount of energy.

Company C will sell 60MWh amount of energy.

Company D will neither receive nor sell energy to the system.

Total payments and receivables are as follows:

Company A will pay:

$$SAT_{t,p,u,r} = SAF_{t,p,u,r} \times SAM_{t,p,u,r}$$

$$SAT = 47.495 \times 40 = 1899.8 \text{ TL}$$

Company B will pay:

$$SAT_{t,p,u,r} = SAF_{t,p,u,r} \times SAM_{t,p,u,r}$$

$$SAT = 47.495 \times 20 = 949.9 \text{ TL}$$

Company C will receive:

$$SST_{t,p,u,r} = SSF_{t,p,u,r} \times SSM_{t,p,u,r}$$

$$SST = 47.495 \times 60 = 2849.7 \text{ TL}$$

Company D will neither receive nor pay for energy.

As day ahead market aims, according to the results, system is in supply and demand balance. Since Equation 6-1 claims:

$$\sum SAM = \sum SSM \text{ (Equation 6-1)}$$

For this example:

$$40\text{MWh} + 20\text{MWh} = 60\text{MWh}$$

Equation 6-1 is hold.

Similarly, there should be no extra or less money on the system after balancing. This means received and paid prices should be equal for each time interval as in Equation 6-2:

$$\sum SAT = \sum SST \text{ (Equation 6-2)}$$

For this example:

$$1899.8 \text{ TL} + 949.9 \text{ TL} = 2849.7 \text{ TL}$$

Equation 6-2 is hold.

Therefore, system is in balance and day ahead market balances whole system one day ahead auction trading.

Before attending day ahead market, as Table 6 depicts, Company A has need of minimum 20MWh. As a result, Company A received 40MWh energy, thus there is no scarcity of electricity for this company. Thus, portfolio of Company A is balanced.

Before attending day ahead market, as Table 8 depicts, Company B has need of fixed 20MWh. As a result, Company B received 20MWh of energy, thus there is no scarcity of electricity for this company. Thus, portfolio of Company B is balanced.

Before attending day ahead market, as Table 10 depicts, Company C has need of minimum 40MWh. There is no production obligation for Company C. Production choice is dependent on result of KPTF according to portfolio. As a day ahead market result, Company C has to give 60MWh to the system. Since, it has need of extra fixed 40MWh; Company C has to produce 100MWh. In order to produce 100MWh, Company C must operate Production Facilities 1, 2, 3 and 4. Running of Production Facilities 1, 2, 3, 4 also satisfies the bid

requirement in that Company C decide to operate Production Facilities 1, 2, 3, 4 together when KPTF is smaller than 55TL/MWh. Thus, there is no scarcity of electricity for this company and portfolio is balanced. .

Before attending day ahead market, as Table 12 depicts, Company D has need of minimum 100MWh because of bilateral contract. There is no production obligation for Company D, yet it should fulfill the requirements of bilateral contract. Thus, balancing portfolio depends on result of KPTF. As a day ahead market result, Company D should neither give nor receive energy to the system. However, since KPTF is 47.95TL/MWh, Company D power on plants 1, 2, and 3 in its portfolio in order to meet 100MWh bilateral contract demand amount of energy. This also satisfies bidding strategy of Company D. Thus, portfolio of Company A is balanced.

Microsoft Excel - bids3

Dosya Düzen Görünüm Ekle Biçim Araçlar Veri Pencere Yardım

Anal Tur

Yardım için sor

	A	B	C	D	E	F	G	H	I	J	K	L	M	N	O	P
1					example 5.1	0										
2	TIME INTERVAL	COMPANY NAME														
3	15:00-16:00	A														
4			TL/MWh	0	35	35.01	55	55.01	60	80	200					
5			MW	60	60	40	40	20	20	20	20					
6																
7		B														
8			TL/MWh	0	200											
9			MW	20	20											
10																
11		C														
12			TL/MWh	0	19.99	20	29.99	30	39.99	40	44.99	45	54.99	55	200	
13			MW	40	40	20	20	0	0	-40	-40	-60	-60	-120	-120	
14																
15		D														
16			TL/MWh	0	29.99	30	39.99	40	44.99	45	49.99	50	200			
17			MW	100	100	50	50	20	20	0	0	-50	-50			
18			periyot sonu													

Figure 33 Bids entered to developed software in xls format

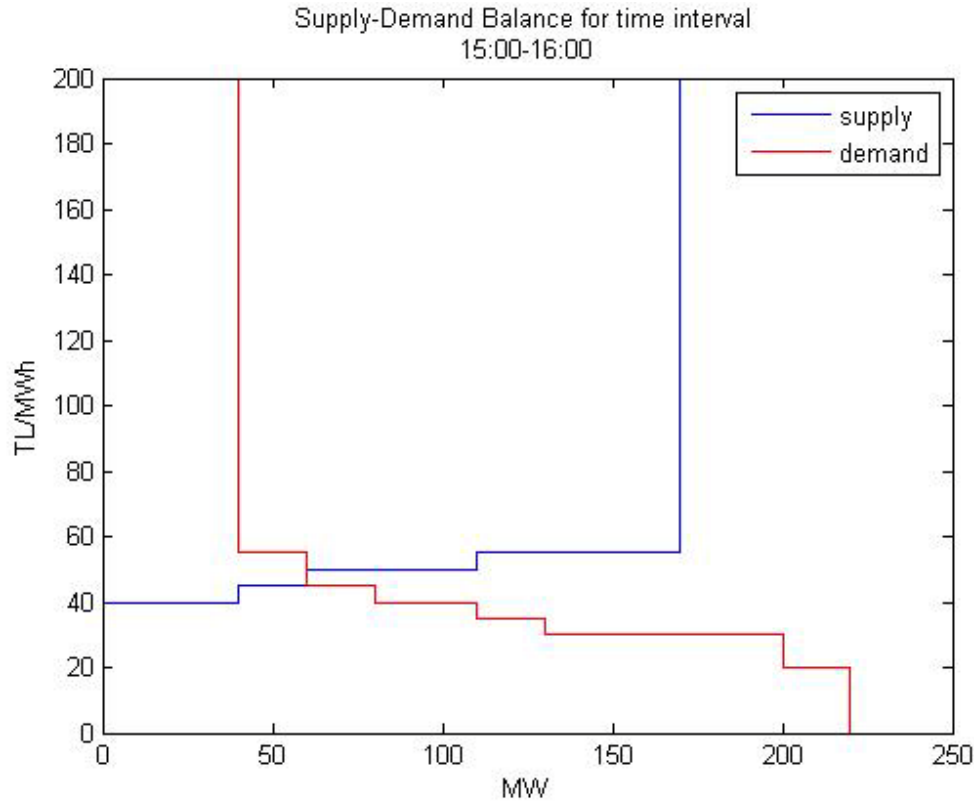

Figure 34 Supply Demand Balance for Example 5.2.1

Microsoft Excel - results							
Dosya Düzen Görünüm Ekle Biçim Araçlar Veri Pencere Yardım							
I23							
	A	B	C	D	E	F	G
1							
2							
3							
4	TIME INTERVAL	KPTF	COMPANY NAME	MWh	TL		
5	15:00-16:00	47,495	A	40	-1899,8		
6	15:00-16:00	47,495	B	20	-949,9		
7	15:00-16:00	47,495	C	-60	2849,7		
8	15:00-16:00	47,495	D	0	0		
9							

Figure 35 Excel output of developed software for Example 5.2.1

6.2.2 Example for 1 Hour Time Interval with Market Splitting

In Chapter 6.2.1, example was not based on market splitting. In this section, example based on market splitting and affects of market splitting on market prices and transmission congestion is examined. Example is for the time interval between 15:00-16:00 for the next day as in Chapter 6.2.1. However, Turkey does not implement market splitting in day ahead market, and this chapter demonstrates the application and advantages of market splitting which can be useful for Turkey in future.

The companies entering the day ahead auction is as the same as in Chapter 6.2.1. Portfolio and bids of companies are also as the same as in Chapter 6.2.1. Hence, Table 6, Table 8, Table 10, Table 12 are valid. Since portfolio of companies is valid, similarly, Table 7, Table 9, Table 11 and Table 13 is used for example of this chapter.

The only difference to the Chapter 6.2.1 is market splitting, that is pricing is based on regional supply and demands. Whole region in Chapter 6.2.1 is divided into 2 regions, and the regional companies are shown in Figure 36.

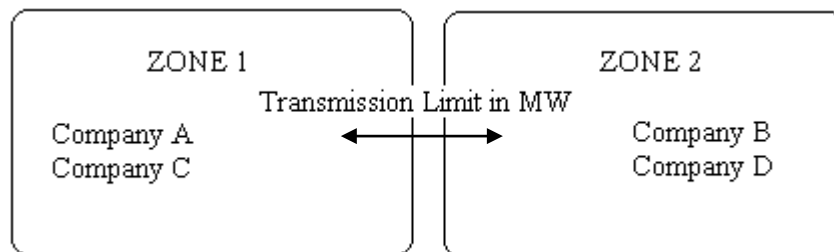

Figure 36 Zonal energy transmission among regions

Table 14 shows portfolio of Company A which is in Region 1.

Table 15 shows portfolio of Company B which is in Region 2.

Table 16 shows portfolio of Company C which is in Region 1.

Table 17 shows portfolio of Company D which is in Region 2.

Table 14 Portfolio of Company A for Chapter 6.2.2 [21]

Company A	Load(MW)	Economical Price of Electricity (TL/MWh)	Description
Base Load	40		Independent of price
Adjustable Load	20	35 TL/MWh	It is not economical when price is above 35 TL/MWh, thus company decrease 20 MW of power.
Adjustable Load	20	55TL/MWh	Heating: When price is above 55TL/MWh, company can utilize different heating source instead of electricity. Thus, electrical load decrease 20 MW.
Bilateral Contracts	20		Buying electricity via bilateral contract

Table 15 Portfolio of Company B for Chapter 6.2.2 [21]

Company B	Load(MW)	Economical Price of Electricity (TL/MWh)	Description
Base Load	80		Independent of price
Adjustable Load	0		
TOTAL	80		
Bilateral Contracts	60		Buying electricity via bilateral contract

Table 16 Portfolio of Company C for Chapter 6.2.2 [21]

Company C	Capacity (MW)	Marginal Cost (TL/MWh)	Description
Base Load	40		Independent of price
Production Facility 1	20	20 TL/MWh	Production is profitable when KPTF is greater than 20 TL/MWh
Production Facility 2	20	30 TL/MWh	Production is profitable when KPTF is greater than 30 TL/MWh
Production Facility 3	40	40 TL/MWh	Production is profitable when KPTF is greater than 40 TL/MWh
Production Facility 4	20	45 TL/MWh	Production is profitable when KPTF is greater than 45 TL/MWh
Production Facility 5	60	55 TL/MWh	Production is profitable when KPTF is greater than 55 TL/MWh
TOTAL	120		

Table 17 Portfolio of Company D for Chapter 6.2.2 [21]

Company D	Capacity (MW)	Marginal Cost (TL/MWh)	Description
Plant 1	50	30 TL/MWh	Production is profitable when KPTF is greater or equal to 30 TL/MWh
Plant 2	30	40 TL/MWh	Production is profitable when KPTF is greater or equal to 40 TL/MWh
Plant 3	20	45 TL/MWh	Production is profitable when KPTF is greater or equal to 45 TL/MWh
Plant 4	50	50 TL/MWh	Production is profitable when KPTF is greater or equal to 50 TL/MWh
TOTAL	150		
Bilateral Contracts	100		Selling electricity via bilateral contract

Firstly, the portfolios are entered to excel sheet as in Figure 33. Figure 38 is similar to Figure 33 with a difference, Figure 38 includes zones of companies in column C of excel sheet as labeled in red box.

Written MATLAB software imports the zonal bid data as in Figure 38 and makes the optimized dispatching. Transmission limit is entered as 10MW between Zone 1 and Zone 2, shown in Figure 37. Results are printed to the results.xls file as in Figure 39.

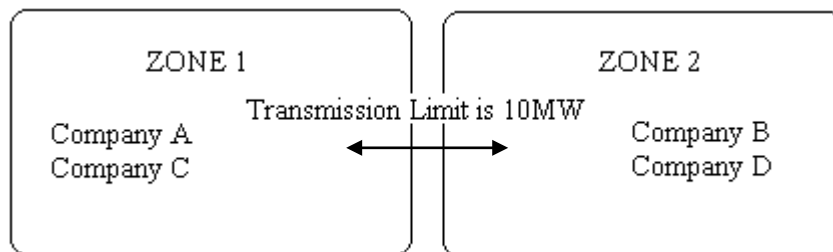

Figure 37 Transmission limit is 10MW among zones for example 5.2.2.

Column A depicts the related time interval. This column is important when day ahead market prices of all hours of day are calculated.

Columns B, C, D, E, F are the calculations when there is no market splitting. They are the result if there is no market splitting. On the other hand, columns G, H, I and J are the results for day ahead market with market splitting. Column B is the KPTF of system in TL/MWh. As seen from Figure 39, if there is no market splitting, market price would be 47.495

Microsoft Excel - bids6.spitting

Dosya Duzen Gorunum Ekle Bircim Araclar Veri Pencere Yardim

Q27

Yardim için soru yazın

	A	B	C	D	E	F	G	H	I	J	K	L	M	N	O	P
1				example			0									
2	TIME INTERVAL	COMPANY NAME	REGION													
3	15:00-16:00															
4		A	1.ZONE													
5				TL.MWh	0	35	35.01	55	55.01	500						
6				MWh	60	60	40	40	20	20						
7																
8		B	2.ZONE													
9				TL.MWh	0	500										
10				MWh	20	20										
11																
12		C	1.ZONE													
13				TL.MWh	0	19.99	20	29.99	30	39.99	40	44.99	45	54.99	55	500
14				MWh	40	40	20	20	0	0	-40	-40	-60	-60	-120	-120
15																
16																
17		D	2.ZONE													
18				TL.MWh	0	29.99	30	39.99	40	44.99	45	49.99	50	500		
19	periyot somu			MWh	100	100	50	50	20	20	0	0	-50	-50		
20																

Figure 38 Bids entered to MATLAB for Example 5.2.2

	A	B	C	D	E	F	G	H	I	J
1										
2										
3										
4	TIME INTERVAL	KPTF	COMPANY NAME	MWh	TL		REGION	NPTF	MWh	TL
5	15:00-16:00	47,495	A	40	-1899,8		1.ZONE	44,995	40	-1799,8
6	15:00-16:00	47,495	B	20	-949,9		2.ZONE	49,992	20	-999,84
7	15:00-16:00	47,495	C	-60	2849,7		1.ZONE	44,995	-50	2249,75
8	15:00-16:00	47,495	D	0	0		2.ZONE	49,992	-10	499,92
9										

Figure 39 Market results of Example 5.2.2 generated by developed software

NPTF1_zone1 =

44.9950

NPTF1_zone2 =

49.9920

Figure 40 Zonal market price results generated by developed software

TL/MWh. As the result, Company A receives 40MWh of energy, Company B receives 20MWh of energy, and Company C gives 60MWh of energy to the system. However, assuming that there is no market splitting; moreover, Company A and Company C are located in Zone 1; whereas Company B and Company D are located in Zone 2 where transmission limit of grids between Zone 1 and Zone 2 is 10 MW. In this case in Zone 1;

$$40\text{MWh} - 60\text{MWh} = -20\text{MWh surplus of energy}$$

In Zone 2;

$$20\text{MWh} + 0 = 20\text{MWh lack of energy}$$

It seems to that 20MWh of energy has to be transferred to the Zone 2 from Zone 1. However, transmission capacity is limited with 10 MW. Hence, maximum of 10MWh of energy can be transferred to the Zone 2 from Zone 1. As a result, 10MWh surplus of energy occur in Zone 1, whereas 10MWh scarcity of energy occur in Zone 2. Thus, day ahead market results with electricity scarcity in Zone 2. So, day ahead market does not handle transmission congestion without market splitting.

However, with market splitting, zonal pricing, there occur 2 prices, NPTF for Zone 1 and NPTF for Zone 2 in TL/MWh. If both zones are regarded as independent systems, the balancing of Zone 1 is as follows:

mcp1_zone1 =

42.4950

qty_zone1 =

40.0000

Figure 41 Balancing results for zone 1 in example 5.2.2 generated by developed software

In Figure 41, mcp1_zone1 variable indicates market clearing price of Zone 1 in TL/MWh if it is independent system. qty_zone1 variable indicates market balancing quantity in MW of Zone 1 if it is independent system. Figure 42 depicts supply demand curve of Zone 1 if it is regarded as independent system. Figure 42 confirms Figure 41 in that intersection of supply and demand curves are at (qty_zone1, mcp1_zone1)=(40, 42.495).

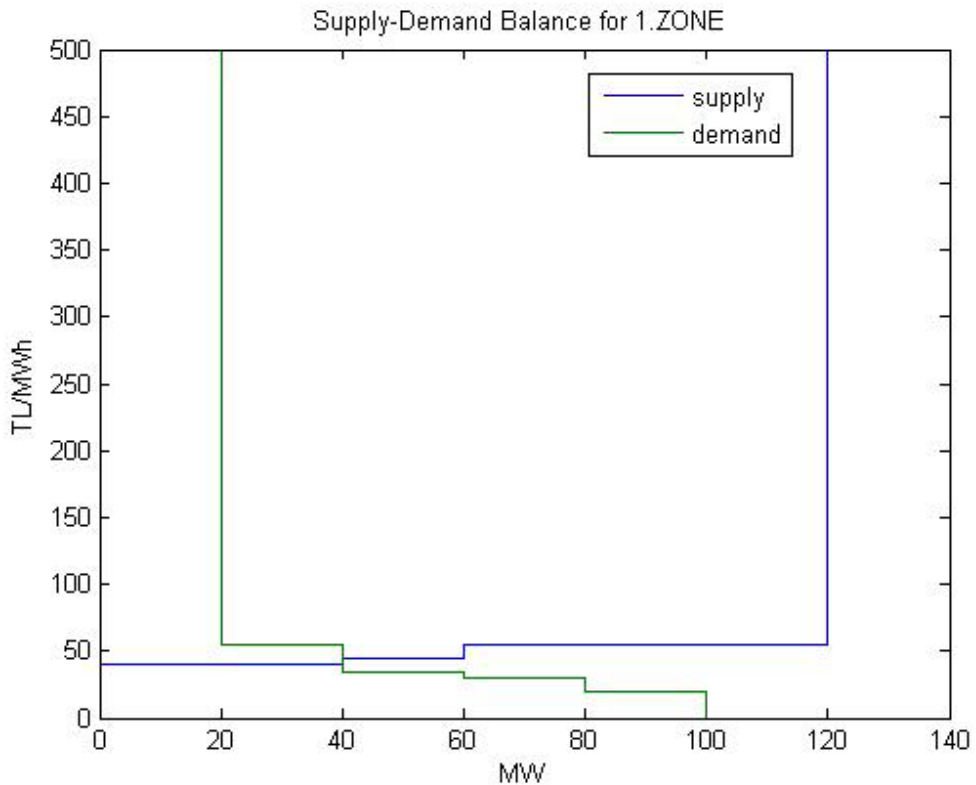

Figure 42 Supply demand balance graph of zone 1 in example 5.2.2

If both zones are regarded as independent systems, the balancing of Zone 2 is as follows:

mcp1_zone2 =

49.9940

qty_zone2 =

20.0000

Figure 43 Balancing results for zone 2 in example 5.2.2 generated by developed software

In Figure 43, mcp1_zone2 variable indicates market clearing price of Zone 2 in TL/MWh if it is independent system. qty_zone2 variable indicates market balancing quantity in MW of Zone 2 if it is independent system. Figure 44 depicts supply demand curve of Zone 2 if it is regarded as independent system. Figure 44 confirms Figure 43 in that intersection of supply and demand curves are at (qty_zone2, mcp1_zone2)=(20, 49.994)

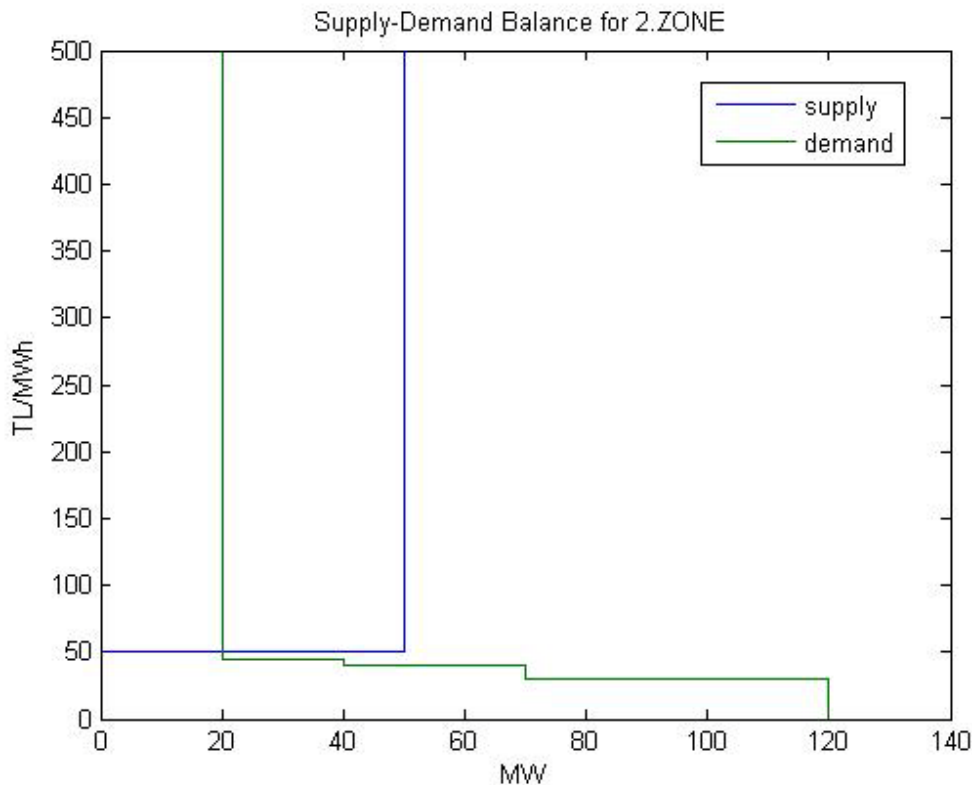

Figure 44 Supply demand balance graph of zone 2 in example 5.2.2

As a result of Figure 41 and Figure 43, zone 1 has smaller market clearing price if two zones are regarded as independent systems. This means Zone 1 can transmit energy to the Zone 2. By entering transmission capacity limit as 10 MW, after software implementation, for Zone 1;

$$40\text{MWh} - 50\text{MWh} = -10\text{MWh surplus of energy}$$

For Zone 2;

$$20\text{MWh} - 10\text{MWh} = 10\text{MWh lack of energy}$$

It results 10MWh of energy has to be transferred to the Zone 2 from Zone 1. In market splitting case, 10MWh of energy can be transferred to the Zone 2 from Zone 1 since transfer limit of grid is 10MW. As a result, balance is occurred in whole system. In both Zone 1 and Zone 2, there is neither surplus nor scarcity of electricity energy.

Figure 39, Colum I demonstrates how much energy has to be transferred by each company. According to Figure 39;

Company A receives 40MWh energy from system.

Company B receives 20MWh energy from system.

Company C transmits 50MWh energy from system.

Company D transmits 10MWh energy from system.

According to the results.xls, Column H, Zone 1 has market price, NPTF, 44.995TL/MWh, whereas Zone 2 has market price, NPTF, 49.992TL/MWh.

Total payments and receivables are as follows:

Company A will pay:

$$SAT_{t,p,u,r} = SAF_{t,p,u,r} \times SAM_{t,p,u,r}$$

$$SAT = 44.995 \times 40 = 1799.8 \text{ TL}$$

Company B will pay:

$$SAT_{t,p,u,r} = SAF_{t,p,u,r} \times SAM_{t,p,u,r}$$

$$SAT = 49.992 \times 20 = 999.84 \text{ TL}$$

Company C will receive:

$$SST_{t,p,u,r} = SSF_{t,p,u,r} \times SSM_{t,p,u,r}$$

$$SST = 44.995 \times 50 = 2249.75 \text{ TL}$$

Company D will receive:

$$SST_{t,p,u,r} = SSF_{t,p,u,r} \times SSM_{t,p,u,r}$$

$$SST = 49.992 \times 10 = 499.92 \text{ TL}$$

As day ahead market aims, according to the results, system is in supply and demand balance. Since Equation 6-1 claims:

$$\sum SAM = \sum SSM \quad (\text{Equation 6-1})$$

For this example:

$$40\text{MWh} + 20\text{MWh} = 50\text{MWh} + 10\text{MWh}$$

Equation 6-1 is hold.

There should be no extra or less money on the system after balancing without market splitting. However, with market splitting, since energy is in balance, but prices are differ from one region to another region, total received money and total paid money may be different. This difference of money is invested for infrastructure structure of grids between regions in order to increase capacity of grids. This means received and paid prices may not be equal for each time interval as in Equation 6-3:

$$GÖPG_s = \sum_{t=1}^n \left(\sum_{p=1}^m SAT_{t,p,s} - \sum_{p=1}^m SST_{t,p,s} \right) \quad (\text{Equation 6-3})$$

For this example:

$$\text{Total paid} = \sum SAT = 1799.8 + 999.84 = 2799.6 \text{ TL}$$

$$\text{Total received} = \sum SST = 2249.75 + 499.92 = 2749.7 \text{ TL}$$

$$\text{Hence, } GÖPG = \sum SAT - \sum SST = 49.9 \text{ TL}$$

This means there occur surplus of 49.9TL. This money is paid to market operator and market operator uses this money for improving transmission grids infrastructure between zones.

However, if transmission capacity between regions are given as 20MW as in Figure 45, pricing would be different.

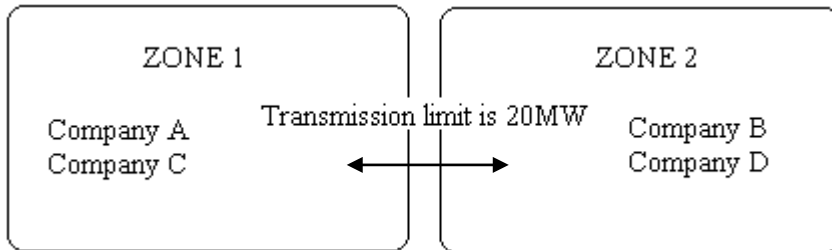

Figure 45 Transmission limit is 20MW among zones for example 5.2.2

In this case results are shown in Figure 46:

	A	B	C	D	E	F	G	H	I	J
1										
2										
3										
4	TIME INTERVAL	KPTF	COMPANY NAME	MWh	TL		REGION	NPTF	MWh	TL
5	15:00-16:00	47,495	A	40	-1899,8		1.ZONE	47,495	40	-1899,8
6	15:00-16:00	47,495	B	20	-949,9		2.ZONE	47,495	20	-949,9
7	15:00-16:00	47,495	C	-60	2849,7		1.ZONE	47,495	-60	2849,7
8	15:00-16:00	47,495	D	0	0		2.ZONE	47,495	0	0
9										

Figure 46 Market results of Example 5.2.2 with 20MW transmission limit among regions, generated by developed software

If both zones are regarded as independent systems, the balancing of Zone 1 is as follows:

$$\text{mcp1_zone1} =$$

$$42.4950$$

$$\text{qty_zone1} =$$

$$40.0000$$

Figure 47 Balancing results for zone 1 in example 5.2.2 with 20MW transmission limit, generated by developed software

In Figure 47, mcp1_zone1 variable indicates market clearing price of Zone 1 in TL/MWh if it is independent system. qty_zone1 variable indicates market balancing quantity in MW of Zone 1 if it is independent system. Figure 48 depicts supply demand curve of Zone 1 if it is regarded as independent system. Figure 48 confirms Figure 47 in that intersection of supply and demand curves are at (qty_zone2, mcp1_zone2) = (40, 42.495).

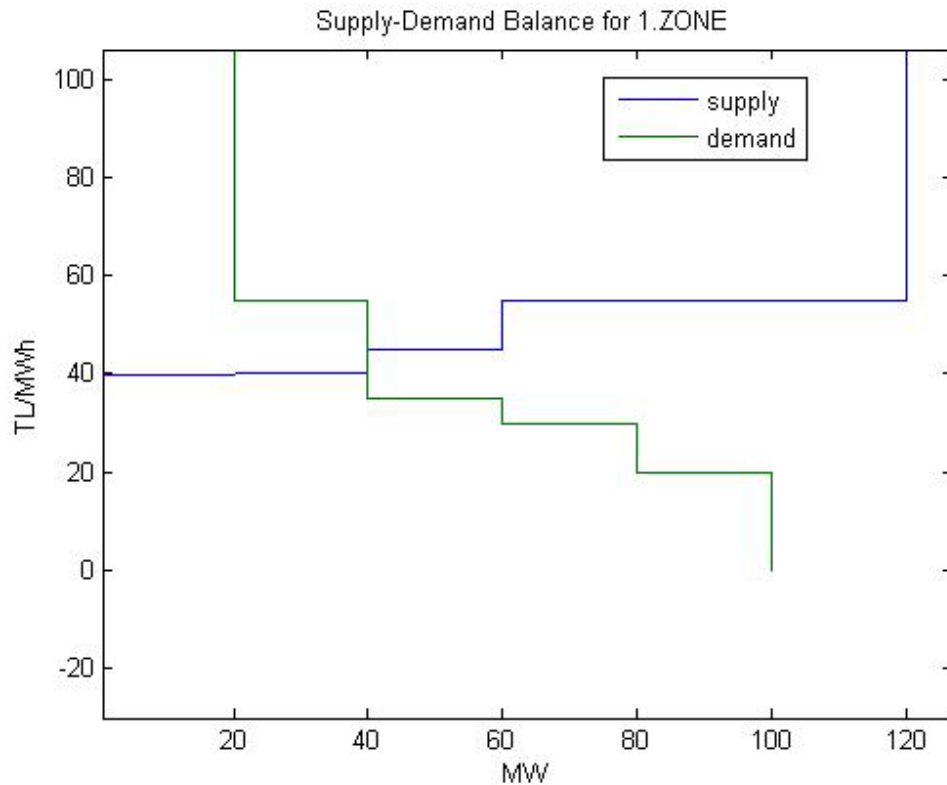

Figure 48 Supply demand balance graph of zone 1 in example 5.2.2 with 20MW transmission limit among regions

If both zones are regarded as independent systems, the balancing of Zone 2 is as follows:

```
mcp1_zone2 =
49.9940

qty_zone2 =
20.0000
```

Figure 49 Balancing results for zone 2 in example 5.2.2 with 20MW transmission limit, generated by developed software

In Figure 49, mcp1_zone2 variable indicates market clearing price of Zone 2 in TL/MWh if it is independent system. qty_zone2 variable indicates market balancing quantity in MW of Zone 2 if it is independent system. Figure 50 depicts supply demand curve of Zone 2 if it is

regarded as independent system. Figure 50 confirms Figure 49 in that intersection of supply and demand curves are at $(qty_zone2, mcp1_zone2)=(20, 49.994)$.

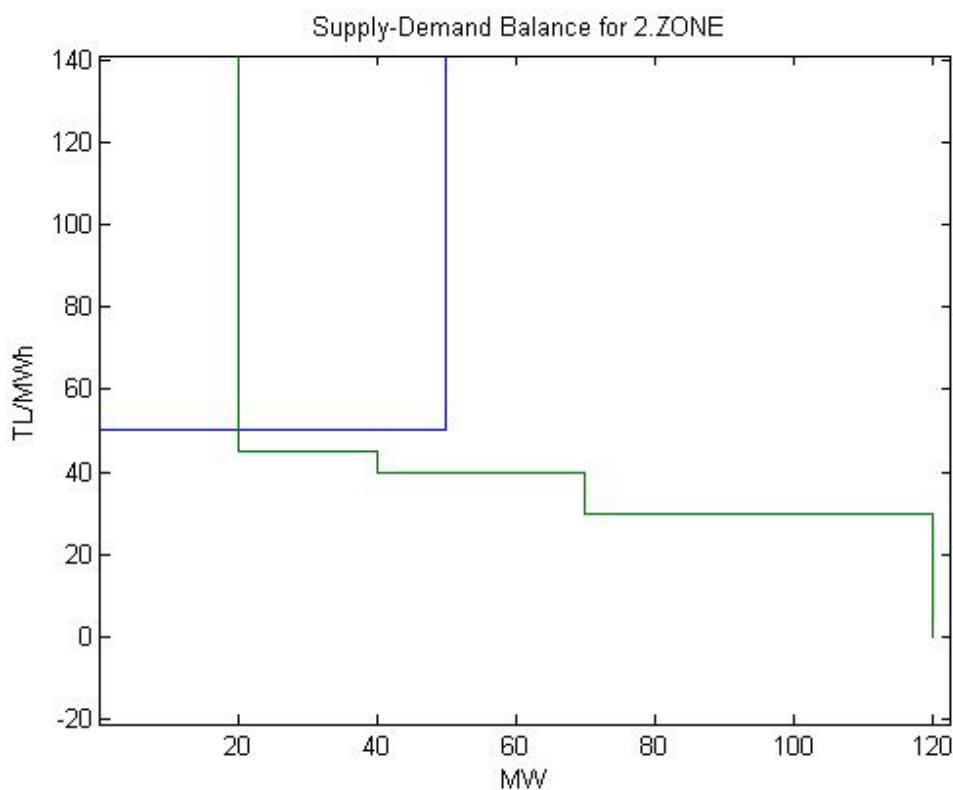

Figure 50 Supply demand balance graph of zone 2 in example 5.2.2 with 20MW transmission limit among regions

As a result of Figure 47 and Figure 49, zone 1 has smaller market clearing price if two zones are regarded as independent systems. This means Zone 1 can transmit energy to the Zone 2. By entering transmission capacity limit as 20 MW, after software implementation, for Zone 1;

$$40\text{MWh} - 60\text{MWh} = -20\text{MWh surplus of energy}$$

For Zone 2;

$$20\text{MWh} - 0\text{MWh} = 20\text{MWh lack of energy}$$

It results 20MWh of energy has to be transferred to the Zone 2 from Zone 1. In market splitting case, 20MWh of energy can be transferred to the Zone 2 from Zone 1 since transfer limit of grid is 20MW. As a result, balance is occurred in whole system. In both Zone 1 and Zone 2, there is neither surplus nor scarcity of electricity energy.

Figure 46, Colum I demonstrates how much energy has to be transferred by each company. According to Figure 46;

Company A receives 40MWh energy from system.

Company B receives 20MWh energy from system.

Company C transmits 60MWh energy from system.

Company D neither transmits nor receives energy from system.

According to the results.xls in Figure 46, Column H, Zone 1 has market price, NPTF, 47.495TL/MWh, as well as Zone 2 has the same market price, NPTF, 47.495TL/MWh.

Total payments and receivables are as follows:

Company A will pay:

$$SAT_{t,p,u,r} = SAF_{t,p,u,r} \times SAM_{t,p,u,r}$$

$$SAT = 47.495 \times 40 = 1899.8 \text{ TL}$$

Company B will pay:

$$SAT_{t,p,u,r} = SAF_{t,p,u,r} \times SAM_{t,p,u,r}$$

$$SAT = 47.495 \times 20 = 949.9 \text{ TL}$$

Company C will receive:

$$SST_{t,p,u,r} = SSF_{t,p,u,r} \times SSM_{t,p,u,r}$$

$$SST = 47.495 \times 60 = 2849.7 \text{ TL}$$

Company D will neither receive nor pay for energy.

As day ahead market aims, according to the results, system is in supply and demand balance. Since Equation 6-1 claims:

$$\sum SAM = \sum SSM \text{ (Equation 6-1)}$$

For this example:

$$40\text{MWh} + 20\text{MWh} = 60\text{MWh} + 0\text{MWh}$$

Equation (1) is hold.

$$GÖPG_s = \sum_{t=1}^n \left(\sum_{p=1}^m SAT_{t,p,s} - \sum_{p=1}^m SST_{t,p,s} \right) \text{ (Equation 6-3)}$$

For this example:

$$\text{Total paid} = \sum SAT = 1899.8 \text{ TL} + 949.9 \text{ TL} = 2849.7 \text{ TL}$$

$$\text{Total received} = \sum SST = 2849.7 \text{ TL}$$

$$\text{Hence, GÖPG} = \sum SAT - \sum SST = 0 \text{ TL}$$

Resultant zonal prices are calculated as follows in Figure 51.

```

NPTF1_zone1 =
47.4950

NPTF1_zone2
NPTF1_zone2 =
47.4950

```

Figure 51 Zonal market price results generated by developed software

Since resultant zonal market prices, NPTF1_zone1 and NPTF1_zone2 are equal to each other, GÖPG becomes 0. The aim of market is to make the regional price difference in minimum level. This will affect to the end users too. The less difference in prices among region, all people will be affected more equally in whole system. So if transmission limit is 20 MW among regions in this example, ideal dispatching with market splitting is achieved. Market is ideal in this case; however, life is not always ideal.

As a whole result and comparison with Chapter 6.2.1 and Chapter 6.2.2 examples, without market splitting system seems to be in balance but in reality, since transmission congestions are not taken into consideration, actual balancing in the system do not occur, although it seems in balance. Therefore, in some regions, scarcity of electricity can occur; in some regions, surplus of energy can occur.

On the other hand, with market splitting, system is in balance but system emerge zonal prices. Transmission capacities are taken into consideration while balancing supply and demand in day ahead market. Hence, system is in balance as a whole system in physical manner. Neither surplus nor scarcity of electricity occurs. Whole grid system becomes more reliable. Since market splitting emerge different zonal prices, an amount of surplus of money also emerge. This money is used for infrastructure between zones. In ideal case, system is desired to have only 1 price, KPTF. However, in reality transmission capacities of grids limits transmission of energy. Thus, main aim is to make the difference of zonal prices at minimum level. This is acquired by improving the capacity of grids. If transmission capacity between regions is 20 MW, there would be no zonal prices, all zones would have the same price and system would be in balance both physically and economically, however, reality is not this always, so market splitting has to be applied.

CHAPTER 7

SIMULATION WITH REAL MARKET DATA

Chapter 7 includes MATLAB simulations of real market data. Simulations are performed on developed software for this thesis. All market bids are taken from “Market Financial Settlement Center”, abbreviated as MFSC which is the market operator of Turkish Day Ahead Electricity Market.

Market data is given in Appendix C.

7.1 Example 1 with current situation

Chapter 7.1 simulation is based on submitted bids for the time interval of 08:00 and 09:00 as depicted in Table C1.

Developed MATLAB software generates the supply demand curve as in Figure 52.

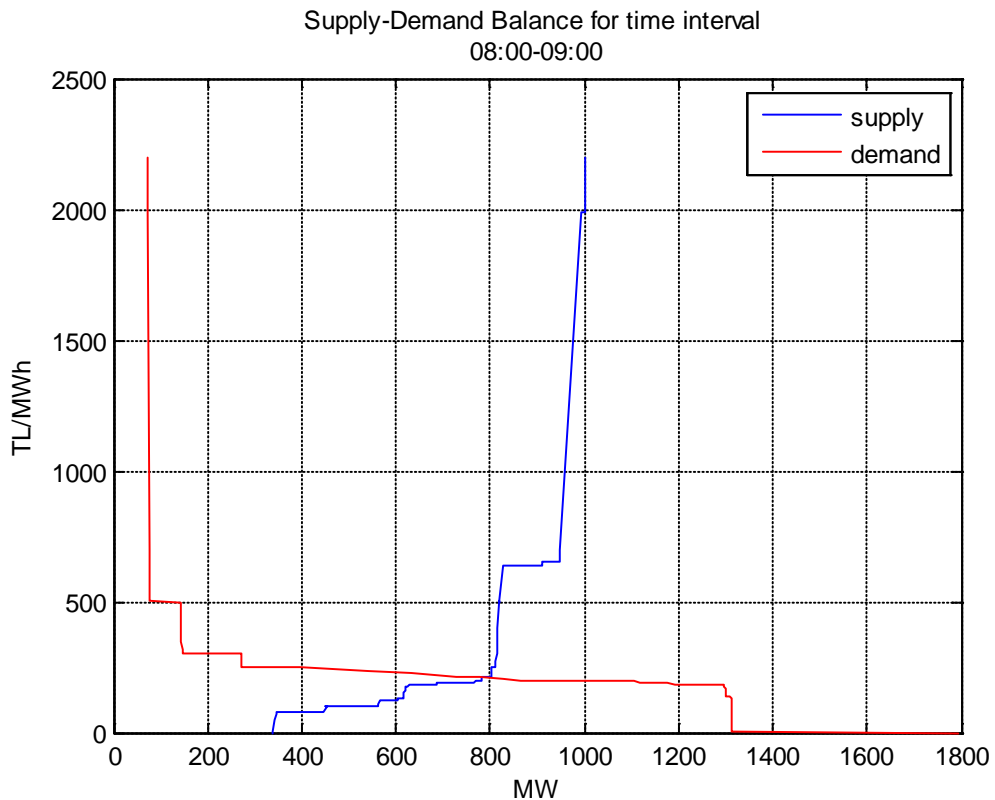

Figure 52 Supply Demand Curve for time interval 08:00-09:00

TIME INTERVAL	KPTF(TL/MWh)	COMPANY NAME	MWh	TL
08:00-09:00	209,5911645	A1	1,001047956	-209,8108068
08:00-09:00	209,5911645	B1	1,001047956	-209,8108068
08:00-09:00	209,5911645	C1	-1,211047956	253,8249514
08:00-09:00	209,5911645	D1	-2,03	425,470064
08:00-09:00	209,5911645	E1	-8,500104796	1781,546863
08:00-09:00	209,5911645	F1	-0,800104796	167,6948959
08:00-09:00	209,5911645	G1	-0,800104796	167,6948959
08:00-09:00	209,5911645	H1	0,100104796	-20,98108068
08:00-09:00	209,5911645	I1	1,001047956	-209,8108068
08:00-09:00	209,5911645	J1	10,3	-2158,788995
08:00-09:00	209,5911645	K1	19,9	-4170,864174
08:00-09:00	209,5911645	L1	0,099522448	-20,85902573
08:00-09:00	209,5911645	M1	340,9260943	-71455,09713
08:00-09:00	209,5911645	N1	0,7	-146,7138152
08:00-09:00	209,5911645	O1	1,008919152	-211,4605401
08:00-09:00	209,5911645	P1	-19,30012531	4045,13574
08:00-09:00	209,5911645	R1	-406,5	85198,80838
08:00-09:00	209,5911645	S1	0,8	-167,6729316
08:00-09:00	209,5911645	T1	-4,7	985,0784733
08:00-09:00	209,5911645	U1	1,5	-314,3867468
08:00-09:00	209,5911645	V1	1,001047956	-209,8108068
08:00-09:00	209,5911645	Y1	-55,16589268	11562,28369
08:00-09:00	209,5911645	Z1	-4,500104796	943,1822046
08:00-09:00	209,5911645	A2	10,0998952	-2116,848798
08:00-09:00	209,5911645	B2	0	0
08:00-09:00	209,5911645	C2	-3,507992637	735,244262
08:00-09:00	209,5911645	D2	-30	6287,734936
08:00-09:00	209,5911645	E2	-13,6001048	2850,461802
08:00-09:00	209,5911645	F2	0,000104796	-0,021964228
08:00-09:00	209,5911645	G2	-18,30001089	3835,520594
08:00-09:00	209,5911645	H2	0,800104796	-167,6948959
08:00-09:00	209,5911645	I2	1,200104796	-251,5313617
08:00-09:00	209,5911645	J2	1,000104796	-209,6131288
08:00-09:00	209,5911645	K2	-0,50001048	104,7977787
08:00-09:00	209,5911645	L2	1,00066993	-209,7315759
08:00-09:00	209,5911645	M2	-28,40001048	5952,391269
08:00-09:00	209,5911645	N2	-1,90001048	398,225409
08:00-09:00	209,5911645	O2	2,80008952	-586,8740234
08:00-09:00	209,5911645	P2	9,20008952	-1928,257476

Figure 53 Market results for time interval 08:00-09:00

08:00-09:00	209,5911645	R2	-0,20001048	41,92042933
08:00-09:00	209,5911645	S2	1,20008952	-251,5281601
08:00-09:00	209,5911645	T2	0,000164909	-0,034563448
08:00-09:00	209,5911645	U2	-0,10001048	20,96131288
08:00-09:00	209,5911645	V2	-2,200110643	461,1237519
08:00-09:00	209,5911645	Y2	0,000672001	-0,140845537
08:00-09:00	209,5911645	Z2	0,000672001	-0,140845537
08:00-09:00	209,5911645	A3	0,40008952	-83,85522851
08:00-09:00	209,5911645	B3	-3,50001048	733,5712723
08:00-09:00	209,5911645	C3	0,000104796	-0,021964228
08:00-09:00	209,5911645	D3	39,92412126	-8367,743069
08:00-09:00	209,5911645	E3	-11,60001048	2431,259705
08:00-09:00	209,5911645	F3	-81,60001048	17102,64122
08:00-09:00	209,5911645	G3	1,40008952	-293,446393
08:00-09:00	209,5911645	H3	0,000994677	-0,208475532
08:00-09:00	209,5911645	I3	-3,30001048	691,6530394
08:00-09:00	209,5911645	J3	0,000698637	-0,146428188
08:00-09:00	209,5911645	K3	-0,90001048	188,6342445
08:00-09:00	209,5911645	L3	3,10008952	-649,7513727
08:00-09:00	209,5911645	M3	-0,60001048	125,7568951
08:00-09:00	209,5911645	N3	5,337262111	-1118,642981
08:00-09:00	209,5911645	O3	-0,60001048	125,7568951
08:00-09:00	209,5911645	P3	-0,200003221	41,91890803
08:00-09:00	209,5911645	R3	0,700094233	-146,7335655
08:00-09:00	209,5911645	S3	0,000895204	-0,187626936
08:00-09:00	209,5911645	T3	250,0008083	-52397,96055
08:00-09:00	209,5911645	U3	0,000895204	-0,187626936
08:00-09:00	209,5911645	V3	0,805683976	-168,8642428
08:00-09:00	209,5911645	Y3	0,200002484	-41,91875353
08:00-09:00	209,5911645	Z3	0,000895204	-0,187626936
08:00-09:00	209,5911645	A4	-48,50013782	10165,20037
08:00-09:00	209,5911645	B4	0,100049548	-20,9695012
08:00-09:00	209,5911645	C4	10,0008952	-2096,099272
08:00-09:00	209,5911645	D4	1,200008952	-251,5112737
08:00-09:00	209,5911645	E4	55,70005808	-11674,24004
08:00-09:00	209,5911645	F4	0,000994688	-0,208477848
08:00-09:00	209,5911645	G4	-10,30001048	2158,791191
08:00-09:00	209,5911645	H4	-3,800000532	796,4465368
08:00-09:00	209,5911645	I4	1,04796E-05	-0,002196423
08:00-09:00	209,5911645	J4	3,500000195	-733,5691167
08:00-09:00	209,5911645	K4	-0,70001048	146,7160116

Figure 54 Market results for time interval 08:00-09:00 (continued)

08:00-09:00	209,5911645	L4	-0,400108184	83,85914026
08:00-09:00	209,5911645	M4	-1,000104796	209,6131288
08:00-09:00	209,5911645	N4	1,04796E-05	-0,002196423
08:00-09:00	209,5911645	O4	-0,40001048	83,83866224
08:00-09:00	209,5911645	P4	-0,40001048	83,83866224
08:00-09:00	209,5911645	R4	3,500063588	-733,5824034
08:00-09:00	209,5911645	S4	-3,00001048	628,77569
08:00-09:00	209,5911645	T4	-1,50001048	314,3889432
08:00-09:00	209,5911645	U4	-3,000104796	628,7954578
08:00-09:00	209,5911645	V4	-5,000058175	1047,968016

Figure 55 Market results for time interval 08:00-09:00 (continued)

In Figure 53 it is observed that, total energy traded is 0. Similarly, total paid and total received price is 0. This confirms that system is in balance both economically and physically.

Therefore, according to the developed software, day ahead market clearing price (mcp1) In TL/MWh and the quantity of energy (qty) in MW is given as in Figure 54.

$$\begin{aligned} \text{mcp1} &= \\ &209.5912 \\ \\ \text{qty} &= \\ &782.5164 \end{aligned}$$

Figure 56 Market clearing price and quantity of energy to be traded for time interval 08:00-09:00

Figure 54 shows that developed software produce the day ahead market price of electricity as 209.59 TL/MWh. However, the real market price is announced as 200 TL/MWh by MFSC [23]. Real life results and simulation results have 4.5% difference. This difference emerges from the offsets added to the bids by developed software.

7.2 Example 1 with proposed model

Example simulation in Chapter 7.1 is simulated via proposed model in this section. Market splitting is applied as if there are 2 regions in Turkey. Bids of companies are as the same as in Chapter 7.1. Transmission capacity among areas is given as 50 MW. Supply demand curve of Zone 1 is depicted in Figure 55. Moreover, supply demand curve of Zone 2 is depicted in Figure 56.

Developed Matlab software generates an output in xls format as shown in Figure 57.

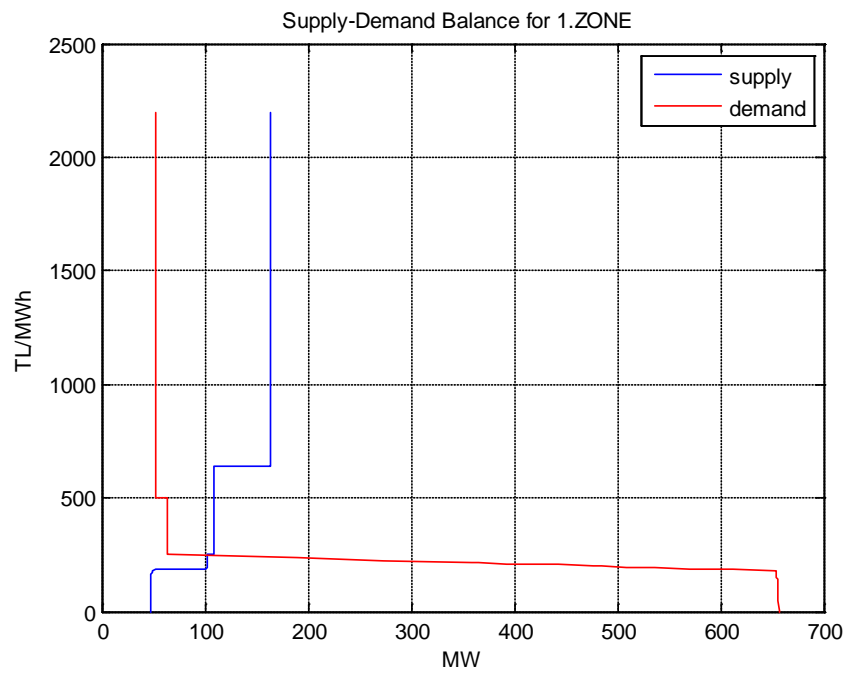

Figure 57 Supply demand balance for Zone 1 for time interval 08:00-09:00

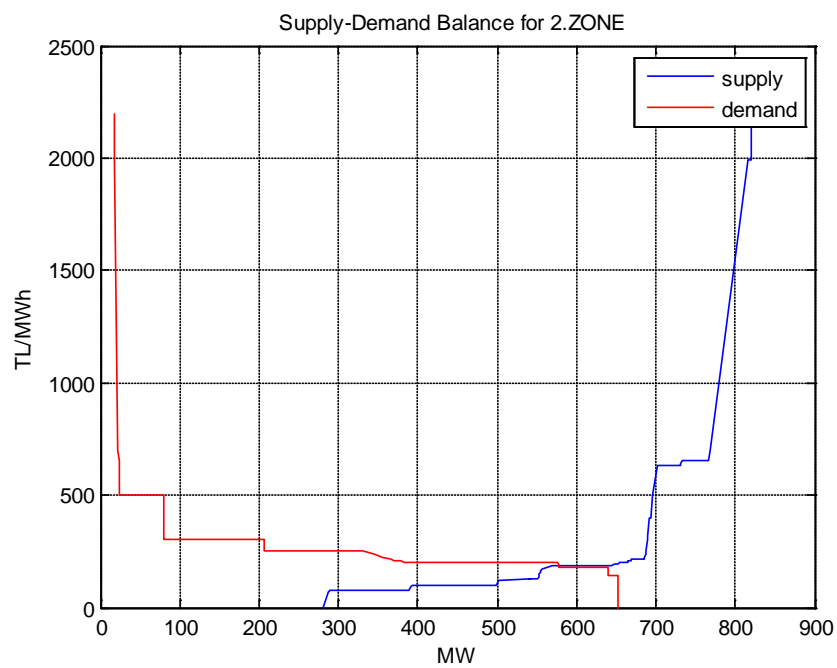

Figure 58 Supply demand balance for Zone 2 for time interval 08:00-09:00

TIME INTERVAL	KPTF	COMPANY NAME	MWh	TL	REGION	NPTF	MWh	TL
08:00-09:00	210,4877223	A1	1,001052439	-210,7092477	1.ZONE	239,4801327	1,001197401	-239,7668864
08:00-09:00	210,4877223	B1	1,001052439	-210,7092477	1.ZONE	239,4801327	1,001197401	-239,7668864
08:00-09:00	210,4877223	C1	-1,211052439	254,9116694	2.ZONE	189,861054	-1,210949305	229,9121114
08:00-09:00	210,4877223	D1	-2,03	427,2900762	1.ZONE	239,4801327	-2,03	486,1446694
08:00-09:00	210,4877223	E1	-8,500105244	1789,167792	1.ZONE	239,4801327	-8,50011974	2035,609803
08:00-09:00	210,4877223	F1	-0,800105244	168,4123304	1.ZONE	239,4801327	-0,80011974	191,6127815
08:00-09:00	210,4877223	G1	-0,800105244	168,4123304	1.ZONE	239,4801327	-0,80011974	191,6127815
08:00-09:00	210,4877223	H1	0,100105244	-21,07092477	2.ZONE	189,861054	0,100094931	-19,00412901
08:00-09:00	210,4877223	I1	1,001052439	-210,7092477	1.ZONE	239,4801327	1,001197401	-239,7668864
08:00-09:00	210,4877223	J1	10,3	-2168,023539	1.ZONE	239,4801327	10,3	-2466,645367
08:00-09:00	210,4877223	K1	19,9	-4188,705673	1.ZONE	239,4801327	19,9	-4765,654641
08:00-09:00	210,4877223	L1	0,099472611	-20,93776339	2.ZONE	189,861054	4,290506947	-814,6001711
08:00-09:00	210,4877223	M1	333,3619088	-70168,58888	1.ZONE	239,4801327	88,75527404	-21255,12481
08:00-09:00	210,4877223	N1	0,7	-147,3414056	2.ZONE	189,861054	0,7	-132,9027378
08:00-09:00	210,4877223	O1	1,008957306	-212,3731251	2.ZONE	189,861054	1,008079538	-191,3950435
08:00-09:00	210,4877223	P1	-19,30013026	4062,440458	2.ZONE	189,861054	-19,3000165	3664,321474
08:00-09:00	210,4877223	R1	-406,5	85563,2591	2.ZONE	189,861054	-406,5	77178,51844
08:00-09:00	210,4877223	S1	0,8	-168,3901778	1.ZONE	239,4801327	0,8	-191,5841062
08:00-09:00	210,4877223	T1	-4,7	989,2922947	2.ZONE	189,861054	0	0
08:00-09:00	210,4877223	U1	1,5	-315,7315834	1.ZONE	239,4801327	1,5	-359,2201991
08:00-09:00	210,4877223	V1	1,001052439	-210,7092477	1.ZONE	239,4801327	1,001197401	-239,7668864
08:00-09:00	210,4877223	Y1	-55,19835874	11618,5768	2.ZONE	189,861054	-38,57631746	7324,14029
08:00-09:00	210,4877223	Z1	-4,500105244	947,2169028	1.ZONE	239,4801327	-4,50011974	1077,689273
08:00-09:00	210,4877223	A2	10,09989476	-2125,903842	1.ZONE	239,4801327	10,09988026	-2418,720665
08:00-09:00	210,4877223	B2	0	0	2.ZONE	189,861054	187,5	-35598,94762
08:00-09:00	210,4877223	C2	-3,508739769	738,5466419	1.ZONE	239,4801327	-3,532900111	846,0593874
08:00-09:00	210,4877223	D2	-30	6314,631668	2.ZONE	189,861054	-30	5695,831619
08:00-09:00	210,4877223	E2	-13,60010524	2862,655175	2.ZONE	189,861054	-13,60009493	2582,128358
08:00-09:00	210,4877223	F2	0,000105244	-0,022152541	1.ZONE	239,4801327	0,00011974	-0,028675367
08:00-09:00	210,4877223	G2	-18,30001139	3851,927715	2.ZONE	189,861054	-1,928755678	366,1955859
08:00-09:00	210,4877223	H2	0,800105244	-168,4123304	2.ZONE	189,861054	0,800094931	-151,9068668
08:00-09:00	210,4877223	I2	1,200105244	-252,6074193	1.ZONE	239,4801327	1,20011974	-287,4048346
08:00-09:00	210,4877223	J2	1,000105244	-210,5098748	1.ZONE	239,4801327	1,00011974	-239,5088081
08:00-09:00	210,4877223	K2	-0,500010524	105,2460764	1.ZONE	239,4801327	-0,500011974	119,7429339
08:00-09:00	210,4877223	L2	1,000668518	-210,6284371	2.ZONE	189,861054	1,000701002	-189,9941468
08:00-09:00	210,4877223	M2	-28,40001052	5977,853528	1.ZONE	239,4801327	-28,40001197	6801,238637
08:00-09:00	210,4877223	N2	-1,900010524	399,9288876	1.ZONE	239,4801327	-1,900011974	455,0151197
08:00-09:00	210,4877223	O2	2,800089476	-589,3844559	1.ZONE	239,4801327	2,800088026	-670,5654521
08:00-09:00	210,4877223	P2	9,200089476	-1936,505878	1.ZONE	239,4801327	9,200088026	-2203,238301
08:00-09:00	210,4877223	R2	-0,200010524	42,09975971	1.ZONE	239,4801327	-0,200011974	47,89889408
08:00-09:00	210,4877223	S2	1,200089476	-252,6041002	1.ZONE	239,4801327	1,200088026	-287,3972397
08:00-09:00	210,4877223	T2	0,000161337	-0,033959388	1.ZONE	239,4801327	4,58199E-05	-0,010972945
08:00-09:00	210,4877223	U2	-0,100010524	21,05098748	1.ZONE	239,4801327	-0,100011974	23,95088081
08:00-09:00	210,4877223	V2	-2,200110919	463,0963361	1.ZONE	239,4801327	-2,20011984	526,8849913
08:00-09:00	210,4877223	Y2	0,000670598	-0,141152697	1.ZONE	239,4801327	0,000625227	-0,149729375
08:00-09:00	210,4877223	Z2	0,000670598	-0,141152697	1.ZONE	239,4801327	0,000625227	-0,149729375
08:00-09:00	210,4877223	A3	0,400089476	-84,21392243	2.ZONE	189,861054	0,400090507	-75,96160533
08:00-09:00	210,4877223	B3	-3,500010524	736,7092432	2.ZONE	189,861054	-3,500009493	664,5154912
08:00-09:00	210,4877223	C3	0,000105244	-0,022152541	2.ZONE	189,861054	9,49305E-05	-0,01802361
08:00-09:00	210,4877223	D3	39,03834015	-8217,0913	2.ZONE	189,861054	49,40000507	-9379,137028
08:00-09:00	210,4877223	E3	-11,60001052	2441,659794	2.ZONE	189,861054	-11,60000949	2202,390028
08:00-09:00	210,4877223	F3	-81,60001052	17175,80035	2.ZONE	189,861054	-81,60000949	15492,66381
08:00-09:00	210,4877223	G3	1,400089476	-294,7016447	2.ZONE	189,861054	1,400090507	-265,8226593
08:00-09:00	210,4877223	H3	0,000994179	-0,209262476	2.ZONE	189,861054	0,300005069	-56,95927868
08:00-09:00	210,4877223	I3	-3,300010524	694,6116987	2.ZONE	189,861054	-3,300009493	626,5432804
08:00-09:00	210,4877223	J3	0,000701626	-0,147683604	2.ZONE	189,861054	0,00063287	-0,120157399
08:00-09:00	210,4877223	K3	-0,900010524	189,4411653	2.ZONE	189,861054	-0,900009493	170,8767509
08:00-09:00	210,4877223	L3	3,100089476	-652,5307726	2.ZONE	189,861054	3,100090507	-588,586451
08:00-09:00	210,4877223	M3	-0,600010524	126,2948486	2.ZONE	189,861054	-0,600009493	113,9184347
08:00-09:00	210,4877223	N3	5,334589446	-1122,865582	2.ZONE	189,861054	5,396078159	-1024,505087
08:00-09:00	210,4877223	O3	-0,600010524	126,2948486	2.ZONE	189,861054	-0,600009493	113,9184347

Figure 59 Market results for time interval 08:00-09:00 with market splitting

08:00-09:00	210,4877223	P3	-0,20000327	42,09823267	2.ZONE	189,861054	-0,200002155	37,97261988
08:00-09:00	210,4877223	R3	0,700094185	-147,3612304	2.ZONE	189,861054	0,700095271	-132,920826
08:00-09:00	210,4877223	S3	0,000894756	-0,188335182	2.ZONE	189,861054	0,000905069	-0,171837444
08:00-09:00	210,4877223	T3	250,0007904	-52622,09694	2.ZONE	189,861054	250,0022069	-47465,6825
08:00-09:00	210,4877223	U3	0,000894756	-0,188335182	2.ZONE	189,861054	0,000905069	-0,171837444
08:00-09:00	210,4877223	V3	0,805280525	-169,5016635	2.ZONE	189,861054	0,814562526	-154,6536997
08:00-09:00	210,4877223	Y3	0,200002067	-42,0979795	2.ZONE	189,861054	0,200011664	-37,97442529
08:00-09:00	210,4877223	Z3	0,000894756	-0,188335182	1.ZONE	239,4801327	0,00088026	-0,210804766
08:00-09:00	210,4877223	A4	-48,5001392	10208,68383	1.ZONE	239,4801327	-48,50018381	11614,83046
08:00-09:00	210,4877223	B4	0,100039695	-21,05712761	2.ZONE	189,861054	0,200076032	-37,9866464
08:00-09:00	210,4877223	C4	10,00089476	-2105,065558	2.ZONE	189,861054	10,00090507	-1898,782377
08:00-09:00	210,4877223	D4	1,200008948	-252,5871501	1.ZONE	239,4801327	1,200008803	-287,3782673
08:00-09:00	210,4877223	E4	55,7000579	-11724,17832	2.ZONE	189,861054	55,70006203	-10575,27248
08:00-09:00	210,4877223	F4	0,00099419	-0,209264801	1.ZONE	239,4801327	0,000978083	-0,234231421
08:00-09:00	210,4877223	G4	-10,30001052	2168,025755	2.ZONE	189,861054	-10,30000949	1955,570658
08:00-09:00	210,4877223	H4	-3,800000582	799,8534672	2.ZONE	189,861054	-2,8000922	531,6284563
08:00-09:00	210,4877223	I4	1,05244E-05	-0,002215254	1.ZONE	239,4801327	1,1974E-05	-0,002867537
08:00-09:00	210,4877223	J4	0,085944107	-18,09017922	2.ZONE	189,861054	3,50000959	-664,5155096

**Figure 60 Market results for time interval 08:00-09:00 with market splitting
(continued)**

If there is no connection among areas, market results would be as follows in Figure 57;

mcp1_zone1 =

245.4059

qty_zone1 =

101.9687

mcp1_zone2 =

186.8626

qty_zone2 =

576.5267

Figure 61 Market clearing price and quantity of energy to be traded of each zone before power exchange among zones

It is observed in Figure 57 that market price in zone 1 is 245.4059 TL/MWh; zone 2 has a market clearing price of 186.8626 TL/MWh. Since zone 1 has higher market price, zone 2 has to supply energy to zone 1 within limit of transmission capacity among zones.

After power exchange among areas, market prices in each zones becomes as in Figure 59.

```

NPTF_zone1 =
    239.4801

qty_zone1 =
    151.9637

NPTF_zone2 =
    189.8611

qty_zone2 =
    626.5163

```

Figure 62 Market clearing price and quantity of energy to be traded of each zone after power exchange among zones

7.3 Example 2 with current situation

Chapter 7.3 simulation is based on simulation between 11:00 and 12:00 in Table C2. Developed MATLAB software generates the supply demand curve as in Figure 60.

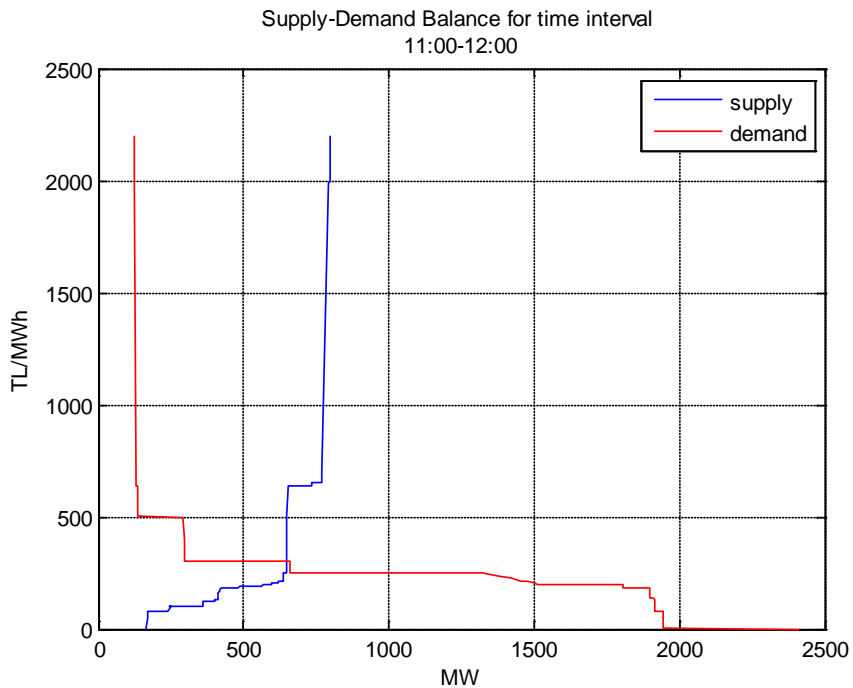

Figure 63 Supply Demand Curve for time interval 11:00-12:00

TIME INTERVAL	KPTF(TL/MWh)	COMPANY NAME	MWh	TL
11:00-12:00	300,0003018	A1	0,00085	-0,255000211
11:00-12:00	300,0003018	B1	0,00085	-0,255000211
11:00-12:00	300,0003018	C1	2,500085	-750,0262544
11:00-12:00	300,0003018	D1	25,200085	-7560,033105
11:00-12:00	300,0003018	E1	-8,50015	2550,047565
11:00-12:00	300,0003018	F1	-1,500015	450,0049527
11:00-12:00	300,0003018	G1	0,200085	-60,02556037
11:00-12:00	300,0003018	H1	0,00085	-0,255000211
11:00-12:00	300,0003018	I1	0,00085	-0,255000211
11:00-12:00	300,0003018	J1	19,10004	-5730,017764
11:00-12:00	300,0003018	K1	34,00085042	-10200,26539
11:00-12:00	300,0003018	L1	0,094496926	-28,34910631
11:00-12:00	300,0003018	M1	0,000971434	-0,291430478
11:00-12:00	300,0003018	N1	0,700085	-210,0257113
11:00-12:00	300,0003018	O1	1,600096317	-480,0293779
11:00-12:00	300,0003018	P1	-19,30062395	5790,193009
11:00-12:00	300,0003018	R1	-226,5002086	67950,13093
11:00-12:00	300,0003018	S1	1,600085	-480,0259828
11:00-12:00	300,0003018	T1	-4,700051712	1410,016932
11:00-12:00	300,0003018	U1	2,600085	-780,0262846
11:00-12:00	300,0003018	V1	0,100085	-30,0255302
11:00-12:00	300,0003018	Y1	-96,32393915	28897,21081
11:00-12:00	300,0003018	Z1	-1,00015	300,0453019
11:00-12:00	300,0003018	A2	-0,800015	240,0047414
11:00-12:00	300,0003018	B2	0,000957746	-0,287324182
11:00-12:00	300,0003018	C2	-3,583333585	1075,001157
11:00-12:00	300,0003018	D2	-30,000062	9000,027652
11:00-12:00	300,0003018	E2	-13,70015	4110,049134
11:00-12:00	300,0003018	F2	-0,600015	180,0046811
11:00-12:00	300,0003018	G2	-18,30006084	5490,023775
11:00-12:00	300,0003018	H2	1,900085	-570,0260734
11:00-12:00	300,0003018	I2	1,20015	-360,0453622
11:00-12:00	300,0003018	J2	1,700085	-510,026013
11:00-12:00	300,0003018	K2	-0,800015	240,0047414
11:00-12:00	300,0003018	L2	1,000527551	-300,1585673
11:00-12:00	300,0003018	M2	-23,300015	6990,011531
11:00-12:00	300,0003018	N2	-1,600015	480,0049828
11:00-12:00	300,0003018	O2	3,00085	-900,2559055
11:00-12:00	300,0003018	P2	12,600085	-3780,029302
11:00-12:00	300,0003018	R2	-0,200015	60,00456036
11:00-12:00	300,0003018	S2	2,800085	-840,026345
11:00-12:00	300,0003018	T2	-6,800002802	2040,002893
11:00-12:00	300,0003018	U2	-0,100015	30,00453019
11:00-12:00	300,0003018	V2	-2,200138462	660,0422024
11:00-12:00	300,0003018	Y2	0,000530516	-0,159154948
11:00-12:00	300,0003018	Z2	0,000530516	-0,159154948
11:00-12:00	300,0003018	A3	0,400085	-120,0256207
11:00-12:00	300,0003018	B3	-3,500015	1050,005556

Figure 64 Market results for time interval 11:00-12:00

11:00-12:00	300,0003018	C3	0,00015	-0,045000091
11:00-12:00	300,0003018	D3	0,000971428	-0,291428813
11:00-12:00	300,0003018	E3	-5,700015	1710,00622
11:00-12:00	300,0003018	F3	-72,800015	21840,02647
11:00-12:00	300,0003018	G3	3,500085	-1050,026556
11:00-12:00	300,0003018	H3	0,00094445	-0,283335142
11:00-12:00	300,0003018	I3	1,700085	-510,026013
11:00-12:00	300,0003018	J3	1,999999645	-600,000497
11:00-12:00	300,0003018	K3	-0,300015	90,00459054
11:00-12:00	300,0003018	L3	5,015085015	-1504,527018
11:00-12:00	300,0003018	M3	-0,600015	180,0046811
11:00-12:00	300,0003018	N3	9,674795031	-2902,441429
11:00-12:00	300,0003018	O3	-0,600015	180,0046811
11:00-12:00	300,0003018	P3	-0,200008108	60,00249279
11:00-12:00	300,0003018	R3	-1,300110526	390,0335501
11:00-12:00	300,0003018	S3	0,00085	-0,255000211
11:00-12:00	300,0003018	T3	349,1366333	-104741,0953
11:00-12:00	300,0003018	U3	-0,300015	90,00459054
11:00-12:00	300,0003018	V3	1,784999683	-535,5004436
11:00-12:00	300,0003018	Y3	-17,00004765	5100,019425
11:00-12:00	300,0003018	Z3	0,00085	-0,255000211
11:00-12:00	300,0003018	A4	-48,50030286	14550,10549
11:00-12:00	300,0003018	B4	0,000952381	-0,285714522
11:00-12:00	300,0003018	C4	10,00085	-3000,258018
11:00-12:00	300,0003018	D4	2,5000085	-750,0033044
11:00-12:00	300,0003018	E4	140,00004	-42000,05425
11:00-12:00	300,0003018	F4	0,00094446	-0,28333829
11:00-12:00	300,0003018	G4	-10,000015	3000,007518
11:00-12:00	300,0003018	H4	5,40018889	-1620,058297
11:00-12:00	300,0003018	I4	-1,500015	450,0049527
11:00-12:00	300,0003018	J4	-3,3000182	990,006456
11:00-12:00	300,0003018	K4	0,900085	-270,0257716
11:00-12:00	300,0003018	L4	-0,400112821	120,0339669
11:00-12:00	300,0003018	M4	-1,00015	300,0453019
11:00-12:00	300,0003018	N4	-4,00015	1200,046207
11:00-12:00	300,0003018	O4	-0,6000015	180,0006311
11:00-12:00	300,0003018	P4	-0,200015	60,00456036
11:00-12:00	300,0003018	R4	2,187524298	-656,2579496
11:00-12:00	300,0003018	S4	-5,00015	1500,046509
11:00-12:00	300,0003018	T4	-1,500015	450,0049527
11:00-12:00	300,0003018	U4	-2,00015	600,0456036
11:00-12:00	300,0003018	V4	-6,000105734	1800,033531

Figure 65 Market results for time interval 11:00-12:00 (continued)

In Figure 61, it is observed that, total energy traded is 0. Similarly, total paid and total received price is 0. This confirms that system is in balance both economically and physically.

Therefore, according to the developed software, day ahead market clearing price (mcp1) In TL/MWh and the quantity of energy (qty) in MW is given as in Figure 62.

```
mcp1 =  
300.0003  
  
qty =  
646.1105
```

Figure 66 Market clearing price and quantity of energy to be traded for time interval 11:00-12:00

However, the real market price is announced as 210 TL/MWh by MFSC [23]. Real life results and simulation results have 30% difference. This difference emerges from the block bids entered at this time interval. Developed software has low capability to handle block bids entered to the market.

7.4 Example 2 with proposed model

Example simulation in Chapter 7.3 is simulated via proposed model in this section. Market splitting is applied as if there are 2 regions in Turkey. Bids of companies are as the same as in Chapter 7.1. Transmission capacity among areas is given as 50 MW. Supply demand curve of Zone 1 is depicted in Figure 63. Moreover, supply demand curve of Zone 2 is depicted in Figure 64.

Developed Matlab software generates an output in xls format as shown in Figure 65.

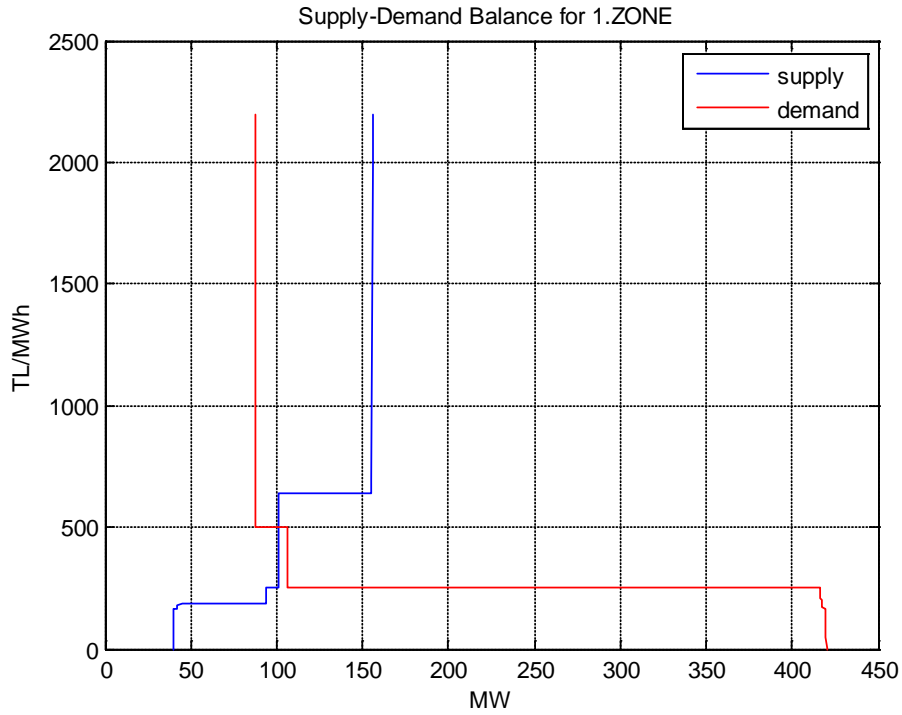

Figure 67 Supply demand balance for Zone 1 for time interval 08:00-09:00

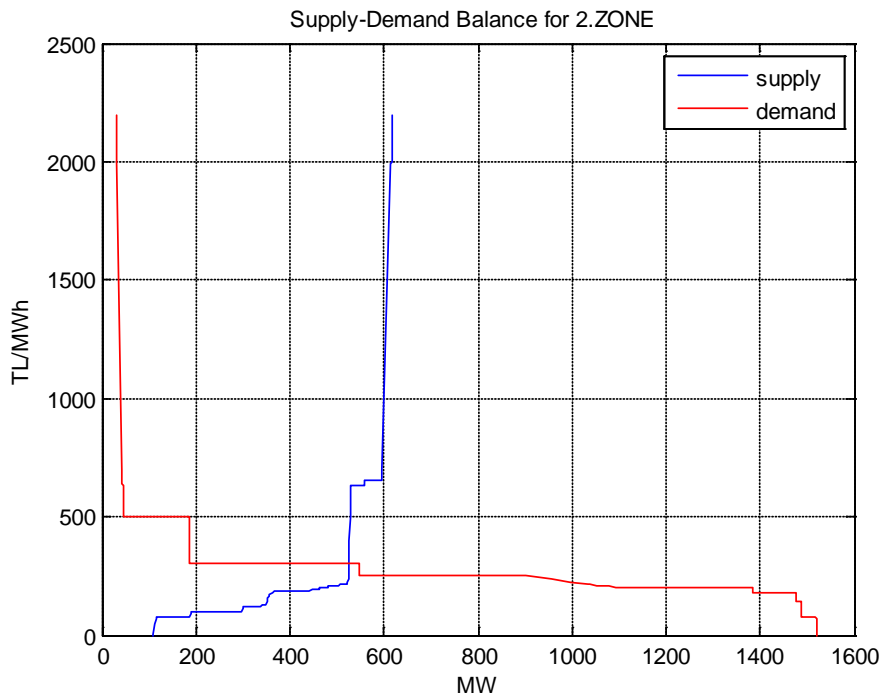

Figure 68 Supply demand balance for Zone 2 for time interval 11:00-12:00

TIME INTERVAL	KPTF	COMPANY NAME	MWh	TL	REGION	NPTF	MWh	TL
11:00-12:00	300,0003018	A1	0,00085	-0,255000211	1.ZONE	250,0087893	0,000874996	-0,218756592
11:00-12:00	300,0003018	B1	0,00085	-0,255000211	1.ZONE	250,0087893	0,000874996	-0,218756592
11:00-12:00	300,0003018	C1	2,500085	-750,0262544	2.ZONE	250,0087893	2,5000875	-625,0438488
11:00-12:00	300,0003018	D1	25,200085	-7560,033105	1.ZONE	250,0087893	25,2000875	-6300,243365
11:00-12:00	300,0003018	E1	-8,50015	2550,047565	1.ZONE	250,0087893	-8,500125004	2125,105961
11:00-12:00	300,0003018	F1	-1,500015	450,0049527	1.ZONE	250,0087893	-1,5000125	375,0163091
11:00-12:00	300,0003018	G1	0,200085	-60,02556037	1.ZONE	250,0087893	0,2000875	-50,02363351
11:00-12:00	300,0003018	H1	0,00085	-0,255000211	2.ZONE	250,0087893	0,000874996	-0,218756592
11:00-12:00	300,0003018	I1	0,00085	-0,255000211	1.ZONE	250,0087893	0,000874996	-0,218756592
11:00-12:00	300,0003018	J1	19,10004	-5730,017764	1.ZONE	250,0087893	19,10005	-4775,180375
11:00-12:00	300,0003018	K1	34,00085042	-10200,26539	1.ZONE	250,0087893	34,00087543	-8500,5177
11:00-12:00	300,0003018	L1	0,094496926	-28,34910631	2.ZONE	250,0087893	0,097275776	-24,31979899
11:00-12:00	300,0003018	M1	0,000971434	-0,291430478	1.ZONE	250,0087893	37,53411972	-9383,859826
11:00-12:00	300,0003018	N1	0,700085	-210,0257113	2.ZONE	250,0087893	0,7000875	-175,0280281
11:00-12:00	300,0003018	O1	1,600096317	-480,0293779	2.ZONE	250,0087893	1,600099149	-400,0388509
11:00-12:00	300,0003018	P1	-19,30062395	5790,193009	2.ZONE	250,0087893	-19,30034823	4825,256693
11:00-12:00	300,0003018	R1	-226,5002086	67950,13093	2.ZONE	250,0087893	-226,5002059	56627,04225
11:00-12:00	300,0003018	S1	1,600085	-480,0259828	1.ZONE	250,0087893	1,6000875	-400,0359385
11:00-12:00	300,0003018	T1	-4,700051712	1410,016932	2.ZONE	250,0087893	-4,700027326	1175,048141
11:00-12:00	300,0003018	U1	2,600085	-780,0262846	1.ZONE	250,0087893	2,6000875	-650,0447277
11:00-12:00	300,0003018	V1	0,100085	-30,0255302	1.ZONE	250,0087893	0,1000875	-25,02275458
11:00-12:00	300,0003018	Y1	-96,32393915	28897,21081	2.ZONE	250,0087893	-95,62770251	23907,76612
11:00-12:00	300,0003018	Z1	-1,00015	300,0453019	1.ZONE	250,0087893	-1,000125004	250,0400415
11:00-12:00	300,0003018	A2	-0,800015	240,0047414	1.ZONE	250,0087893	-0,8000125	200,0101566
11:00-12:00	300,0003018	B2	0,000957746	-0,287324182	2.ZONE	250,0087893	0,000985911	-0,246486301
11:00-12:00	300,0003018	C2	-3,583333585	1075,001157	1.ZONE	250,0087893	-3,541673991	885,4496264
11:00-12:00	300,0003018	D2	-30,000062	9000,027652	2.ZONE	250,0087893	-30,00003441	7500,272281
11:00-12:00	300,0003018	E2	-13,70015	4110,049134	2.ZONE	250,0087893	-13,700125	3425,151665
11:00-12:00	300,0003018	F2	-0,600015	180,0046811	1.ZONE	250,0087893	-0,6000125	150,0083988
11:00-12:00	300,0003018	G2	-18,30006084	5490,023775	2.ZONE	250,0087893	-18,30003322	4575,16915
11:00-12:00	300,0003018	H2	1,900085	-570,0260734	2.ZONE	250,0087893	1,9000875	-475,0385752
11:00-12:00	300,0003018	I2	1,20015	-360,0453622	1.ZONE	250,0087893	1,200125004	-300,0417993
11:00-12:00	300,0003018	J2	1,700085	-510,026013	1.ZONE	250,0087893	1,7000875	-425,0368174
11:00-12:00	300,0003018	K2	-0,800015	240,0047414	1.ZONE	250,0087893	-0,8000125	200,0101566
11:00-12:00	300,0003018	L2	1,000527551	-300,1585673	2.ZONE	250,0087893	1,000606279	-250,1603644
11:00-12:00	300,0003018	M2	-23,300015	6990,011531	1.ZONE	250,0087893	-23,3000125	5825,207915
11:00-12:00	300,0003018	N2	-1,600015	480,0049828	1.ZONE	250,0087893	-1,6000125	400,017188
11:00-12:00	300,0003018	O2	3,00085	-900,2559055	1.ZONE	250,0087893	3,000874996	-750,2451244
11:00-12:00	300,0003018	P2	12,600085	-3780,029302	1.ZONE	250,0087893	12,6000875	-3150,13262
11:00-12:00	300,0003018	R2	-0,200015	60,00456036	1.ZONE	250,0087893	-0,2000125	50,00488307
11:00-12:00	300,0003018	S2	2,800085	-840,026345	1.ZONE	250,0087893	2,8000875	-700,0464856
11:00-12:00	300,0003018	T2	-6,800002802	2040,002893	1.ZONE	250,0087893	3,86967E-06	-0,000967452
11:00-12:00	300,0003018	U2	-0,100015	30,00453019	1.ZONE	250,0087893	-0,1000125	25,00400415
11:00-12:00	300,0003018	V2	-2,200138462	660,0422024	1.ZONE	250,0087893	-2,20012308	550,0501073
11:00-12:00	300,0003018	Y2	0,000530516	-0,159154948	1.ZONE	250,0087893	0,00060875	-0,152192835
11:00-12:00	300,0003018	Z2	0,000530516	-0,159154948	1.ZONE	250,0087893	0,00060875	-0,152192835
11:00-12:00	300,0003018	A3	0,400085	-120,0256207	2.ZONE	250,0087893	0,4000875	-100,0253914
11:00-12:00	300,0003018	B3	-3,500015	1050,005556	2.ZONE	250,0087893	-3,5000125	875,0338876
11:00-12:00	300,0003018	C3	0,00015	-0,045000091	2.ZONE	250,0087893	0,000125004	-0,031252197
11:00-12:00	300,0003018	D3	0,000971428	-0,291428813	2.ZONE	250,0087893	0,000999995	-0,250007534
11:00-12:00	300,0003018	E3	-5,700015	1710,00622	2.ZONE	250,0087893	-5,7000125	1425,053224
11:00-12:00	300,0003018	F3	-72,800015	21840,02647	2.ZONE	250,0087893	-72,8000125	18200,64298
11:00-12:00	300,0003018	G3	3,500085	-1050,026556	2.ZONE	250,0087893	3,5000875	-875,052638
11:00-12:00	300,0003018	H3	0,00094445	-0,283335142	2.ZONE	250,0087893	0,000972223	-0,24306423
11:00-12:00	300,0003018	I3	1,700085	-510,026013	2.ZONE	250,0087893	1,7000875	-425,0368174
11:00-12:00	300,0003018	J3	1,999999645	-600,000497	2.ZONE	250,0087893	2,000166637	-500,0592393
11:00-12:00	300,0003018	K3	-0,300015	90,00459054	2.ZONE	250,0087893	-0,3000125	75,005762
11:00-12:00	300,0003018	L3	5,015085015	-1504,527018	2.ZONE	250,0087893	5,012587939	-1253,191042
11:00-12:00	300,0003018	M3	-0,600015	180,0046811	2.ZONE	250,0087893	-0,6000125	150,0083988
11:00-12:00	300,0003018	N3	9,674795031	-2902,441429	2.ZONE	250,0087893	9,959299573	-2489,912428
11:00-12:00	300,0003018	O3	-0,600015	180,0046811	2.ZONE	250,0087893	-0,6000125	150,0083988

Figure 69 Market results for time interval 11:00-12:00 with market splitting

11:00-12:00	300,0003018	P3	-0,200008108	60,00249279		2.ZONE	250,0087893	-0,200005406	50,00310937
11:00-12:00	300,0003018	R3	-1,300110526	390,0335501		2.ZONE	250,0087893	-1,300107895	325,0384007
11:00-12:00	300,0003018	S3	0,00085	-0,255000211		2.ZONE	250,0087893	0,000874996	-0,218756592
11:00-12:00	300,0003018	T3	349,1366333	-104741,0953		2.ZONE	250,0087893	402,7394145	-100688,3934
11:00-12:00	300,0003018	U3	-0,300015	90,00459054		2.ZONE	250,0087893	-0,3000125	75,005762
11:00-12:00	300,0003018	V3	1,784999683	-535,5004436		2.ZONE	250,0087893	1,837490771	-459,388843
11:00-12:00	300,0003018	Y3	-17,00004765	5100,019425		2.ZONE	250,0087893	-17,00001965	4250,154329
11:00-12:00	300,0003018	Z3	0,00085	-0,255000211		1.ZONE	250,0087893	0,000874996	-0,218756592
11:00-12:00	300,0003018	A4	-48,50030286	14550,10549		1.ZONE	250,0087893	-48,50028789	12125,49825
11:00-12:00	300,0003018	B4	0,000952381	-0,285714522		2.ZONE	250,0087893	0,000980387	-0,245105425
11:00-12:00	300,0003018	C4	10,00085	-3000,258018		2.ZONE	250,0087893	10,000875	-2500,306649
11:00-12:00	300,0003018	D4	2,5000085	-750,0033044		1.ZONE	250,0087893	2,50000875	-625,0241607
11:00-12:00	300,0003018	E4	140,00004	-42000,05425		2.ZONE	250,0087893	140,00005	-35001,243
11:00-12:00	300,0003018	F4	0,00094446	-0,28333829		1.ZONE	250,0087893	0,000972234	-0,243066931
11:00-12:00	300,0003018	G4	-10,000015	3000,007518		2.ZONE	250,0087893	-10,0000125	2500,091018
11:00-12:00	300,0003018	H4	5,40018889	-1620,058297		2.ZONE	250,0087893	5,400194445	-1350,096075
11:00-12:00	300,0003018	I4	-1,500015	450,0049527		1.ZONE	250,0087893	-1,5000125	375,0163091
11:00-12:00	300,0003018	J4	-3,3000182	990,006456		2.ZONE	250,0087893	-3,300007977	825,0309989

**Figure 70 Market results for time interval 11:00-12:00 with market splitting
(continued)**

It is observed in Figure 63 that market price in zone 1 is 500.0029 TL/MWh. Similarly Figure 64 depicts that zone 2 has a market clearing price of 230.0006 TL/MWh. Since zone 1 has higher market price, zone 2 has to supply energy to zone 1 within limit of transmission capacity among zones.

After power exchange among areas, market prices in each zones becomes as in Figure 66.

NPTF1_zone1 =

250.0088

qty_zone1 =

144.1424

NPTF1_zone2 =

250.0088

qty_zone2 =

524.4254

Figure 71 Market clearing price and quantity of energy to be traded of each zone after power exchange among zones

This means that whole system has perfect balance with market splitting since there is no regional market clearing price differences. As a result, whole market price is decreased from

500 TL/MWh to 350 TL/MWh via market splitting. Since this interval includes block bids and handling of block bids by developed software is low; prices seem to be higher. However, as the software improved, more optimized results can be achieved. Hence, even developed software has not high success rate, prices is lowered via market splitting and proves that market splitting manages transmission congestion more that without market splitting case.

CHAPTER 8

RESULTS AND FUTURE WORK

8.1 Results

In this thesis, in Chapter 2, overview and evolution of Electricity Markets are studied. Beginning from state owned structures to private structures are studied. Hence, Chapter 2 shows how the need for Day Ahead Markets occurred. Towards the end of Chapter 2, it is depicted that modern electricity markets are based on competition in generation and wholesale and/or retail sale. Thus, Day Ahead Market has to be applied in electricity markets because electricity trading is based mostly on bilateral contracts. Since bilateral contracts give freedom to market participants to sign contracts, supply demand imbalances occur in overall system. Therefore, Day Ahead Markets provide extra chance for market participants to trade energy. As a result of Day Ahead Markets, system is balanced one day ahead of actual transfer of energy in a purely competitive area.

Chapter 3 is based on pricing of Day Ahead Markets. Cost modeling is studied in order to depict how a plant should bid in competitive market so that market participant aims to maximize its own profit. According to the costs, plants make their bid to the market. Cost modeling results with marginal cost; because marginal cost depicts the bids of a plant to the market. Hence, marginal cost concept is examined in Chapter 3.

Chapter 3 also includes Short Term Load Forecasting. Short Term Load Forecasting has to be studied in that demand of system is based on forecasting. Forecasted data is useful for supply side, demand side and system operator. Electricity has a specific property that electricity production and consumption must be the equal in any second in system. Otherwise, quality of electricity decreases because frequency of line voltage changes. From economic point of view, production company makes loss. Therefore, accurate estimations have to be done. As a load forecasting method, ANN is studied and a comprehensive example is studied. As a result, it is showed that as the variety of data imported to the ANN network is increased, the forecast achieves more accurate results. In Chapter 3.3.2 example, 2 different cases are studied. In first part, only historical temperature data is inserted to the ANN box and regression is calculated. In second part, not only historical temperature is inserted, but also historical humidity data is inserted to the ANN box. It is proved and calculated that, with temperature and humidity data, regression increased which means accuracy of forecasting is increased.

In Chapter 4 and Chapter 5, Day Ahead Markets and Turkish Day Ahead Market Structure are studied in detail. Structure of Day Ahead Markets, Sides of Day Ahead Markets, Mechanism of Day Ahead Market, Hardware and Software Infrastructures of Day Ahead

Markets, Supply-Demand Balance in Day Ahead Markets are studied. Moreover, Models of Day Ahead Markets in the World section includes comprehensive analyses of day ahead market models exist. Hence, it is shown that, the current Turkish day ahead market model, uniform pricing model, lacks of transparency in market which may be obstacle for Turkish market participants to participate in Day Ahead Market. Transparency indicates that bids of companies are not seen by other market participants. Comparison of currently applied uniform pricing and continuous trading is done in Chapter 4. Moreover, Turkish Day Ahead Market system does not have so much private investors in production phase. Production is done by with a percentage of 55% by state owned companies. Thus, Turkish Day Ahead Market does not expose reference pricing, although Day Ahead Market has an aim of occurrence of reference pricing.

In Chapter 6, written MATLAB software is depicted and run. 3 different comprehensive examples are studied in Chapter 6 regarding market splitting with written software. In first example, the current Turkish Day Ahead Market system is implemented on a specific hour. Since current Turkish Day Ahead Market system do not implement market splitting, first example includes calculation of market clearing price of electricity, KPTF, prices has to be incurred on market participants and resultant dispatch.

In second example of Chapter 6 depicts a suggested model for Turkish Day Ahead Market system which includes market splitting method. In market splitting example, Turkey is divided into two regions. By means of developed software, regional market prices, NPTF, has to be incurred on each market participant and resultant dispatch are calculated with a specific transmission limit on transmission line between two regions. In third example, bids and companies are fixed, while transmission line limit is increased. Chapter 6 examples are based on unrealistic market bids and Chapter 6 examples aims to prove the superiority of market splitting method over current model applied in Turkey.

Chapter 7 is the performance analysis of developed software with real data obtained by MFSC. Performance of developed software is high and deviation from real market price is lower than 8%. Error of developed software is around 5%. Hence, Chapter 7 proves that developed software has capability of handling real market data.

Since Chapter 7 utilizes real market data, Chapter 7 includes simulation of current Turkish day ahead market. Moreover, proposed model is also simulated in Chapter 7 via developed software. Therefore, it is proved that Turkish electricity market has to implement market splitting in order to manage congestions; which decrease prices as transmission lines are improved.

In conclusion, it is concluded that without market splitting system seems to be in balance but in reality, since transmission congestions are not taken into consideration, actual balancing in the system do not occur, although whole system seems to be in balance. Therefore, in some regions, scarcity of electricity can occur; whereas in some regions, surplus of energy can occur. Such a condition has happened in Mediterranean region of Turkey during summer

season in 2012 where energy demand is in top level. Near soon, Thracian region of Turkey suffered the same problem. However, if market splitting has been applied, Mediterranean and Thracian regions of Turkey would not have scarcity of electricity. Case studies in Chapter 6 prove that market splitting manages transmission congestions.

On the other hand, adoption of market splitting brings system balance physically, yet regional price differences occur. In day ahead markets which adopt market splitting, transmission capacities are taken into consideration. Thus, surplus or scarcity of electricity does not occur. It is shown that whole grid system tend to be more reliable. However, if market splitting is not applied, system becomes less reliable. Since market splitting emerge different zonal prices, an amount of surplus of money also emerge. Excess of market payments are depicted as a result of simulations performed in Chapter 6 and Chapter 7 examples. This excess money can be used for upgrading infrastructure between zones which will help to decrease price differences among regions. Therefore, after some time, system will tend to be ideal. In ideal case, system is desired to have only 1 price, KPTF, all NPTF are equal in market splitting model. However, in reality transmission capacities of grids limits transmission of energy. Thus, main aim is to have the difference of zonal prices at minimum level. This is acquired by improving the capacity of grids. As a result, it is offered that adoption of market splitting model into Turkish Day Ahead Market System is required to make system more reliable and to manage transmission congestions.

8.2 Future Work

Although European Union Countries are physically integrated to each other, European Union countries have different separated markets as of 2013 September. However, it is planned that European Union countries will integrate their electricity market. Hence, market coupling system will emerge. Turkish electricity is physically connected to the European Union. Therefore, in future, for a more integrated electricity market structure and physical interconnections with European countries, Turkish day ahead market structure can be widened and studied in detail by integrating Turkish electricity market to the European electricity market. This will improve reliability of system. Therefore, market coupling with European Union in Turkish electricity market can be studied as future work.

In addition, for the current developed software, block bids are not handled with high success rate. Therefore, performance of developed software can be improved from block bids manner. This will improve the accuracy of developed software. Another improvement for the developed software is related with handling of many zones. In cases of 5 or more zones, software encounters problems and gives inaccurate results.

Market manipulations are one of the problems of current Turkish electricity market. Hence, developed software can be improved by adding intelligent mechanism to the developed software. This intelligent mechanism can be responsible for detecting the market manipulations by observing the submitted bids. Hence, unfair profits can be blocked directly via developed software. As a result, much fair competition on the market can be achieved.

REFERENCES

- [1] Krause, T., 2005, "Congestion Management in Liberalized Electricity Markets-Theoretical Concepts and International Application", EEH – power systems laboratory, Swiss Federal Institute of Technology Zurich.
- [2] Hogan, W., 1999, "Transmission Congestion: The Nodal-Zonal Debate Revisited" Harvard University, John F. Kennedy School of Government, Center for Business and Government.
- [3] Xingwang, M., Sun, D.I., Kwok, W. C., 2003, " Evolution Toward Standardized Market Design", IEEE Transactions on Power Systems, 18, 460-469.
- [4] T.Wu and Z.Alaywan, 2004, "Transitioning the California Market from a Zonal to a Nodal Framework: An Operational Perspective", In: Proceedings of the Power Systems Conference and Exposition, 2, 862-867.
- [5] Borenstein, S., Bushnell, J., Wolak, F., 2000, "Diagnosing Market Power in California's Deregulated Wholesale Electricity Market", PWP-064, University of California Energy Institute.
- [6] Johnsen, T.A., Verma, S.K., Wolfram, C., 1999, "Zonal Pricing and Demand-Side Bidding in the Norwegian Electricity Market. PWP-063, University of California Energy Institute
- [7] Ockenfels, A., Grimm, V., Zoettl, G., 2008, Electricity Market Design
- [8] Onaiwu, E., How Does Bilateral Trading Differ From Electricity Pooling
- [9] Brinckerhoff, P.,2011, Electricity Generation Cost Model, Department of Energy and Climate Change, UK
- [10] Love, L., 2000, The Single Buyer Model, The World Bank Group
- [11] Jung, Y.B., Kim, K.S., Park, C.H., Yoon, Y.B., 2012, A Study of Optimization Modeling to the Generation Cost under the Stable Operation of Power System, Journal of International Council on Electrical Engineering Vol. 2, No. 2, pp. 208~214
- [12] Dananiel, S. K., Strbac, G., 2004 Fundamentals of Power System Economics, John Wiley & Sons Ltd.

- [13] Osman Sevaiođlu, 2011, EE 710 Lecture Notes
- [14] Shahidehpour, M., Yamin, H., Li, Z., 2002, Market Operations in Electric Power Systems, John Willey & Sons, Inc.
- [15] T.C. Elektrik Piyasası Dengeleme ve Uzlařtırma Yönetmeliđi
- [16] María, N.S., 2010, Day Ahead Electricity Market, Universidad Pontificia Comillas, Madrid
- [17] Hogan, W.W, 1993, A competitive Electricity Market Model
- [18] T.C. Elektrik Piyasası Kanunu
- [19] Elektrik Piyasaları İşletme Dairesi Başkanlığı, 2013, Gün Öncesi Piyasası Kullanıcı Klavuzu
- [20] Accenture Türkiye, 2013, Türkiye Elektrik Piyasası'nda Elektrik Ticareti
- [21] Ogun, A., 2011, Gün Öncesi Piyasası
- [22] Stoft, S., 2002, Power System Economics, Designing Market for Electricity, IEEE Press, A John Wiley & Sons, INC
- [23] <https://dgpys.pmum.gov.tr/dgpys/>, Last visited in 28 September 2013

APPENDIX A

DAY AHEAD MARKET MODELS IN EUROPEAN COUNTRIES

A.1 Nord Pool	Norway, Sweden, Finland, Denmark																																																																								
<p>Bidding limitations</p> <table style="width: 100%; border: none;"> <tr> <td style="width: 50%; vertical-align: top; padding-right: 20px;"> <p><i>Price</i></p> <ul style="list-style-type: none"> Minimum: 0 €/MWh Maximum: 2000 €/MWh Steps: 64 </td> <td style="width: 50%; vertical-align: top;"> <p><i>Volume</i></p> <ul style="list-style-type: none"> Positive (purchase): decreasing with increasing prices Negative (sell): increasing with decreasing prices Positive and negative allowed in one bid: YES </td> </tr> </table>		<p><i>Price</i></p> <ul style="list-style-type: none"> Minimum: 0 €/MWh Maximum: 2000 €/MWh Steps: 64 	<p><i>Volume</i></p> <ul style="list-style-type: none"> Positive (purchase): decreasing with increasing prices Negative (sell): increasing with decreasing prices Positive and negative allowed in one bid: YES 																																																																						
<p><i>Price</i></p> <ul style="list-style-type: none"> Minimum: 0 €/MWh Maximum: 2000 €/MWh Steps: 64 	<p><i>Volume</i></p> <ul style="list-style-type: none"> Positive (purchase): decreasing with increasing prices Negative (sell): increasing with decreasing prices Positive and negative allowed in one bid: YES 																																																																								
<p>DAM Auction Trading: YES</p> <p>SINGLE BIDS</p> <ul style="list-style-type: none"> Hourly Bid: YES Price-independent Hourly Bid: NO <p>COMPLEX BIDS</p> <ul style="list-style-type: none"> Flexible Hourly Bid: YES Simple Block Bid <ol style="list-style-type: none"> User-defined: YES (min 3 hours/block, max 50 blocks/day) System-defined: daily (YES), weekend (NO), week (NO) <div style="text-align: center; margin: 10px 0;"> <table border="1" style="margin: auto; border-collapse: collapse;"> <tr style="background-color: #ADD8E6;"> <th colspan="24" style="padding: 2px;">Daily</th> </tr> <tr> <td style="padding: 2px;">1</td><td style="padding: 2px;">2</td><td style="padding: 2px;">3</td><td style="padding: 2px;">4</td><td style="padding: 2px;">5</td><td style="padding: 2px;">6</td><td style="padding: 2px;">7</td><td style="padding: 2px;">8</td><td style="padding: 2px;">9</td><td style="padding: 2px;">10</td><td style="padding: 2px;">11</td><td style="padding: 2px;">12</td><td style="padding: 2px;">13</td><td style="padding: 2px;">14</td><td style="padding: 2px;">15</td><td style="padding: 2px;">16</td><td style="padding: 2px;">17</td><td style="padding: 2px;">18</td><td style="padding: 2px;">19</td><td style="padding: 2px;">20</td><td style="padding: 2px;">21</td><td style="padding: 2px;">22</td><td style="padding: 2px;">23</td><td style="padding: 2px;">24</td> </tr> <tr> <td colspan="24" style="text-align: center; padding: 2px;">Base (price-independent)</td> </tr> </table> </div> <ul style="list-style-type: none"> Linked Block Bids: YES (max 3 blocks, all must be only sales or only purchase) Convertible Block Bid: YES 		Daily																								1	2	3	4	5	6	7	8	9	10	11	12	13	14	15	16	17	18	19	20	21	22	23	24	Base (price-independent)																							
Daily																																																																									
1	2	3	4	5	6	7	8	9	10	11	12	13	14	15	16	17	18	19	20	21	22	23	24																																																		
Base (price-independent)																																																																									
<p>DAM Continuous Trading: NO</p> <ul style="list-style-type: none"> Simple Block Bid <ol style="list-style-type: none"> User-defined: NO System-defined: daily (NO), weekend (NO), week (NO) 																																																																									

Figure A1 Nord Pool Day Ahead Market Structure [16]

A.2 EPEX Germany	Germany																																																																																																																																								
<p>Bidding limitations</p> <table border="0"> <tr> <td style="vertical-align: top;"> <p><i>Price</i></p> <ul style="list-style-type: none"> • Minimum: -3000 €/MWh • Maximum: 3000 €/MWh • Steps: 250 </td> <td style="vertical-align: top;"> <p><i>Volume</i></p> <ul style="list-style-type: none"> • Positive (purchase): decreasing with increasing prices • Negative (sell): increasing with decreasing prices • Positive and negative allowed in one bid: YES </td> </tr> </table>		<p><i>Price</i></p> <ul style="list-style-type: none"> • Minimum: -3000 €/MWh • Maximum: 3000 €/MWh • Steps: 250 	<p><i>Volume</i></p> <ul style="list-style-type: none"> • Positive (purchase): decreasing with increasing prices • Negative (sell): increasing with decreasing prices • Positive and negative allowed in one bid: YES 																																																																																																																																						
<p><i>Price</i></p> <ul style="list-style-type: none"> • Minimum: -3000 €/MWh • Maximum: 3000 €/MWh • Steps: 250 	<p><i>Volume</i></p> <ul style="list-style-type: none"> • Positive (purchase): decreasing with increasing prices • Negative (sell): increasing with decreasing prices • Positive and negative allowed in one bid: YES 																																																																																																																																								
<p>DAM Auction Trading: YES</p> <p>SINGLE BIDS</p> <ul style="list-style-type: none"> • Hourly Bid: YES • Price-independent Hourly Bid: YES <p>COMPLEX BIDS</p> <ul style="list-style-type: none"> • Flexible Hourly Bid: NO • Simple Block Bid (max 300 MWh/block, max 45 blocks/day) <ul style="list-style-type: none"> c) User-defined: YES (min 2 hours/block) d) System-defined: daily (YES), weekend (NO), week (NO) <table border="1" data-bbox="416 987 1257 1171"> <thead> <tr> <th colspan="24">Daily</th> </tr> </thead> <tbody> <tr> <td>1</td><td>2</td><td>3</td><td>4</td><td>5</td><td>6</td><td>7</td><td>8</td><td>9</td><td>10</td><td>11</td><td>12</td><td>13</td><td>14</td><td>15</td><td>16</td><td>17</td><td>18</td><td>19</td><td>20</td><td>21</td><td>22</td><td>23</td><td>24</td> </tr> <tr> <td colspan="24">Baseload</td> </tr> <tr> <td colspan="24">Peakload</td> </tr> <tr> <td colspan="4">Night</td> <td colspan="4">Morning</td> <td colspan="4">High Noon</td> <td colspan="4">Afternoon</td> <td colspan="4">Evening</td> </tr> <tr> <td colspan="4">Off-Peak 1</td> <td colspan="8">Business</td> <td colspan="4">Rush Hour</td> <td colspan="4">Off-Peak 2</td> </tr> </tbody> </table> <ul style="list-style-type: none"> • Linked Block Bids: NO • Convertible Block Bid: NO 		Daily																								1	2	3	4	5	6	7	8	9	10	11	12	13	14	15	16	17	18	19	20	21	22	23	24	Baseload																								Peakload																								Night				Morning				High Noon				Afternoon				Evening				Off-Peak 1				Business								Rush Hour				Off-Peak 2			
Daily																																																																																																																																									
1	2	3	4	5	6	7	8	9	10	11	12	13	14	15	16	17	18	19	20	21	22	23	24																																																																																																																		
Baseload																																																																																																																																									
Peakload																																																																																																																																									
Night				Morning				High Noon				Afternoon				Evening																																																																																																																									
Off-Peak 1				Business								Rush Hour				Off-Peak 2																																																																																																																									
<p>DAM Continuous Trading: NO</p> <ul style="list-style-type: none"> • Simple Block Bid <ul style="list-style-type: none"> a) User-defined: NO b) System-defined: daily (NO), weekend (NO), week (NO) 																																																																																																																																									

Figure A2 EPEX Germany Day Ahead Market Structure [16]

A.3 EPEX France	France																																																																																																																																																																								
<p>Bidding limitations</p> <table border="0"> <tr> <td style="vertical-align: top;"> <p><i>Price</i></p> <ul style="list-style-type: none"> • Minimum: 0.01 €/MWh • Maximum: 3000 €/MWh • Steps: 256 </td> <td style="vertical-align: top;"> <p><i>Volume</i></p> <ul style="list-style-type: none"> • Positive (purchase): decreasing with increasing prices • Negative (sell): increasing with decreasing prices • Positive and negative allowed in one bid: YES </td> </tr> </table>		<p><i>Price</i></p> <ul style="list-style-type: none"> • Minimum: 0.01 €/MWh • Maximum: 3000 €/MWh • Steps: 256 	<p><i>Volume</i></p> <ul style="list-style-type: none"> • Positive (purchase): decreasing with increasing prices • Negative (sell): increasing with decreasing prices • Positive and negative allowed in one bid: YES 																																																																																																																																																																						
<p><i>Price</i></p> <ul style="list-style-type: none"> • Minimum: 0.01 €/MWh • Maximum: 3000 €/MWh • Steps: 256 	<p><i>Volume</i></p> <ul style="list-style-type: none"> • Positive (purchase): decreasing with increasing prices • Negative (sell): increasing with decreasing prices • Positive and negative allowed in one bid: YES 																																																																																																																																																																								
<p>DAM Auction Trading: YES</p> <p>SINGLE BIDS</p> <ul style="list-style-type: none"> • Hourly Bid: YES • Price-independent Hourly Bid: YES <p>COMPLEX BIDS</p> <ul style="list-style-type: none"> • Flexible Hourly Bid: YES (max: 3 bids/day) • Simple Block Bid (max 200 MWh/block, max 8 bids / block type) <ul style="list-style-type: none"> e) User-defined: YES (min 4 hours/block) f) System-defined: daily (YES), weekend (NO), week (NO) <table border="1" style="width: 100%; border-collapse: collapse; text-align: center;"> <thead> <tr style="background-color: #ADD8E6;"> <th colspan="24">Daily</th> </tr> <tr> <th>1</th><th>2</th><th>3</th><th>4</th><th>5</th><th>6</th><th>7</th><th>8</th><th>9</th><th>10</th><th>11</th><th>12</th><th>13</th><th>14</th><th>15</th><th>16</th><th>17</th><th>18</th><th>19</th><th>20</th><th>21</th><th>22</th><th>23</th><th>24</th> </tr> </thead> <tbody> <tr> <td colspan="24">Baseload</td> </tr> <tr> <td colspan="24">Peakload</td> </tr> <tr> <td colspan="4">Block 1-4</td> <td colspan="4">Block 5-8</td> <td colspan="4">Block 9-12</td> <td colspan="4">Block 13-16</td> <td colspan="4">Block 17-20</td> <td colspan="4">Block 21-24</td> </tr> <tr> <td colspan="8">Block 1-8</td> <td colspan="8">Block 9-16</td> <td colspan="8"></td> </tr> <tr> <td colspan="6">Block 1-6</td> <td colspan="18"></td> </tr> </tbody> </table> <ul style="list-style-type: none"> • Linked Block Bids: NO • Convertible Block Bid: NO 		Daily																								1	2	3	4	5	6	7	8	9	10	11	12	13	14	15	16	17	18	19	20	21	22	23	24	Baseload																								Peakload																								Block 1-4				Block 5-8				Block 9-12				Block 13-16				Block 17-20				Block 21-24				Block 1-8								Block 9-16																Block 1-6																							
Daily																																																																																																																																																																									
1	2	3	4	5	6	7	8	9	10	11	12	13	14	15	16	17	18	19	20	21	22	23	24																																																																																																																																																		
Baseload																																																																																																																																																																									
Peakload																																																																																																																																																																									
Block 1-4				Block 5-8				Block 9-12				Block 13-16				Block 17-20				Block 21-24																																																																																																																																																					
Block 1-8								Block 9-16																																																																																																																																																																	
Block 1-6																																																																																																																																																																									
<p>DAM Continuous Trading: YES</p> <ul style="list-style-type: none"> • Simple Block Bid <ul style="list-style-type: none"> a) User-defined: NO b) System-defined: daily (YES), weekend (NO), week (NO) <p>Order types: "Standard", "Market-to-Limit", "Must-be-filled"</p> <p>Execution types: "All-or-None", "All-or-Some", "Hidden Quantities (Iceberg Order)"</p> <table border="1" style="width: 100%; border-collapse: collapse; text-align: center;"> <thead> <tr style="background-color: #ADD8E6;"> <th colspan="24">Daily</th> </tr> <tr> <th>1</th><th>2</th><th>3</th><th>4</th><th>5</th><th>6</th><th>7</th><th>8</th><th>9</th><th>10</th><th>11</th><th>12</th><th>13</th><th>14</th><th>15</th><th>16</th><th>17</th><th>18</th><th>19</th><th>20</th><th>21</th><th>22</th><th>23</th><th>24</th> </tr> </thead> <tbody> <tr> <td colspan="24">Baseload</td> </tr> <tr> <td colspan="24">Peakload</td> </tr> <tr> <td colspan="4">Block 1-4</td> <td colspan="4">Block 5-8</td> <td colspan="4">Block 9-12</td> <td colspan="4">Block 13-16</td> <td colspan="4">Block 17-20</td> <td colspan="4">Block 21-24</td> </tr> <tr> <td colspan="8">Block 1-8</td> <td colspan="8">Block 9-16</td> <td colspan="8"></td> </tr> <tr> <td colspan="6">Block 1-6</td> <td colspan="18"></td> </tr> </tbody> </table>		Daily																								1	2	3	4	5	6	7	8	9	10	11	12	13	14	15	16	17	18	19	20	21	22	23	24	Baseload																								Peakload																								Block 1-4				Block 5-8				Block 9-12				Block 13-16				Block 17-20				Block 21-24				Block 1-8								Block 9-16																Block 1-6																							
Daily																																																																																																																																																																									
1	2	3	4	5	6	7	8	9	10	11	12	13	14	15	16	17	18	19	20	21	22	23	24																																																																																																																																																		
Baseload																																																																																																																																																																									
Peakload																																																																																																																																																																									
Block 1-4				Block 5-8				Block 9-12				Block 13-16				Block 17-20				Block 21-24																																																																																																																																																					
Block 1-8								Block 9-16																																																																																																																																																																	
Block 1-6																																																																																																																																																																									

Figure A3 EPEX France Day Ahead Market Structure [16]

A.4 APX Power NL	Netherlands		
<p>Bidding limitations</p> <table border="0"> <tr> <td data-bbox="213 465 635 600"> <p><i>Price</i></p> <ul style="list-style-type: none"> • Minimum: 0.01 €/MWh • Maximum: 3000 €/MWh • Steps: 25 </td> <td data-bbox="635 465 1264 600"> <p><i>Volume</i></p> <ul style="list-style-type: none"> • Positive (purchase): decreasing with increasing prices • Negative (sell): increasing with decreasing prices • Positive and negative allowed in one bid: YES </td> </tr> </table>		<p><i>Price</i></p> <ul style="list-style-type: none"> • Minimum: 0.01 €/MWh • Maximum: 3000 €/MWh • Steps: 25 	<p><i>Volume</i></p> <ul style="list-style-type: none"> • Positive (purchase): decreasing with increasing prices • Negative (sell): increasing with decreasing prices • Positive and negative allowed in one bid: YES
<p><i>Price</i></p> <ul style="list-style-type: none"> • Minimum: 0.01 €/MWh • Maximum: 3000 €/MWh • Steps: 25 	<p><i>Volume</i></p> <ul style="list-style-type: none"> • Positive (purchase): decreasing with increasing prices • Negative (sell): increasing with decreasing prices • Positive and negative allowed in one bid: YES 		
<p>DAM Auction Trading: YES</p> <p>SINGLE BIDS</p> <ul style="list-style-type: none"> • Hourly Bid: YES • Price-independent Hourly Bid: YES <p>COMPLEX BIDS</p> <ul style="list-style-type: none"> • Flexible Hourly Bid: NO • Simple Block Bid (Execution type: “All-or-Nothing”) <ul style="list-style-type: none"> g) User-defined: YES (min 2 hours/block) h) System-defined: daily (NO), weekend (NO), week (NO) • Linked Block Bids: NO • Convertible Block Bid: NO 			
<p>DAM Continuous Trading: NO</p> <ul style="list-style-type: none"> • Simple Block Bid <ul style="list-style-type: none"> a) User-defined: NO b) System-defined: daily (NO), weekend (NO), week (NO) 			

Figure A4 APX Power Netherlands Day Ahead Market Structure [16]

A.5 BelPEX	Belgium																																																																																																																																																																								
<p>Bidding limitations</p> <table border="0"> <tr> <td style="vertical-align: top;"> <p><i>Price</i></p> <ul style="list-style-type: none"> • Minimum: 0.01 €/MWh • Maximum: 3000 €/MWh • Steps: 256 </td> <td style="vertical-align: top;"> <p><i>Volume</i></p> <ul style="list-style-type: none"> • Positive (purchase): decreasing with increasing prices • Negative (sell): increasing with decreasing prices • Positive and negative allowed in one bid: YES </td> </tr> </table>		<p><i>Price</i></p> <ul style="list-style-type: none"> • Minimum: 0.01 €/MWh • Maximum: 3000 €/MWh • Steps: 256 	<p><i>Volume</i></p> <ul style="list-style-type: none"> • Positive (purchase): decreasing with increasing prices • Negative (sell): increasing with decreasing prices • Positive and negative allowed in one bid: YES 																																																																																																																																																																						
<p><i>Price</i></p> <ul style="list-style-type: none"> • Minimum: 0.01 €/MWh • Maximum: 3000 €/MWh • Steps: 256 	<p><i>Volume</i></p> <ul style="list-style-type: none"> • Positive (purchase): decreasing with increasing prices • Negative (sell): increasing with decreasing prices • Positive and negative allowed in one bid: YES 																																																																																																																																																																								
<p>DAM Auction Trading: YES</p> <p>SINGLE BIDS</p> <ul style="list-style-type: none"> • Hourly Bid: YES • Price-independent Hourly Bid: NO <p>COMPLEX BIDS</p> <ul style="list-style-type: none"> • Flexible Hourly Bid: NO • Simple Block Bid (max 50 MW/block, max 1000 MW/hour/participant) <ul style="list-style-type: none"> i) User-defined: YES j) System-defined: daily (NO), weekend (NO), week (NO) • Linked Block Bids: NO • Convertible Block Bid: NO 																																																																																																																																																																									
<p>DAM Continuous Trading: YES</p> <ul style="list-style-type: none"> • Simple Block Bid <ul style="list-style-type: none"> a) User-defined: NO b) System-defined: daily (YES), weekend (YES), week (NO) <p>Order types: "Standard", "Market Order"</p> <table border="1" style="margin-left: auto; margin-right: auto;"> <tr style="background-color: #ADD8E6;"> <th colspan="24">Daily</th> </tr> <tr> <td>1</td><td>2</td><td>3</td><td>4</td><td>5</td><td>6</td><td>7</td><td>8</td><td>9</td><td>10</td><td>11</td><td>12</td><td>13</td><td>14</td><td>15</td><td>16</td><td>17</td><td>18</td><td>19</td><td>20</td><td>21</td><td>22</td><td>23</td><td>24</td> </tr> <tr> <td colspan="24" style="text-align: center;">Baseload</td> </tr> <tr> <td colspan="8" style="text-align: center;">Off-peak</td> <td colspan="8" style="text-align: center;">Peakload</td> <td colspan="8" style="text-align: center;">Off-peak</td> </tr> </table> <table border="1" style="margin-left: auto; margin-right: auto;"> <tr style="background-color: #ADD8E6;"> <th colspan="24">Weekend (x2)</th> </tr> <tr> <td>1</td><td>2</td><td>3</td><td>4</td><td>5</td><td>6</td><td>7</td><td>8</td><td>9</td><td>10</td><td>11</td><td>12</td><td>13</td><td>14</td><td>15</td><td>16</td><td>17</td><td>18</td><td>19</td><td>20</td><td>21</td><td>22</td><td>23</td><td>24</td> </tr> <tr> <td colspan="24" style="text-align: center;">Weekend</td> </tr> </table>		Daily																								1	2	3	4	5	6	7	8	9	10	11	12	13	14	15	16	17	18	19	20	21	22	23	24	Baseload																								Off-peak								Peakload								Off-peak								Weekend (x2)																								1	2	3	4	5	6	7	8	9	10	11	12	13	14	15	16	17	18	19	20	21	22	23	24	Weekend																							
Daily																																																																																																																																																																									
1	2	3	4	5	6	7	8	9	10	11	12	13	14	15	16	17	18	19	20	21	22	23	24																																																																																																																																																		
Baseload																																																																																																																																																																									
Off-peak								Peakload								Off-peak																																																																																																																																																									
Weekend (x2)																																																																																																																																																																									
1	2	3	4	5	6	7	8	9	10	11	12	13	14	15	16	17	18	19	20	21	22	23	24																																																																																																																																																		
Weekend																																																																																																																																																																									

Figure A5 BelPEX Belgium Day Ahead Market Structure [16]

A.6 GME	Italy		
<p>Bidding limitations</p> <table border="0"> <tr> <td data-bbox="225 405 635 517"> <i>Price</i> <ul style="list-style-type: none"> • Minimum: 0 €/MWh • Maximum: 3000 €/MWh • Steps: 25 </td> <td data-bbox="651 405 1249 517"> <i>Volume</i> <ul style="list-style-type: none"> • Positive </td> </tr> </table>		<i>Price</i> <ul style="list-style-type: none"> • Minimum: 0 €/MWh • Maximum: 3000 €/MWh • Steps: 25 	<i>Volume</i> <ul style="list-style-type: none"> • Positive
<i>Price</i> <ul style="list-style-type: none"> • Minimum: 0 €/MWh • Maximum: 3000 €/MWh • Steps: 25 	<i>Volume</i> <ul style="list-style-type: none"> • Positive 		
<p>DAM Auction Trading: YES</p> <p>SINGLE BIDS</p> <ul style="list-style-type: none"> • Hourly Bid: YES • Price-independent Hourly Bid: YES <p>COMPLEX BIDS: NO</p>			
<p>DAM Continuous Trading: NO</p> <ul style="list-style-type: none"> • Simple Block Bid <ul style="list-style-type: none"> a) User-defined: NO b) System-defined: daily (NO), weekend (NO), week (NO) 			

Figure A6 GME Italy Day Ahead Market Structure [16]

A.7 APX Power UK	UK																																																																																																																																																																																																																																																																																																																																				
<p>DAM Auction Trading: YES</p> <p>SINGLE BIDS</p> <ul style="list-style-type: none"> Hourly Bid: YES Price-independent Hourly Bid: NO <p>COMPLEX BIDS NO</p>																																																																																																																																																																																																																																																																																																																																					
<p>DAM Continuous Trading: YES</p> <ul style="list-style-type: none"> Simple Block Bid <ul style="list-style-type: none"> a) User-defined: NO b) System-defined: daily (YES), weekend (YES), week (YES) <table border="1" style="margin-left: 40px;"> <thead> <tr style="background-color: #ADD8E6;"> <th colspan="24">Daily</th> </tr> </thead> <tbody> <tr> <td>1</td><td>2</td><td>3</td><td>4</td><td>5</td><td>6</td><td>7</td><td>8</td><td>9</td><td>10</td><td>11</td><td>12</td><td>13</td><td>14</td><td>15</td><td>16</td><td>17</td><td>18</td><td>19</td><td>20</td><td>21</td><td>22</td><td>23</td><td>24</td> </tr> <tr> <td colspan="24" style="text-align: center;">Base</td> </tr> <tr> <td colspan="6" style="text-align: center;">Off-Peak</td> <td colspan="12" style="text-align: center;">Peak</td> <td colspan="6" style="text-align: center;">Off-Peak</td> </tr> <tr> <td colspan="6" style="text-align: center;">Overnight</td> <td colspan="18" style="text-align: center;">Extended Peak</td> </tr> <tr style="background-color: #808080;"> <td colspan="12" style="text-align: center;">Block 3+4</td> <td colspan="12"></td> </tr> </tbody> </table> <table border="1" style="margin-left: 40px;"> <thead> <tr style="background-color: #ADD8E6;"> <th colspan="24">Weekend (x2)</th> </tr> </thead> <tbody> <tr> <td>1</td><td>2</td><td>3</td><td>4</td><td>5</td><td>6</td><td>7</td><td>8</td><td>9</td><td>10</td><td>11</td><td>12</td><td>13</td><td>14</td><td>15</td><td>16</td><td>17</td><td>18</td><td>19</td><td>20</td><td>21</td><td>22</td><td>23</td><td>24</td> </tr> <tr> <td colspan="24" style="text-align: center;">Base</td> </tr> </tbody> </table> <table border="1" style="margin-left: 40px;"> <thead> <tr style="background-color: #ADD8E6;"> <th colspan="24">Week</th> </tr> </thead> <tbody> <tr> <td>1</td><td>2</td><td>3</td><td>4</td><td>5</td><td>6</td><td>7</td><td>8</td><td>9</td><td>10</td><td>11</td><td>12</td><td>13</td><td>14</td><td>15</td><td>16</td><td>17</td><td>18</td><td>19</td><td>20</td><td>21</td><td>22</td><td>23</td><td>24</td> </tr> <tr> <td colspan="24" style="text-align: center;">Base (x7)</td> </tr> <tr style="background-color: #808080;"> <td colspan="12"></td> <td colspan="12" style="text-align: center;">Peak (x5)</td> <td colspan="12"></td> </tr> </tbody> </table>		Daily																								1	2	3	4	5	6	7	8	9	10	11	12	13	14	15	16	17	18	19	20	21	22	23	24	Base																								Off-Peak						Peak												Off-Peak						Overnight						Extended Peak																		Block 3+4																								Weekend (x2)																								1	2	3	4	5	6	7	8	9	10	11	12	13	14	15	16	17	18	19	20	21	22	23	24	Base																								Week																								1	2	3	4	5	6	7	8	9	10	11	12	13	14	15	16	17	18	19	20	21	22	23	24	Base (x7)																																				Peak (x5)																							
Daily																																																																																																																																																																																																																																																																																																																																					
1	2	3	4	5	6	7	8	9	10	11	12	13	14	15	16	17	18	19	20	21	22	23	24																																																																																																																																																																																																																																																																																																														
Base																																																																																																																																																																																																																																																																																																																																					
Off-Peak						Peak												Off-Peak																																																																																																																																																																																																																																																																																																																			
Overnight						Extended Peak																																																																																																																																																																																																																																																																																																																															
Block 3+4																																																																																																																																																																																																																																																																																																																																					
Weekend (x2)																																																																																																																																																																																																																																																																																																																																					
1	2	3	4	5	6	7	8	9	10	11	12	13	14	15	16	17	18	19	20	21	22	23	24																																																																																																																																																																																																																																																																																																														
Base																																																																																																																																																																																																																																																																																																																																					
Week																																																																																																																																																																																																																																																																																																																																					
1	2	3	4	5	6	7	8	9	10	11	12	13	14	15	16	17	18	19	20	21	22	23	24																																																																																																																																																																																																																																																																																																														
Base (x7)																																																																																																																																																																																																																																																																																																																																					
												Peak (x5)																																																																																																																																																																																																																																																																																																																									

Figure A7 APX Power United Kingdom Day Ahead Market Structure [16]

A.8 N2EX	UK																																																																																																																																																																																																																																																																																																																																																																																																																												
<p>Bidding limitations</p> <p><i>Price</i></p> <ul style="list-style-type: none"> • Minimum: 0 GBP/MWh • Maximum: 2000 GBP/MWh • Steps: 200 <p><i>Volume</i></p> <ul style="list-style-type: none"> • Positive (purchase): decreasing with increasing prices • Negative (sell): increasing with decreasing prices • Positive and negative allowed in one bid: YES 																																																																																																																																																																																																																																																																																																																																																																																																																													
<p>DAM Auction Trading: YES</p> <p>SINGLE BIDS</p> <ul style="list-style-type: none"> • Hourly Bid: YES • Price-independent Hourly Bid: NO <p>COMPLEX BIDS</p> <ul style="list-style-type: none"> • Flexible Hourly Bid: YES (max: 3 bids/day) • Simple Block Bid <ul style="list-style-type: none"> a) User-defined: YES (min 2 hours/block, max 50 MWh/block, max 20 blocks/day) b) System-defined: daily (YES), weekend (NO), week (NO) <table border="1" style="margin-left: 40px;"> <thead> <tr> <th colspan="24" style="background-color: #ADD8E6;">Daily</th> </tr> </thead> <tbody> <tr> <td>1</td><td>2</td><td>3</td><td>4</td><td>5</td><td>6</td><td>7</td><td>8</td><td>9</td><td>10</td><td>11</td><td>12</td><td>13</td><td>14</td><td>15</td><td>16</td><td>17</td><td>18</td><td>19</td><td>20</td><td>21</td><td>22</td><td>23</td><td>24</td> </tr> <tr> <td colspan="24" style="text-align: center;">Base (price-independent)</td> </tr> </tbody> </table> <ul style="list-style-type: none"> • Linked Block Bids: YES (max 3 blocks, all must be only sales or only purchase) • Convertible Block Bid: NO 		Daily																								1	2	3	4	5	6	7	8	9	10	11	12	13	14	15	16	17	18	19	20	21	22	23	24	Base (price-independent)																																																																																																																																																																																																																																																																																																																																																																											
Daily																																																																																																																																																																																																																																																																																																																																																																																																																													
1	2	3	4	5	6	7	8	9	10	11	12	13	14	15	16	17	18	19	20	21	22	23	24																																																																																																																																																																																																																																																																																																																																																																																																						
Base (price-independent)																																																																																																																																																																																																																																																																																																																																																																																																																													
<p>DAM Continuous Trading: YES</p> <ul style="list-style-type: none"> • Simple Block Bid (Execution types: “Fill”, “Fill or Kill”, “Fill and Kill”, “Stop Order”) <ul style="list-style-type: none"> a) User-defined: NO b) System-defined: daily (YES), weekend (YES), week (YES) <table border="1" style="margin-left: 40px;"> <thead> <tr> <th colspan="24" style="background-color: #ADD8E6;">Daily</th> </tr> </thead> <tbody> <tr> <td>1</td><td>2</td><td>3</td><td>4</td><td>5</td><td>6</td><td>7</td><td>8</td><td>9</td><td>10</td><td>11</td><td>12</td><td>13</td><td>14</td><td>15</td><td>16</td><td>17</td><td>18</td><td>19</td><td>20</td><td>21</td><td>22</td><td>23</td><td>24</td> </tr> <tr> <td colspan="24" style="text-align: center;">Base</td> </tr> <tr> <td colspan="6" style="text-align: center;">Off-Peak</td> <td colspan="12" style="text-align: center;">Peak</td> <td colspan="6" style="text-align: center;">Off-Peak</td> </tr> <tr> <td colspan="6" style="text-align: center;">Overnight</td> <td colspan="18" style="text-align: center;">Extended Peak</td> </tr> <tr> <td colspan="3" style="text-align: center;">Block 1</td> <td colspan="3" style="text-align: center;">Block 2</td> <td colspan="4" style="text-align: center;">Block 3</td> <td colspan="4" style="text-align: center;">Block 4</td> <td colspan="4" style="text-align: center;">Block 5</td> <td colspan="6" style="text-align: center;">Block 6</td> </tr> <tr> <td colspan="6" style="background-color: #cccccc;"></td> <td colspan="12" style="text-align: center;">Block 3+4</td> <td colspan="6" style="background-color: #cccccc;"></td> </tr> </tbody> </table> <table border="1" style="margin-left: 40px;"> <thead> <tr> <th colspan="24" style="background-color: #ADD8E6;">Weekend (x2)</th> </tr> </thead> <tbody> <tr> <td>1</td><td>2</td><td>3</td><td>4</td><td>5</td><td>6</td><td>7</td><td>8</td><td>9</td><td>10</td><td>11</td><td>12</td><td>13</td><td>14</td><td>15</td><td>16</td><td>17</td><td>18</td><td>19</td><td>20</td><td>21</td><td>22</td><td>23</td><td>24</td> </tr> <tr> <td colspan="24" style="text-align: center;">Base</td> </tr> <tr> <td colspan="6" style="text-align: center;">Off-Peak</td> <td colspan="12" style="text-align: center;">Peak</td> <td colspan="6" style="text-align: center;">Off-Peak</td> </tr> <tr> <td colspan="6" style="text-align: center;">Overnight</td> <td colspan="18" style="text-align: center;">Extended Peak</td> </tr> <tr> <td colspan="6" style="background-color: #cccccc;"></td> <td colspan="12" style="text-align: center;">Weekend 3+4</td> <td colspan="4" style="text-align: center;">Weekend 5</td> <td colspan="6" style="text-align: center;">Weekend 6</td> </tr> </tbody> </table> <table border="1" style="margin-left: 40px;"> <thead> <tr> <th colspan="24" style="background-color: #ADD8E6;">Week</th> </tr> </thead> <tbody> <tr> <td>1</td><td>2</td><td>3</td><td>4</td><td>5</td><td>6</td><td>7</td><td>8</td><td>9</td><td>10</td><td>11</td><td>12</td><td>13</td><td>14</td><td>15</td><td>16</td><td>17</td><td>18</td><td>19</td><td>20</td><td>21</td><td>22</td><td>23</td><td>24</td> </tr> <tr> <td colspan="24" style="text-align: center;">Base (x7)</td> </tr> <tr> <td colspan="6" style="background-color: #cccccc;"></td> <td colspan="12" style="text-align: center;">Peak (x5)</td> <td colspan="6" style="background-color: #cccccc;"></td> </tr> </tbody> </table>		Daily																								1	2	3	4	5	6	7	8	9	10	11	12	13	14	15	16	17	18	19	20	21	22	23	24	Base																								Off-Peak						Peak												Off-Peak						Overnight						Extended Peak																		Block 1			Block 2			Block 3				Block 4				Block 5				Block 6												Block 3+4																		Weekend (x2)																								1	2	3	4	5	6	7	8	9	10	11	12	13	14	15	16	17	18	19	20	21	22	23	24	Base																								Off-Peak						Peak												Off-Peak						Overnight						Extended Peak																								Weekend 3+4												Weekend 5				Weekend 6						Week																								1	2	3	4	5	6	7	8	9	10	11	12	13	14	15	16	17	18	19	20	21	22	23	24	Base (x7)																														Peak (x5)																	
Daily																																																																																																																																																																																																																																																																																																																																																																																																																													
1	2	3	4	5	6	7	8	9	10	11	12	13	14	15	16	17	18	19	20	21	22	23	24																																																																																																																																																																																																																																																																																																																																																																																																						
Base																																																																																																																																																																																																																																																																																																																																																																																																																													
Off-Peak						Peak												Off-Peak																																																																																																																																																																																																																																																																																																																																																																																																											
Overnight						Extended Peak																																																																																																																																																																																																																																																																																																																																																																																																																							
Block 1			Block 2			Block 3				Block 4				Block 5				Block 6																																																																																																																																																																																																																																																																																																																																																																																																											
						Block 3+4																																																																																																																																																																																																																																																																																																																																																																																																																							
Weekend (x2)																																																																																																																																																																																																																																																																																																																																																																																																																													
1	2	3	4	5	6	7	8	9	10	11	12	13	14	15	16	17	18	19	20	21	22	23	24																																																																																																																																																																																																																																																																																																																																																																																																						
Base																																																																																																																																																																																																																																																																																																																																																																																																																													
Off-Peak						Peak												Off-Peak																																																																																																																																																																																																																																																																																																																																																																																																											
Overnight						Extended Peak																																																																																																																																																																																																																																																																																																																																																																																																																							
						Weekend 3+4												Weekend 5				Weekend 6																																																																																																																																																																																																																																																																																																																																																																																																							
Week																																																																																																																																																																																																																																																																																																																																																																																																																													
1	2	3	4	5	6	7	8	9	10	11	12	13	14	15	16	17	18	19	20	21	22	23	24																																																																																																																																																																																																																																																																																																																																																																																																						
Base (x7)																																																																																																																																																																																																																																																																																																																																																																																																																													
						Peak (x5)																																																																																																																																																																																																																																																																																																																																																																																																																							

Figure A8 N2EX United Kingdom Day Ahead Market Structure [16]

A.9 EXAA	Austria																																																																																																																																																			
<p>Bidding limitations</p> <table border="0"> <tr> <td style="vertical-align: top;"> <p><i>Price</i></p> <ul style="list-style-type: none"> • Minimum: 0 €/MWh • Maximum: €/MWh • Steps: 17 </td> <td style="vertical-align: top;"> <p><i>Volume</i></p> <ul style="list-style-type: none"> • Positive (purchase): decreasing with increasing prices • Negative (sell): increasing with decreasing prices • Positive and negative allowed in one bid: YES </td> </tr> </table>		<p><i>Price</i></p> <ul style="list-style-type: none"> • Minimum: 0 €/MWh • Maximum: €/MWh • Steps: 17 	<p><i>Volume</i></p> <ul style="list-style-type: none"> • Positive (purchase): decreasing with increasing prices • Negative (sell): increasing with decreasing prices • Positive and negative allowed in one bid: YES 																																																																																																																																																	
<p><i>Price</i></p> <ul style="list-style-type: none"> • Minimum: 0 €/MWh • Maximum: €/MWh • Steps: 17 	<p><i>Volume</i></p> <ul style="list-style-type: none"> • Positive (purchase): decreasing with increasing prices • Negative (sell): increasing with decreasing prices • Positive and negative allowed in one bid: YES 																																																																																																																																																			
<p>DAM Auction Trading: YES</p> <p>SINGLE BIDS</p> <ul style="list-style-type: none"> • Hourly Bid: YES (Stepwise, Linear Interpolation) • Price-independent Hourly Bid: YES <p>COMPLEX BIDS</p> <ul style="list-style-type: none"> • Flexible Hourly Bid: NO • Simple Block Bid (Execution type: "Partial", "Fill or Kill") <ul style="list-style-type: none"> k) User-defined: NO l) System-defined: daily (YES), weekend (NO), week (NO) <table border="1" style="margin-left: 40px;"> <thead> <tr style="background-color: #ADD8E6;"> <th colspan="24">Daily</th> </tr> </thead> <tbody> <tr> <td>1</td><td>2</td><td>3</td><td>4</td><td>5</td><td>6</td><td>7</td><td>8</td><td>9</td><td>10</td><td>11</td><td>12</td><td>13</td><td>14</td><td>15</td><td>16</td><td>17</td><td>18</td><td>19</td><td>20</td><td>21</td><td>22</td><td>23</td><td>24</td> </tr> <tr> <td colspan="24" style="text-align: center;">Base</td> </tr> <tr> <td colspan="6" style="text-align: center;">Off-Peak</td> <td colspan="12" style="text-align: center;">Peak</td> <td colspan="6" style="text-align: center;">Off-Peak</td> </tr> <tr> <td colspan="6" style="text-align: center;">Off 1</td> <td colspan="6" style="text-align: center;">Office</td> <td colspan="6" style="text-align: center;">Teatime</td> <td colspan="6" style="text-align: center;">Off 2</td> </tr> <tr> <td colspan="3" style="text-align: center;">Moonlight</td> <td colspan="3" style="text-align: center;">Sunrise</td> <td colspan="3" style="text-align: center;">Lunch</td> <td colspan="3" style="text-align: center;">LateT</td> <td colspan="3" style="text-align: center;">EarlyT</td> <td colspan="3" style="text-align: center;">Dream</td> <td colspan="3" style="text-align: center;">Awake</td> <td colspan="3" style="text-align: center;">EarlyT</td> <td colspan="3" style="text-align: center;">LateT</td> </tr> </tbody> </table> <ul style="list-style-type: none"> • Linked Block Bids: NO • Convertible Block Bid: NO 		Daily																								1	2	3	4	5	6	7	8	9	10	11	12	13	14	15	16	17	18	19	20	21	22	23	24	Base																								Off-Peak						Peak												Off-Peak						Off 1						Office						Teatime						Off 2						Moonlight			Sunrise			Lunch			LateT			EarlyT			Dream			Awake			EarlyT			LateT		
Daily																																																																																																																																																				
1	2	3	4	5	6	7	8	9	10	11	12	13	14	15	16	17	18	19	20	21	22	23	24																																																																																																																													
Base																																																																																																																																																				
Off-Peak						Peak												Off-Peak																																																																																																																																		
Off 1						Office						Teatime						Off 2																																																																																																																																		
Moonlight			Sunrise			Lunch			LateT			EarlyT			Dream			Awake			EarlyT			LateT																																																																																																																												
<p>DAM Continuous Trading: NO</p> <ul style="list-style-type: none"> • Simple Block Bid <ul style="list-style-type: none"> a) User-defined: NO b) System-defined: daily (NO), weekend (NO), week (NO) 																																																																																																																																																				

Figure A9 EXAA Austria Day Ahead Market Structure [16]

A.10 OTE	Czech Republic																																																																																																																																																
<p>Bidding limitations</p> <table border="0"> <tr> <td style="vertical-align: top;"> <p><i>Price</i></p> <ul style="list-style-type: none"> • Minimum: 0.01 €/MWh • Maximum: 4000 €/MWh • Steps: 25 </td> <td style="vertical-align: top;"> <p><i>Volume</i></p> <ul style="list-style-type: none"> • Positive (purchase): decreasing with increasing prices • Negative (sell): increasing with decreasing prices • Positive and negative allowed in one bid: YES </td> </tr> </table>		<p><i>Price</i></p> <ul style="list-style-type: none"> • Minimum: 0.01 €/MWh • Maximum: 4000 €/MWh • Steps: 25 	<p><i>Volume</i></p> <ul style="list-style-type: none"> • Positive (purchase): decreasing with increasing prices • Negative (sell): increasing with decreasing prices • Positive and negative allowed in one bid: YES 																																																																																																																																														
<p><i>Price</i></p> <ul style="list-style-type: none"> • Minimum: 0.01 €/MWh • Maximum: 4000 €/MWh • Steps: 25 	<p><i>Volume</i></p> <ul style="list-style-type: none"> • Positive (purchase): decreasing with increasing prices • Negative (sell): increasing with decreasing prices • Positive and negative allowed in one bid: YES 																																																																																																																																																
<p>DAM Auction Trading: YES</p> <p>SINGLE BIDS</p> <ul style="list-style-type: none"> • Hourly Bid: YES • Price-independent Hourly Bid: NO <p>COMPLEX BIDS</p> <ul style="list-style-type: none"> • Indivisible 1st step of hourly bids: YES • Flexible Hourly Bid: NO • Simple Block Bid (max 50 MW/h) <ul style="list-style-type: none"> m) User-defined: NO n) System-defined: daily (YES), weekend (NO), week (NO), business days (YES) <div style="text-align: center;"> <table border="1" style="margin: 0 auto;"> <tr style="background-color: #ADD8E6;"> <th colspan="24">Daily</th> </tr> <tr> <td>1</td><td>2</td><td>3</td><td>4</td><td>5</td><td>6</td><td>7</td><td>8</td><td>9</td><td>10</td><td>11</td><td>12</td><td>13</td><td>14</td><td>15</td><td>16</td><td>17</td><td>18</td><td>19</td><td>20</td><td>21</td><td>22</td><td>23</td><td>24</td> </tr> <tr style="background-color: #ADD8E6;"> <td colspan="24" style="text-align: center;">Base</td> </tr> </table> <table border="1" style="margin: 0 auto;"> <tr style="background-color: #ADD8E6;"> <th colspan="24">Business Days</th> </tr> <tr> <td>1</td><td>2</td><td>3</td><td>4</td><td>5</td><td>6</td><td>7</td><td>8</td><td>9</td><td>10</td><td>11</td><td>12</td><td>13</td><td>14</td><td>15</td><td>16</td><td>17</td><td>18</td><td>19</td><td>20</td><td>21</td><td>22</td><td>23</td><td>24</td> </tr> <tr> <td colspan="6" style="text-align: center;">Off-Peak</td> <td colspan="12" style="text-align: center;">Peak</td> <td colspan="6" style="text-align: center;">Off-Peak</td> </tr> </table> </div> <ul style="list-style-type: none"> • Linked Block Bids: NO • Convertible Block Bid: NO 		Daily																								1	2	3	4	5	6	7	8	9	10	11	12	13	14	15	16	17	18	19	20	21	22	23	24	Base																								Business Days																								1	2	3	4	5	6	7	8	9	10	11	12	13	14	15	16	17	18	19	20	21	22	23	24	Off-Peak						Peak												Off-Peak					
Daily																																																																																																																																																	
1	2	3	4	5	6	7	8	9	10	11	12	13	14	15	16	17	18	19	20	21	22	23	24																																																																																																																										
Base																																																																																																																																																	
Business Days																																																																																																																																																	
1	2	3	4	5	6	7	8	9	10	11	12	13	14	15	16	17	18	19	20	21	22	23	24																																																																																																																										
Off-Peak						Peak												Off-Peak																																																																																																																															
<p>DAM Continuous Trading: NO</p> <ul style="list-style-type: none"> • Simple Block Bid <ul style="list-style-type: none"> a) User-defined: NO b) System-defined: daily (NO), weekend (NO), week (NO) 																																																																																																																																																	

Figure A10 OTE Czech Republic Day Ahead Market Structure [16]

A.11 TGE	Poland																																																																																																
<p>Bidding limitations</p> <table border="0"> <tr> <td style="vertical-align: top;"><i>Price</i></td> <td style="vertical-align: top;"><i>Volume</i></td> </tr> <tr> <td> <ul style="list-style-type: none"> • Minimum: no limitation • Maximum: no limitation </td> <td></td> </tr> </table>		<i>Price</i>	<i>Volume</i>	<ul style="list-style-type: none"> • Minimum: no limitation • Maximum: no limitation 																																																																																													
<i>Price</i>	<i>Volume</i>																																																																																																
<ul style="list-style-type: none"> • Minimum: no limitation • Maximum: no limitation 																																																																																																	
<p>DAM Auction Trading: YES</p> <p>SINGLE BIDS</p> <ul style="list-style-type: none"> • Hourly Bid: YES • Price-independent Hourly Bid: YES <p>COMPLEX BIDS</p> <ul style="list-style-type: none"> • Flexible Hourly Bid: NO • Simple Block Bid <ul style="list-style-type: none"> o) User-defined: NO p) System-defined: daily (YES), weekend (NO), week (NO) <table border="1" data-bbox="518 1003 1385 1137" style="margin-left: auto; margin-right: auto;"> <tr style="background-color: #00FFFF;"> <td colspan="24" style="text-align: center;">Daily</td> </tr> <tr> <td>1</td><td>2</td><td>3</td><td>4</td><td>5</td><td>6</td><td>7</td><td>8</td><td>9</td><td>10</td><td>11</td><td>12</td><td>13</td><td>14</td><td>15</td><td>16</td><td>17</td><td>18</td><td>19</td><td>20</td><td>21</td><td>22</td><td>23</td><td>24</td> </tr> <tr> <td colspan="24" style="text-align: center;">Base</td> </tr> <tr> <td colspan="12" style="text-align: center;">Off-Peak</td> <td colspan="9" style="text-align: center;">Peak</td> <td colspan="3" style="text-align: center;">Off-P</td> </tr> </table> <ul style="list-style-type: none"> • Linked Block Bids: NO • Convertible Block Bid: NO 		Daily																								1	2	3	4	5	6	7	8	9	10	11	12	13	14	15	16	17	18	19	20	21	22	23	24	Base																								Off-Peak												Peak									Off-P		
Daily																																																																																																	
1	2	3	4	5	6	7	8	9	10	11	12	13	14	15	16	17	18	19	20	21	22	23	24																																																																										
Base																																																																																																	
Off-Peak												Peak									Off-P																																																																												
<p>DAM Continuous Trading: ???</p> <ul style="list-style-type: none"> • Simple Block Bid <ul style="list-style-type: none"> a) User-defined: NO b) System-defined: daily (NO), weekend (NO), week (NO) 																																																																																																	

Figure A11 TGE Poland Day Ahead Market Structure [16]

APPENDIX B

ARTIFICIAL NEURAL NETWORK (ANN)

Due to the non-linear structure of load amounts, other linear methods do not propose forecasting accurately. On the other hand, Artificial Neural Networks or Fuzzy Logic algorithms help to solve non-linear forecasting problem more accurately [14].

Working structure of ANN is based on human brain. Hence, ANN is designed in a way that how human brain learns. Human brain has billions of cells which are used to learn. These neurons are connected to each other. As Figure B1 shows, a neuron has four parts, i.e. soma, dendrite, axon and synapses.

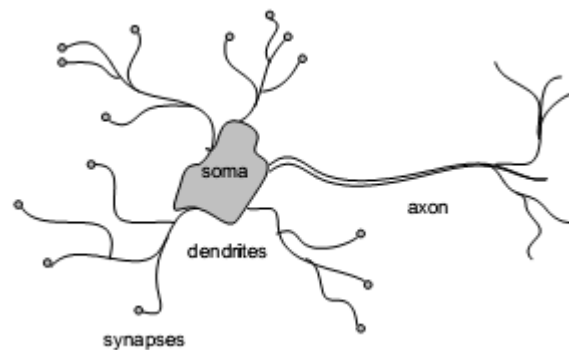

Figure B1 Illustration of Biological Neuron [14]

A neuron can be modeled as depicted in Figure B2.

Mathematical form of a neuron can be modeled as shown in Figure B2.

- Dendrites are input vector. They take information from different neuron.
- Synapses are weight vector. They put weight on input and send weighted input to soma.
- Soma is the adder of each weighted inputs. Hence, a transfer function occurs between input and added weighted inputs. Transfer function is threshold to fire up neuron.
- Axon is the resultant output vector.

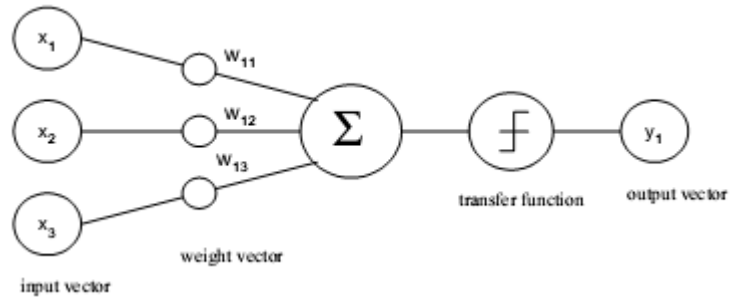

Figure B2 Mathematical Model of Biological Neuron [14]

Architecture, processing, and training are classifications of ANN. Architecture denote neural connections. Processing explains production of output for each and every input and weight according to the transfer function. Training is adoption of weight to each and every training data. [14]

ANN architecture has three parts. These are input layer, hidden layer and output layer. Dendrites forms input layer. Synapses, soma forms hidden layer and they process the information taken from dendrites. Axon is the output layer of network. Figure B3 depicts a general ANN model. [14]

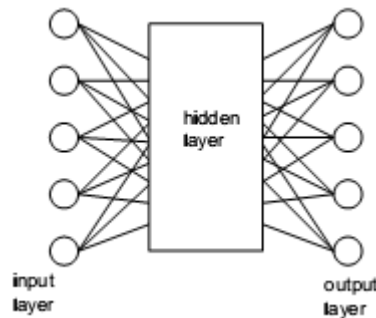

Figure B3 General ANN model [14]

Commonly used ANN architectures are a single layer network, a multi layer perceptron, Hopfield network, and Kohonen network.

The single-layer network has only input layer and output layer. Data is obtained and information flows in one direction, to the output. Thus, single layer network is feedforward type. The single-layer network is depicted in Figure B4.

The multi-layer perceptron is the architecture that is used in Short Term Load Forecasting. The multi-layer perceptron has input, hidden and output layers, as shown in Figure B4.

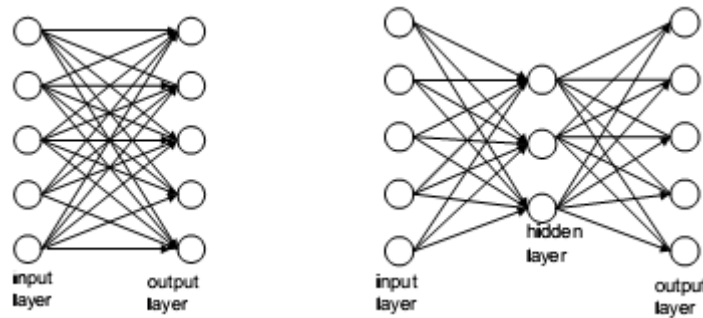

Figure B4 Single and Multi Layer Network [14]

B.1 Application of ANN to STLF

The feedforward multi-layered perceptron ANN architecture is the most commonly used method in applications of Short Term Load Forecasting. The output produced by this ANN is load value, including peak, valley, and mean daily load values. The ANN input is the prospective hour and day. However, additional data increase accuracy, such as giving temperature and humidity inputs to the network at learning process. [14]

Learning of network is based on supervised learning. In supervised learning, the network produces output based on the given inputs, such as load data, temperature, and humidity. Taken data is processed and it is compared with pre-tested outputs. If the output produced by the network is not accurate, the network changes weights of network so as to reach actual network. Hence, non linear relationship is learned by network and network can produce accurate results according to the historical data.

APPENDIX C

REAL DAY AHEAD MARKET DATA

C.1 Data for Chapter 7.1 and 7.2

Appendix C.1 includes the real data used in Chapter 7.1 and Chapter 7.2 simulations. Data is obtained by MFSC.

Table C1 Market bids for time interval 08:00-09:00

ID	SEVIYE	SAAT	TİP	LOT	MWh	FIYAT	SURE
5142102	1	8	S	0	0	0	1
5142102	2	8	S	0	0	2000	1
5142511	1	8	S	0	0	0	1
5142511	2	8	S	0	0	2000	1
5142857	1	8	S	-12	-1,2	0	1
5142857	2	8	S	-12	-1,2	2000	1
5143580	1	8	S	-20	-2	0	1
5143580	2	8	S	-20	-2	100	1
5143580	3	8	S	-20	-2	120	1
5143580	4	8	S	-20	-2	135	1
5143580	5	8	S	-20	-2	2000	1
5143978	1	8	S	-85	-8,5	0	1
5143978	2	8	S	-85	-8,5	2000	1
5145176	1	8	S	-8	-0,8	0	1
5145176	2	8	S	-8	-0,8	2000	1
5145944	1	8	S	1	0,1	0	1
5145944	2	8	S	1	0,1	2000	1
5150274	1	8	S	0	0	0	1
5150274	2	8	S	0	0	2000	1
5152780	1	8	S	103	10,3	0	1
5152780	2	8	S	103	10,3	500	1
5152780	3	8	S	0	0	500.01	1
5152780	4	8	S	0	0	2000	1
5152815	1	8	S	5000	500	0	1
5152815	2	8	S	199	19,9	0.99	1
5152815	3	8	S	199	19,9	2000	1
5152855	1	8	S	43	4,3	0	1
5152855	2	8	S	43	4,3	200	1
5152855	3	8	S	1	0,1	201	1

Table C2 Market bids for time interval 08:00-09:00 (continued)

5152855	4	8	S	0	0	2000	1
5152927	1	8	S	5905	590,5	0	1
5152927	2	8	S	5905	590,5	180	1
5152927	3	8	S	5905	590,5	180.01	1
5152927	4	8	S	0	0	250	1
5152927	5	8	S	0	0	250.01	1
5152927	6	8	S	0	0	2000	1
5153187	1	8	S	7	0,7	0	1
5153187	2	8	S	7	0,7	2000	1
5153547	1	8	S	10	1	0	1
5153547	2	8	S	10	1	234.99	1
5153547	3	8	S	10	1	2000	1
5154521	1	8	S	0	0	0	1
5154521	2	8	S	0	0	186.86	1
5154521	3	8	S	-193	-19,3	186.87	1
5154521	4	8	S	-193	-19,3	2000	1
5155713	1	8	S	-1510	-151	0	1
5155713	2	8	S	-1510	-151	75	1
5155713	3	8	S	-2510	-251	75.01	1
5155713	4	8	S	-2510	-251	89.99	1
5155713	5	8	S	-2510	-251	90	1
5155713	6	8	S	-2510	-251	99.99	1
5155713	7	8	S	-3575	-357,5	100	1
5155713	8	8	S	-3575	-357,5	109.99	1
5155713	9	8	S	-3575	-357,5	110	1
5155713	10	8	S	-3575	-357,5	119.99	1
5155713	11	8	S	-3965	-396,5	120	1
5155713	12	8	S	-3965	-396,5	129.99	1
5155713	13	8	S	-4065	-406,5	130	1
5155713	14	8	S	-4065	-406,5	139.99	1
5155713	15	8	S	-4065	-406,5	140	1
5155713	16	8	S	-4065	-406,5	2000	1
5155820	1	8	S	8	0,8	0	1
5155820	2	8	S	8	0,8	2000	1
5160382	1	8	S	0	0	0	1
5160382	2	8	S	0	0	193.98	1
5160382	3	8	S	-47	-4,7	193.99	1
5160382	4	8	S	-47	-4,7	398.99	1
5160382	5	8	S	-50	-5	399	1
5160382	6	8	S	-50	-5	1990	1
5160382	7	8	S	-100	-10	1990.01	1

Table C3 Market bids for time interval 08:00-09:00 (continued)

5160382	8	8	S	-100	-10	2000	1
5160433	1	8	S	15	1,5	0	1
5160433	2	8	S	15	1,5	2000	1
5160803	1	8	S	0	0	0	1
5160803	2	8	S	0	0	2000	1
5161271	1	8	S	0	0	0	1
5161271	2	8	S	-200	-20	175	1
5161271	3	8	S	-450	-45	195	1
5161271	4	8	S	-450	-45	195.01	1
5161271	5	8	S	-450	-45	195.02	1
5161271	6	8	S	-450	-45	199.99	1
5161271	7	8	S	-550	-55	200	1
5161271	8	8	S	-550	-55	204.99	1
5161271	9	8	S	-550	-55	205	1
5161271	10	8	S	-550	-55	205.01	1
5161271	11	8	S	-1200	-120	2000	1
5161719	1	8	S	-10	-1	0	1
5161719	2	8	S	-10	-1	2000	1
5164316	1	8	S	-45	-4,5	0	1
5164316	2	8	S	-45	-4,5	2000	1
5164543	1	8	S	101	10,1	0	1
5164543	2	8	S	101	10,1	2000	1
5164632	1	8	S	2500	250	0	1
5164632	2	8	S	2500	250	120	1
5164632	3	8	S	2500	250	120.01	1
5164632	4	8	S	2500	250	140	1
5164632	5	8	S	2500	250	140.01	1
5164632	6	8	S	2500	250	160	1
5164632	7	8	S	2500	250	160.01	1
5164632	8	8	S	2500	250	180	1
5164632	9	8	S	1875	187,5	180.01	1
5164632	10	8	S	1875	187,5	200	1
5164632	11	8	S	0	0	200.01	1
5164632	12	8	S	0	0	225	1
5164632	13	8	S	0	0	2000	1
5164725	1	8	S	30	3	0	1
5164725	2	8	S	20	2	140	1
5164725	3	8	S	20	2	165	1
5164725	4	8	S	0	0	175	1
5164725	5	8	S	0	0	180	1
5164725	6	8	S	-30	-3	185	1

Table C4 Market bids for time interval 08:00-09:00 (continued)

5164725	7	8	S	-35	-3,5	200	1
5164725	8	8	S	-50	-5	2000	1
5164913	1	8	S	120	12	0	1
5164913	2	8	S	120	12	139.98	1
5164913	3	8	S	0	0	139.99	1
5164913	4	8	S	0	0	187.63	1
5164913	5	8	S	-300	-30	187.64	1
5164913	6	8	S	-300	-30	2000	1
5165247	1	8	S	-136	-13,6	0	1
5165247	2	8	S	-136	-13,6	2000	1
5165355	1	8	S	0	0	0	1
5165355	2	8	S	0	0	2000	1
5165412	1	8	S	0	0	0	1
5165412	2	8	S	0	0	189.86	1
5165412	3	8	S	-183	-18,3	189.87	1
5165412	4	8	S	-183	-18,3	2000	1
5165730	1	8	S	8	0,8	0	1
5165730	2	8	S	8	0,8	2000	1
5166318	1	8	S	12	1,2	0	1
5166318	2	8	S	12	1,2	2000	1
5167415	1	8	S	10	1	0	1
5167415	2	8	S	10	1	2000	1
5167550	1	8	S	-5	-0,5	0	1
5167550	2	8	S	-5	-0,5	2000	1
5169030	1	8	S	10	1	0	1
5169030	2	8	S	10	1	634.99	1
5169030	3	8	S	-300	-30	635	1
5169030	4	8	S	-300	-30	654.99	1
5169030	5	8	S	-650	-65	655	1
5169030	6	8	S	-650	-65	2000	1
5169663	1	8	S	-284	-28,4	0	1
5169663	2	8	S	-284	-28,4	2000	1
5170003	1	8	S	-19	-1,9	0	1
5170003	2	8	S	-19	-1,9	2000	1
5170248	1	8	S	28	2,8	0	1
5170248	2	8	S	28	2,8	2000	1
5170454	1	8	S	92	9,2	0	1
5170454	2	8	S	92	9,2	2000	1
5171772	1	8	S	-2	-0,2	0	1
5171772	2	8	S	-2	-0,2	2000	1
5173063	1	8	S	12	1,2	0	1

Table C5 Market bids for time interval 08:00-09:00 (continued)

5173063	2	8	S	12	1,2	2000	1
5173394	1	8	S	0	0	0	1
5173394	2	8	S	0	0	250.98	1
5173394	3	8	S	-70	-7	250.99	1
5173394	4	8	S	-70	-7	2000	1
5174407	1	8	S	-1	-0,1	0	1
5174407	2	8	S	-1	-0,1	2000	1
5178498	1	8	S	0	0	0	1
5178498	2	8	S	0	0	164.59	1
5178498	3	8	S	-22	-2,2	164.6	1
5178498	4	8	S	-22	-2,2	175	1
5178498	5	8	S	-22	-2,2	500	1
5178498	6	8	S	-22	-2,2	2000	1
5178728	1	8	S	0	0	0	1
5178728	2	8	S	0	0	639	1
5178728	3	8	S	-240	-24	640	1
5178728	4	8	S	-240	-24	2000	1
5179219	1	8	S	0	0	0	1
5179219	2	8	S	0	0	639	1
5179219	3	8	S	-300	-30	640	1
5179219	4	8	S	-300	-30	2000	1
5179399	1	8	S	4	0,4	0	1
5179399	2	8	S	4	0,4	2000	1
5180264	1	8	S	-35	-3,5	0	1
5180264	2	8	S	-35	-3,5	2000	1
5180454	1	8	S	0	0	0	1
5180454	2	8	S	0	0	2000	1
5180700	1	8	S	494	49,4	0	1
5180700	2	8	S	494	49,4	200	1
5180700	3	8	S	0	0	250	1
5180700	4	8	S	0	0	2000	1
5180727	1	8	S	-116	-11,6	0	1
5180727	2	8	S	-116	-11,6	2000	1
5181130	1	8	S	-816	-81,6	0	1
5181130	2	8	S	-816	-81,6	2000	1
5181236	1	8	S	14	1,4	0	1
5181236	2	8	S	14	1,4	2000	1
5181481	1	8	S	3	0,3	0	1
5181481	2	8	S	3	0,3	200	1
5181481	3	8	S	0	0	200.01	1
5181481	4	8	S	0	0	2000	1

Table C6 Market bids for time interval 08:00-09:00 (continued)

5182048	1	8	S	-33	-3,3	0	1
5182048	2	8	S	-33	-3,3	2000	1
5182354	1	8	S	0	0	0	1
5182354	2	8	S	0	0	300	1
5182354	3	8	S	0	0	2000	1
5182555	1	8	S	-9	-0,9	0	1
5182555	2	8	S	-9	-0,9	2000	1
5182614	1	8	S	31	3,1	0	1
5182614	2	8	S	31	3,1	2000	1
5183792	1	8	S	-6	-0,6	0	1
5183792	2	8	S	-6	-0,6	2000	1
5184069	1	8	S	59	5,9	0	1
5184069	2	8	S	58	5,8	90	1
5184069	3	8	S	57	5,7	110	1
5184069	4	8	S	56	5,6	120	1
5184069	5	8	S	55	5,5	155	1
5184069	6	8	S	0	0	2000	1
5185244	1	8	S	-6	-0,6	0	1
5185244	2	8	S	-6	-0,6	2000	1
5186304	1	8	S	0	0	0	1
5186304	2	8	S	0	0	149	1
5186304	3	8	S	-2	-0,2	150	1
5186304	4	8	S	-2	-0,2	2000	1
5190667	1	8	S	7	0,7	0	1
5190667	2	8	S	7	0,7	100	1
5190667	3	8	S	7	0,7	100.01	1
5190667	4	8	S	7	0,7	2000	1
5191112	1	8	S	0	0	0	1
5191112	2	8	S	0	0	2000	1
5191209	1	8	S	2500	250	0	1
5191209	2	8	S	2500	250	150	1
5191209	3	8	S	2500	250	151	1
5191209	4	8	S	2500	250	200	1
5191209	5	8	S	2500	250	200.01	1
5191209	6	8	S	2500	250	250	1
5191209	7	8	S	1250	125	250.01	1
5191209	8	8	S	1250	125	300	1
5191209	9	8	S	0	0	300.01	1
5191209	10	8	S	0	0	320	1
5191209	11	8	S	0	0	320.01	1
5191209	12	8	S	0	0	400	1

Table C7 Market bids for time interval 08:00-09:00 (continued)

5191209	13	8	S	0	0	400.01	1
5191209	14	8	S	0	0	2000	1
5191380	1	8	S	0	0	0	1
5191380	2	8	S	0	0	2000	1
5191471	1	8	S	9	0,9	0	1
5191471	2	8	S	0	0	2000	1
5192619	1	8	S	2	0,2	0	1
5192619	2	8	S	2	0,2	214.93	1
5192619	3	8	S	-170	-17	214.94	1
5192619	4	8	S	-170	-17	2000	1
5192793	1	8	S	0	0	0	1
5192793	2	8	S	0	0	2000	1
5192964	1	8	S	0	0	0	1
5192964	2	8	S	0	0	185	1
5192964	3	8	S	-485	-48,5	185.01	1
5192964	4	8	S	-485	-48,5	250	1
5192964	5	8	S	-485	-48,5	250.01	1
5192964	6	8	S	-485	-48,5	2000	1
5197512	1	8	S	3	0,3	0	1
5197512	2	8	S	3	0,3	50	1
5197512	3	8	S	2	0,2	50.1	1
5197512	4	8	S	2	0,2	100	1
5197512	5	8	S	2	0,2	100.1	1
5197512	6	8	S	2	0,2	125	1
5197512	7	8	S	2	0,2	125.1	1
5197512	8	8	S	2	0,2	150	1
5197512	9	8	S	2	0,2	150.1	1
5197512	10	8	S	2	0,2	175	1
5197512	11	8	S	2	0,2	175.1	1
5197512	12	8	S	2	0,2	185	1
5197512	13	8	S	2	0,2	185.1	1
5197512	14	8	S	2	0,2	197.1	1
5197512	15	8	S	2	0,2	197.2	1
5197512	16	8	S	1	0,1	205	1
5197512	17	8	S	1	0,1	214.1	1
5197512	18	8	S	0	0	215	1
5197512	19	8	S	0	0	2000	1
5197663	1	8	S	100	10	0	1
5197663	2	8	S	100	10	2000	1
5197730	1	8	S	12	1,2	0	1
5197730	2	8	S	12	1,2	130	1

Table C8 Market bids for time interval 08:00-09:00 (continued)

5197730	3	8	S	12	1,2	140	1
5197730	4	8	S	12	1,2	145	1
5197730	5	8	S	12	1,2	150	1
5197730	6	8	S	12	1,2	155	1
5197730	7	8	S	12	1,2	160	1
5197730	8	8	S	12	1,2	165	1
5197730	9	8	S	12	1,2	170	1
5197730	10	8	S	12	1,2	175	1
5197730	11	8	S	12	1,2	180	1
5197730	12	8	S	12	1,2	185	1
5197730	13	8	S	12	1,2	190	1
5197730	14	8	S	12	1,2	195	1
5197730	15	8	S	12	1,2	200	1
5197730	16	8	S	12	1,2	205	1
5197730	17	8	S	12	1,2	210	1
5197730	18	8	S	12	1,2	220	1
5197730	19	8	S	12	1,2	250	1
5197730	20	8	S	12	1,2	350	1
5197730	21	8	S	12	1,2	500	1
5197730	22	8	S	12	1,2	750	1
5197730	23	8	S	12	1,2	1000	1
5197730	24	8	S	12	1,2	1250	1
5197730	25	8	S	12	1,2	1500	1
5197730	26	8	S	12	1,2	1750	1
5197730	27	8	S	12	1,2	2000	1
5197763	1	8	S	557	55,7	0	1
5197763	2	8	S	557	55,7	100	1
5197763	3	8	S	557	55,7	125	1
5197763	4	8	S	557	55,7	150	1
5197763	5	8	S	557	55,7	175	1
5197763	6	8	S	557	55,7	200	1
5197763	7	8	S	557	55,7	225	1
5197763	8	8	S	557	55,7	250	1
5197763	9	8	S	557	55,7	275	1
5197763	10	8	S	557	55,7	300	1
5197763	11	8	S	557	55,7	325	1
5197763	12	8	S	557	55,7	350	1
5197763	13	8	S	557	55,7	375	1
5197763	14	8	S	557	55,7	400	1
5197763	15	8	S	557	55,7	425	1
5197763	16	8	S	557	55,7	450	1

Table C9 Market bids for time interval 08:00-09:00 (continued)

5197763	17	8	S	557	55,7	475	1
5197763	18	8	S	557	55,7	500	1
5197763	19	8	S	0	0	500.01	1
5197763	20	8	S	0	0	2000	1
5197791	1	8	S	1	0,1	0	1
5197791	2	8	S	1	0,1	200.02	1
5197791	3	8	S	0	0	200.03	1
5197791	4	8	S	0	0	2000	1
5198011	1	8	S	-103	-10,3	0	1
5198011	2	8	S	-103	-10,3	2000	1
5198068	1	8	S	-18	-1,8	0	1
5198068	2	8	S	-18	-1,8	70	1
5198068	3	8	S	-28	-2,8	70.01	1
5198068	4	8	S	-28	-2,8	200	1
5198068	5	8	S	-38	-3,8	200.01	1
5198068	6	8	S	-38	-3,8	2000	1
5198244	1	8	S	0	0	0	1
5198244	2	8	S	0	0	2000	1
5198324	1	8	S	35	3,5	0	1
5198324	2	8	S	35	3,5	210	1
5198324	3	8	S	-35	-3,5	211	1
5198324	4	8	S	-35	-3,5	700	1
5198324	5	8	S	-35	-3,5	701	1
5198324	6	8	S	-35	-3,5	2000	1
5198467	1	8	S	-7	-0,7	0	1
5198467	2	8	S	-7	-0,7	2000	1
5198540	1	8	S	0	0	0	1
5198540	2	8	S	0	0	49.98	1
5198540	3	8	S	-4	-0,4	49.99	1
5198540	4	8	S	-4	-0,4	50	1
5198540	5	8	S	-4	-0,4	2000	1
5198571	1	8	S	-10	-1	0	1
5198571	2	8	S	-10	-1	2000	1
5198649	1	8	S	0	0	0	1
5198649	2	8	S	0	0	2000	1
5198668	1	8	S	-6	-0,6	0	1
5198668	2	8	S	-6	-0,6	2000	1
5198775	1	8	S	-4	-0,4	0	1
5198775	2	8	S	-4	-0,4	2000	1
5198796	1	8	S	-4	-0,4	0	1
5198796	2	8	S	-4	-0,4	2000	1

Table C10 Market bids for time interval 08:00-09:00 (continued)

5198817	1	8	S	49	4,9	0	1
5198817	2	8	S	49	4,9	89.9	1
5198817	3	8	S	49	4,9	90	1
5198817	4	8	S	49	4,9	129.9	1
5198817	5	8	S	35	3,5	130	1
5198817	6	8	S	35	3,5	174.9	1
5198817	7	8	S	35	3,5	175	1
5198817	8	8	S	35	3,5	270	1
5198817	9	8	S	0	0	350	1
5198817	10	8	S	0	0	2000	1
5198846	1	8	S	-30	-3	0	1
5198846	2	8	S	-30	-3	2000	1
5198878	1	8	S	-15	-1,5	0	1
5198878	2	8	S	-15	-1,5	2000	1
5198980	1	8	S	-30	-3	0	1
5198980	2	8	S	-30	-3	2000	1
5199004	1	8	S	0	0	0	1
5199004	2	8	S	0	0	98.99	1
5199004	3	8	S	-50	-5	99	1
5199004	4	8	S	-50	-5	2000	1
5199133	1	8	S	26	2,6	0	1
5199133	2	8	S	26	2,6	2000	1
5199159	1	8	S	27	2,7	0	1
5199159	2	8	S	27	2,7	2000	1
5199170	1	8	S	0	0	0	1
5199170	2	8	S	0	0	2000	1
5199625	1	8	S	990	99	0	1
5199625	2	8	S	990	99	2000	1
5199652	1	8	S	950	95	0	1
5199652	2	8	S	950	95	196	1
5199652	3	8	S	0	0	196.01	1
5199652	4	8	S	0	0	206	1
5199652	5	8	S	0	0	206.01	1
5199652	6	8	S	0	0	216	1
5199652	7	8	S	0	0	216.01	1
5199652	8	8	S	0	0	226	1
5199652	9	8	S	0	0	226.01	1
5199652	10	8	S	0	0	2000	1
5199680	1	8	S	0	0	0	1
5199680	2	8	S	0	0	209.37	1
5199680	3	8	S	-669	-66,9	209.38	1

Table C11 Market bids for time interval 08:00-09:00 (continued)

5199680	4	8	S	-669	-66,9	299.37	1
5199680	5	8	S	-1891	-189,1	299.38	1
5199680	6	8	S	-1891	-189,1	2000	1
5199773	1	8	S	0	0	0	1
5199773	2	8	S	0	0	2000	1
5199853	1	8	S	0	0	0	1
5199853	2	8	S	0	0	209.41	1
5199853	3	8	S	-233	-23,3	209.42	1
5199853	4	8	S	-233	-23,3	299.41	1
5199853	5	8	S	-698	-69,8	299.42	1
5199853	6	8	S	-698	-69,8	2000	1
5199896	1	8	S	33	3,3	0	1
5199896	2	8	S	33	3,3	100	1
5199896	3	8	S	33	3,3	110	1
5199896	4	8	S	33	3,3	120	1
5199896	5	8	S	33	3,3	125	1
5199896	6	8	S	33	3,3	130	1
5199896	7	8	S	33	3,3	135	1
5199896	8	8	S	33	3,3	140	1
5199896	9	8	S	33	3,3	145	1
5199896	10	8	S	33	3,3	150	1
5199896	11	8	S	33	3,3	155	1
5199896	12	8	S	33	3,3	160	1
5199896	13	8	S	33	3,3	165	1
5199896	14	8	S	33	3,3	170	1
5199896	15	8	S	0	0	175	1
5199896	16	8	S	0	0	180	1
5199896	17	8	S	0	0	185	1
5199896	18	8	S	0	0	190	1
5199896	19	8	S	0	0	200	1
5199896	20	8	S	0	0	201	1
5199896	21	8	S	0	0	2000	1
5199945	1	8	S	339	33,9	0	1
5199945	2	8	S	339	33,9	2000	1
5199978	1	8	S	0	0	0	1
5199978	2	8	S	0	0	999	1
5199978	3	8	S	0	0	999.01	1
5199978	4	8	S	0	0	2000	1
5200004	1	8	S	-30	-3	0	1
5200004	2	8	S	-30	-3	2000	1
5200086	1	8	S	299	29,9	0	1

Table C12 Market bids for time interval 08:00-09:00 (continued)

5200086	2	8	S	299	29,9	2000	1
5200108	1	8	S	8	0,8	0	1
5200108	2	8	S	8	0,8	100	1
5200108	3	8	S	-67	-6,7	100.01	1
5200108	4	8	S	-67	-6,7	2000	1
5200148	1	8	S	1657	165,7	0	1
5200148	2	8	S	1657	165,7	200	1
5200148	3	8	S	0	0	200.1	1
5200148	4	8	S	0	0	250	1
5200148	5	8	S	0	0	250.1	1
5200148	6	8	S	0	0	300	1
5200148	7	8	S	0	0	300.1	1
5200148	8	8	S	0	0	2000	1
5200243	1	8	S	-170	-17	0	1
5200243	2	8	S	-170	-17	209.99	1
5200243	3	8	S	-440	-44	210	1
5200243	4	8	S	-440	-44	2000	1
5200292	1	8	S	0	0	0	1
5200292	2	8	S	0	0	2000	1
5200383	1	8	S	150	15	0	1
5200383	2	8	S	150	15	500	1
5200383	3	8	S	0	0	501	1
5200383	4	8	S	0	0	2000	1
5200420	1	8	S	0	0	0	1
5200420	2	8	S	0	0	155.27	1
5200420	3	8	S	0	0	170.8	1
5200420	4	8	S	0	0	2000	1
5200593	1	8	S	0	0	0	1
5200593	2	8	S	0	0	2000	1
5200606	1	8	S	0	0	0	1
5200606	2	8	S	0	0	75	1
5200606	3	8	S	-10	-1	75.99	1
5200606	4	8	S	-11	-1,1	89.99	1
5200606	5	8	S	-12	-1,2	169.91	1
5200606	6	8	S	-14	-1,4	200.01	1
5200606	7	8	S	-20	-2	2000	1
5200750	1	8	S	-37	-3,7	0	1
5200750	2	8	S	-37	-3,7	2000	1
5200794	1	8	S	0	0	0	1
5200794	2	8	S	0	0	144.99	1
5200794	3	8	S	0	0	145	1

Table C13 Market bids for time interval 08:00-09:00 (continued)

5200794	4	8	S	0	0	2000	1
5200902	1	8	S	0	0	0	1
5200902	2	8	S	0	0	2000	1
5200923	1	8	S	-22	-2,2	0	1
5200923	2	8	S	-22	-2,2	2000	1
5200977	1	8	S	18	1,8	0	1
5200977	2	8	S	18	1,8	2000	1
5200985	1	8	S	-34	-3,4	0	1
5200985	2	8	S	-34	-3,4	2000	1
5201032	1	8	S	4670	467	0	1
5201032	2	8	S	4670	467	91	1
5201032	3	8	S	4458	445,8	91.01	1
5201032	4	8	S	4458	445,8	109.99	1
5201032	5	8	S	4168	416,8	110	1
5201032	6	8	S	4168	416,8	119.99	1
5201032	7	8	S	4028	402,8	120	1
5201032	8	8	S	4028	402,8	129.99	1
5201032	9	8	S	3878	387,8	130	1
5201032	10	8	S	3878	387,8	139.99	1
5201032	11	8	S	3818	381,8	140	1
5201032	12	8	S	3818	381,8	2000	1
5201107	1	8	S	-144	-14,4	0	1
5201107	2	8	S	-144	-14,4	2000	1
5201174	1	8	S	-18	-1,8	0	1
5201174	2	8	S	-18	-1,8	2000	1
5201176	1	8	S	0	0	0	1
5201176	2	8	S	0	0	145	1
5201176	3	8	S	-20	-2	145.01	1
5201176	4	8	S	-20	-2	2000	1
5201213	1	8	S	787	78,7	0	1
5201213	2	8	S	787	78,7	2000	1
5201245	1	8	S	13	1,3	0	1
5201245	2	8	S	13	1,3	2000	1
5201352	1	8	S	-9	-0,9	0	1
5201352	2	8	S	-9	-0,9	2000	1
5201408	1	8	S	600	60	0	1
5201408	2	8	S	600	60	2000	1
5201438	1	8	S	-20	-2	0	1
5201438	2	8	S	-20	-2	2000	1
5201472	1	8	S	61	6,1	0	1
5201472	2	8	S	61	6,1	2000	1

Table C14 Market bids for time interval 08:00-09:00 (continued)

5201502	1	8	S	3	0,3	0	1
5201502	2	8	S	3	0,3	172.98	1
5201502	3	8	S	3	0,3	172.99	1
5201502	4	8	S	3	0,3	176.98	1
5201502	5	8	S	3	0,3	176.99	1
5201502	6	8	S	3	0,3	182.98	1
5201502	7	8	S	-197	-19,7	182.99	1
5201502	8	8	S	-197	-19,7	188.98	1
5201502	9	8	S	-197	-19,7	188.99	1
5201502	10	8	S	-197	-19,7	197.98	1
5201502	11	8	S	-197	-19,7	197.99	1
5201502	12	8	S	-197	-19,7	221.98	1
5201502	13	8	S	-197	-19,7	221.99	1
5201502	14	8	S	-197	-19,7	2000	1
5201537	1	8	S	-10	-1	0	1
5201537	2	8	S	-10	-1	2000	1
5201558	1	8	S	0	0	0	1
5201558	2	8	S	0	0	84.99	1
5201558	3	8	S	0	0	85	1
5201558	4	8	S	0	0	109.99	1
5201558	5	8	S	0	0	110	1
5201558	6	8	S	0	0	124.99	1
5201558	7	8	S	0	0	125	1
5201558	8	8	S	0	0	144.99	1
5201558	9	8	S	0	0	145	1
5201558	10	8	S	0	0	2000	1
5201607	1	8	S	-438	-43,8	0	1
5201607	2	8	S	-438	-43,8	2000	1
5201614	1	8	S	-6	-0,6	0	1
5201614	2	8	S	-6	-0,6	2000	1
5201665	1	8	S	-13	-1,3	0	1
5201665	2	8	S	-13	-1,3	2000	1
5201696	1	8	S	-3170	-317	0	1
5201696	2	8	S	-3170	-317	2000	1
5201751	1	8	S	-16	-1,6	0	1
5201751	2	8	S	-16	-1,6	2000	1
5201857	1	8	S	0	0	0	1
5201857	2	8	S	0	0	84.99	1
5201857	3	8	S	0	0	85	1
5201857	4	8	S	0	0	109.99	1
5201857	5	8	S	-40	-4	110	1

Table C15 Market bids for time interval 08:00-09:00 (continued)

5201857	6	8	S	-40	-4	124.99	1
5201857	7	8	S	-40	-4	125	1
5201857	8	8	S	-40	-4	144.99	1
5201857	9	8	S	-40	-4	145	1
5201857	10	8	S	-40	-4	2000	1
5201981	1	8	S	290	29	0	1
5201981	2	8	S	290	29	2000	1
5202025	1	8	S	10	1	0	1
5202025	2	8	S	10	1	120	1
5202025	3	8	S	0	0	170	1
5202025	4	8	S	0	0	2000	1
5202080	1	8	S	0	0	0	1
5202080	2	8	S	0	0	74.99	1
5202080	3	8	S	0	0	75	1
5202080	4	8	S	0	0	104.99	1
5202080	5	8	S	0	0	105	1
5202080	6	8	S	0	0	124.99	1
5202080	7	8	S	0	0	125	1
5202080	8	8	S	0	0	2000	1
5202210	1	8	S	-110	-11	0	1
5202210	2	8	S	-110	-11	144.99	1
5202210	3	8	S	-1250	-125	145	1
5202210	4	8	S	-1250	-125	169.99	1
5202210	5	8	S	-1250	-125	170	1
5202210	6	8	S	-1250	-125	194.99	1
5202210	7	8	S	-1250	-125	195	1
5202210	8	8	S	-1250	-125	2000	1
5202226	1	8	S	18	1,8	0	1
5202226	2	8	S	18	1,8	2000	1
5202263	1	8	S	61	6,1	0	1
5202263	2	8	S	60	6	75	1
5202263	3	8	S	59	5,9	99	1
5202263	4	8	S	59	5,9	129	1
5202263	5	8	S	58	5,8	149	1
5202263	6	8	S	58	5,8	159	1
5202263	7	8	S	58	5,8	2000	1
5202404	1	8	S	-10	-1	0	1
5202404	2	8	S	-10	-1	2000	1
5202676	1	8	S	-190	-19	0	1
5202676	2	8	S	-190	-19	2000	1
5202716	1	8	S	52	5,2	0	1

Table C16 Market bids for time interval 08:00-09:00 (continued)

5202716	2	8	S	52	5,2	2000	1
5202789	1	8	S	3265	326,5	0	1
5202789	2	8	S	3265	326,5	2000	1
5202795	1	8	S	32	3,2	0	1
5202795	2	8	S	32	3,2	185.98	1
5202795	3	8	S	-40	-4	185.99	1
5202795	4	8	S	-40	-4	204.98	1
5202795	5	8	S	-246	-24,6	204.99	1
5202795	6	8	S	-246	-24,6	2000	1
5202843	1	8	S	0	0	0	1
5202843	2	8	S	0	0	139.99	1
5202843	3	8	S	0	0	140	1
5202843	4	8	S	0	0	149.99	1
5202843	5	8	S	0	0	150	1
5202843	6	8	S	0	0	179.99	1
5202843	7	8	S	0	0	180	1
5202843	8	8	S	0	0	2000	1
5202895	1	8	S	21	2,1	0	1
5202895	2	8	S	21	2,1	2000	1
5202926	1	8	S	-3	-0,3	0	1
5202926	2	8	S	-3	-0,3	2000	1
5203032	1	8	S	0	0	0	1
5203032	2	8	S	0	0	184.99	1
5203032	3	8	S	0	0	185	1
5203032	4	8	S	0	0	2000	1
5203048	1	8	S	41	4,1	0	1
5203048	2	8	S	41	4,1	2000	1
5203296	1	8	S	-45	-4,5	0	1
5203296	2	8	S	-45	-4,5	2000	1
5203317	1	8	S	-30	-3	0	1
5203317	2	8	S	-30	-3	2000	1
5203340	1	8	S	212	21,2	0	1
5203340	2	8	S	212	21,2	180	1
5203340	3	8	S	200	20	400	1
5203340	4	8	S	150	15	500	1
5203340	5	8	S	100	10	550	1
5203340	6	8	S	0	0	2000	1
5203413	1	8	S	4	0,4	0	1
5203413	2	8	S	2	0,2	140	1
5203413	3	8	S	0	0	155	1
5203413	4	8	S	-40	-4	180	1

Table C17 Market bids for time interval 08:00-09:00 (continued)

5203413	5	8	S	-40	-4	2000	1
5203462	1	8	S	13	1,3	0	1
5203462	2	8	S	13	1,3	2000	1
5203550	1	8	S	6948	694,8	0	1
5203550	2	8	S	6948	694,8	160	1
5203550	3	8	S	6748	674,8	193	1
5203550	4	8	S	5748	574,8	240	1
5203550	5	8	S	0	0	250	1
5203550	6	8	S	0	0	500	1
5203550	7	8	S	0	0	2000	1
5203615	1	8	S	0	0	0	1
5203615	2	8	S	0	0	299.99	1
5203615	3	8	S	-200	-20	300	1
5203615	4	8	S	-200	-20	2000	1
5203616	1	8	S	100	10	0	1
5203616	2	8	S	100	10	2000	1
5203645	1	8	S	0	0	0	1
5203645	2	8	S	0	0	155.68	1
5203645	3	8	S	-170	-17	155.69	1
5203645	4	8	S	-170	-17	2000	1
5203720	1	8	S	-379	-37,9	0	1
5203720	2	8	S	-379	-37,9	2000	1
5203757	1	8	S	-38	-3,8	0	1
5203757	2	8	S	-38	-3,8	2000	1
5203767	1	8	S	-148	-14,8	0	1
5203767	2	8	S	-148	-14,8	2000	1
5203854	1	8	S	-225	-22,5	0	1
5203854	2	8	S	-225	-22,5	2000	1
5203930	1	8	S	-13	-1,3	0	1
5203930	2	8	S	-13	-1,3	2000	1
5203947	1	8	S	3	0,3	0	1
5203947	2	8	S	3	0,3	209.99	1
5203947	3	8	S	-1379	-137,9	210	1
5203947	4	8	S	-1379	-137,9	2000	1
5203977	1	8	S	-91	-9,1	0	1
5203977	2	8	S	-91	-9,1	2000	1
5204033	1	8	S	-20	-2	0	1
5204033	2	8	S	-20	-2	2000	1
5204048	1	8	S	0	0	0	1
5204048	2	8	S	0	0	29.98	1
5204048	3	8	S	-15	-1,5	29.99	1

Table C18 Market bids for time interval 08:00-09:00 (continued)

5204048	4	8	S	-15	-1,5	119.98	1
5204048	5	8	S	-15	-1,5	119.99	1
5204048	6	8	S	-15	-1,5	2000	1
5204080	1	8	S	0	0	0	1
5204080	2	8	S	0	0	639	1
5204080	3	8	S	-240	-24	640	1
5204080	4	8	S	-240	-24	2000	1
5204111	1	8	S	-2	-0,2	0	1
5204111	2	8	S	-2	-0,2	2000	1
5204114	1	8	S	0	0	0	1
5204114	2	8	S	0	0	2000	1
5204114	3	8	S	0	0	3	1
5204114	4	8	S	0	0	2000	1
5204114	5	8	S	0	0	10	1
5204114	6	8	S	0	0	25.99	1
5204114	7	8	S	0	0	26	1
5204114	8	8	S	0	0	34.99	1
5204114	9	8	S	0	0	35	1
5204114	10	8	S	0	0	38.99	1
5204114	11	8	S	0	0	39	1
5204114	12	8	S	0	0	60.99	1
5204114	13	8	S	0	0	61	1
5204114	14	8	S	0	0	63.99	1
5204114	15	8	S	0	0	64	1
5204114	16	8	S	0	0	66.99	1
5204114	17	8	S	0	0	67	1
5204114	18	8	S	0	0	199.99	1
5204114	19	8	S	-1000	-100	200	1
5204114	20	8	S	-1000	-100	200.99	1
5204114	21	8	S	-2000	-200	201	1
5204114	22	8	S	-2000	-200	201.99	1
5204114	23	8	S	-3000	-300	202	1
5204114	24	8	S	-3000	-300	202.99	1
5204114	25	8	S	-6000	-600	203	1
5204114	26	8	S	-6000	-600	205.99	1
5204114	27	8	S	-10000	-1000	206	1
5204114	28	8	S	-10000	-1000	209.99	1
5204114	29	8	S	-75680	-7568	210	1
5204114	30	8	S	-75680	-7568	2000	1
5204150	1	8	S	0	0	0	1
5204150	2	8	S	0	0	35.99	1

Table C19 Market bids for time interval 08:00-09:00 (continued)

5204150	3	8	S	0	0	36	1
5204150	4	8	S	0	0	168.99	1
5204150	5	8	S	0	0	169	1
5204150	6	8	S	0	0	2000	1
5204170	1	8	S	582	58,2	0	1
5204170	2	8	S	582	58,2	33.99	1
5204170	3	8	S	0	0	34	1
5204170	4	8	S	0	0	171.99	1
5204170	5	8	S	0	0	172	1
5204170	6	8	S	0	0	2000	1
5204209	1	8	S	40	4	0	1
5204209	2	8	S	40	4	169.93	1
5204209	3	8	S	40	4	169.94	1
5204209	4	8	S	40	4	2000	1
5204223	1	8	S	0	0	0	1
5204223	2	8	S	0	0	61.99	1
5204223	3	8	S	0	0	62	1
5204223	4	8	S	0	0	174.99	1
5204223	5	8	S	0	0	175	1
5204223	6	8	S	0	0	2000	1
5204243	1	8	S	0	0	0	1
5204243	2	8	S	0	0	65.99	1
5204243	3	8	S	0	0	66	1
5204243	4	8	S	0	0	345.99	1
5204243	5	8	S	-1279	-127,9	346	1
5204243	6	8	S	-1279	-127,9	2000	1
5204316	1	8	S	1458	145,8	0	1
5204316	2	8	S	1458	145,8	2000	1
5204374	1	8	S	-39	-3,9	0	1
5204374	2	8	S	-39	-3,9	2000	1
5204402	1	8	S	4998	499,8	0	1
5204402	2	8	S	4998	499,8	2000	1
5204425	1	8	S	-45	-4,5	0	1
5204425	2	8	S	-45	-4,5	2000	1
5204469	1	8	S	-826	-82,6	0	1
5204469	2	8	S	-826	-82,6	77.99	1
5204469	3	8	S	-826	-82,6	78	1
5204469	4	8	S	-826	-82,6	100.79	1
5204469	5	8	S	-826	-82,6	100.8	1
5204469	6	8	S	-826	-82,6	110.27	1
5204469	7	8	S	-851	-85,1	110.28	1

Table C20 Market bids for time interval 08:00-09:00 (continued)

5204469	8	8	S	-851	-85,1	132.51	1
5204469	9	8	S	-851	-85,1	132.52	1
5204469	10	8	S	-851	-85,1	205.69	1
5204469	11	8	S	-1093	-109,3	205.7	1
5204469	12	8	S	-1093	-109,3	224.69	1
5204469	13	8	S	-1345	-134,5	224.7	1
5204469	14	8	S	-1345	-134,5	2000	1
5204508	1	8	S	7	0,7	0	1
5204508	2	8	S	7	0,7	2000	1
5204528	1	8	S	0	0	0	1
5204528	2	8	S	0	0	2000	1
5204528	3	8	S	-21	-2,1	10	1
5204528	4	8	S	-21	-2,1	50	1
5204528	5	8	S	-21	-2,1	100	1
5204528	6	8	S	-21	-2,1	150	1
5204528	7	8	S	-21	-2,1	189.99	1
5204528	8	8	S	-81	-8,1	190	1
5204528	9	8	S	-81	-8,1	200	1
5204528	10	8	S	-81	-8,1	250	1
5204528	11	8	S	-81	-8,1	300	1
5204528	12	8	S	-81	-8,1	350	1
5204528	13	8	S	-81	-8,1	400	1
5204528	14	8	S	-81	-8,1	449.99	1
5204528	15	8	S	-411	-41,1	450	1
5204528	16	8	S	-411	-41,1	750	1
5204528	17	8	S	-411	-41,1	1000	1
5204528	18	8	S	-411	-41,1	1500	1
5204528	19	8	S	-411	-41,1	2000	1
5204556	1	8	S	200	20	0	1
5204556	2	8	S	125	12,5	130	1
5204556	3	8	S	0	0	2000	1
5204571	1	8	S	30	3	0	1
5204571	2	8	S	30	3	99.99	1
5204571	3	8	S	30	3	100	1
5204571	4	8	S	30	3	140	1
5204571	5	8	S	30	3	180	1
5204571	6	8	S	30	3	2000	1
5204643	1	8	S	0	0	0	1
5204643	2	8	S	0	0	2000	1
5204781	1	8	S	0	0	0	1
5204781	2	8	S	0	0	2000	1

Table C21 Market bids for time interval 08:00-09:00 (continued)

5204849	1	8	S	0	0	0	1
5204849	2	8	S	0	0	179.99	1
5204849	3	8	S	0	0	180	1
5204849	4	8	S	0	0	200	1
5204849	5	8	S	0	0	2000	1
5204852	1	8	S	-9	-0,9	0	1
5204852	2	8	S	-9	-0,9	2000	1
5204908	1	8	S	10	1	0	1
5204908	2	8	S	10	1	2000	1
5205004	1	8	S	-40	-4	0	1
5205004	2	8	S	-40	-4	2000	1
5205128	1	8	S	-490	-49	0	1
5205128	2	8	S	-490	-49	2000	1
5205158	1	8	S	302	30,2	0	1
5205158	2	8	S	302	30,2	259.99	1
5205158	3	8	S	-58	-5,8	260	1
5205158	4	8	S	-58	-5,8	2000	1
5205222	1	8	S	300	30	0	1
5205222	2	8	S	300	30	115	1
5205222	3	8	S	0	0	115.01	1
5205222	4	8	S	0	0	131.99	1
5205222	5	8	S	-2310	-231	132	1
5205222	6	8	S	-2310	-231	191.99	1
5205222	7	8	S	-2980	-298	192	1
5205222	8	8	S	-2980	-298	2000	1
5205288	1	8	S	-14	-1,4	0	1
5205288	2	8	S	-14	-1,4	2000	1
5205310	1	8	S	0	0	0	1
5205310	2	8	S	0	0	174.46	1
5205310	3	8	S	-410	-41	174.47	1
5205310	4	8	S	-410	-41	2000	1
5205318	1	8	S	-80	-8	0	1
5205318	2	8	S	-80	-8	99.99	1
5205318	3	8	S	-80	-8	100	1
5205318	4	8	S	-80	-8	140	1
5205318	5	8	S	-80	-8	180	1
5205318	6	8	S	-80	-8	2000	1
5205502	1	8	S	339	33,9	0	1
5205502	2	8	S	339	33,9	2000	1
5205595	1	8	S	-21	-2,1	0	1
5205595	2	8	S	-21	-2,1	2000	1

Table C22 Market bids for time interval 08:00-09:00 (continued)

5205620	1	8	S	-135	-13,5	0	1
5205620	2	8	S	-135	-13,5	2000	1
5205684	1	8	S	-17	-1,7	0	1
5205684	2	8	S	-17	-1,7	2000	1
5205725	1	8	S	-215	-21,5	0	1
5205725	2	8	S	-215	-21,5	2000	1
5205761	1	8	S	155	15,5	0	1
5205761	2	8	S	155	15,5	2000	1
5205809	1	8	S	0	0	0	1
5205809	2	8	S	0	0	2000	1
5205836	1	8	S	-148	-14,8	0	1
5205836	2	8	S	-148	-14,8	2000	1
5205869	1	8	S	25	2,5	0	1
5205869	2	8	S	25	2,5	2000	1
5205947	1	8	S	754	75,4	0	1
5205947	2	8	S	754	75,4	49.99	1
5205947	3	8	S	564	56,4	50	1
5205947	4	8	S	564	56,4	140	1
5205947	5	8	S	-196	-19,6	140.01	1
5205947	6	8	S	-196	-19,6	144.99	1
5205947	7	8	S	-1636	-163,6	145	1
5205947	8	8	S	-1636	-163,6	2000	1
5205960	1	8	S	-33	-3,3	0	1
5205960	2	8	S	-33	-3,3	2000	1
5206314	1	8	S	0	0	0	1
5206314	2	8	S	0	0	2000	1
5206334	1	8	S	0	0	0	1
5206334	2	8	S	0	0	2000	1
5206423	1	8	S	1784	178,4	0	1
5206423	2	8	S	1784	178,4	2000	1
5206457	1	8	S	-27	-2,7	0	1
5206457	2	8	S	-27	-2,7	2000	1
5206461	1	8	S	3	0,3	0	1
5206461	2	8	S	3	0,3	2000	1
5206487	1	8	S	-120	-12	0	1
5206487	2	8	S	-120	-12	167.99	1
5206487	3	8	S	-1280	-128	168	1
5206487	4	8	S	-1280	-128	169.99	1
5206487	5	8	S	-2140	-214	170	1
5206487	6	8	S	-2140	-214	174.99	1
5206487	7	8	S	-2140	-214	175	1

Table C23 Market bids for time interval 08:00-09:00 (continued)

5206487	8	8	S	-2140	-214	2000	1
5206531	1	8	S	192	19,2	0	1
5206531	2	8	S	192	19,2	2000	1
5206543	1	8	S	0	0	0	1
5206543	2	8	S	0	0	2000	1
5206616	1	8	S	0	0	0	1
5206616	2	8	S	0	0	2000	1
5206667	1	8	S	127	12,7	0	1
5206667	2	8	S	127	12,7	2000	1
5206686	1	8	S	-7	-0,7	0	1
5206686	2	8	S	-7	-0,7	2000	1
5206732	1	8	S	421	42,1	0	1
5206732	2	8	S	421	42,1	2000	1
5206876	1	8	S	0	0	0	1
5206876	2	8	S	0	0	2000	1
5206883	1	8	S	1127	112,7	0	1
5206883	2	8	S	1127	112,7	2000	1
5206933	1	8	S	5	0,5	0	1
5206933	2	8	S	5	0,5	2000	1
5206953	1	8	S	9	0,9	0	1
5206953	2	8	S	9	0,9	2000	1
5207011	1	8	S	0	0	0	1
5207011	2	8	S	0	0	198.99	1
5207011	3	8	S	-1600	-160	199	1
5207011	4	8	S	-1600	-160	209.99	1
5207011	5	8	S	-4800	-480	210	1
5207011	6	8	S	-4800	-480	2000	1
5207140	1	8	S	-20	-2	0	1
5207140	2	8	S	-20	-2	2000	1
5207188	1	8	S	-220	-22	0	1
5207188	2	8	S	-220	-22	2000	1
5207293	1	8	S	5	0,5	0	1
5207293	2	8	S	5	0,5	59.99	1
5207293	3	8	S	5	0,5	70.99	1
5207293	4	8	S	0	0	80	1
5207293	5	8	S	0	0	119	1
5207293	6	8	S	0	0	120	1
5207293	7	8	S	0	0	149.99	1
5207293	8	8	S	0	0	169.99	1
5207293	9	8	S	0	0	172.99	1
5207293	10	8	S	-2	-0,2	179.99	1

Table C24 Market bids for time interval 08:00-09:00 (continued)

5207293	11	8	S	-2	-0,2	196.01	1
5207293	12	8	S	-2	-0,2	230	1
5207293	13	8	S	-20	-2	500	1
5207293	14	8	S	-30	-3	2000	1
5207379	1	8	S	-72	-7,2	0	1
5207379	2	8	S	-72	-7,2	2000	1
5207414	1	8	S	1584	158,4	0	1
5207414	2	8	S	1584	158,4	2000	1
5207493	1	8	S	-1098	-109,8	0	1
5207493	2	8	S	-1098	-109,8	2000	1
5207520	1	8	S	0	0	0	1
5207520	2	8	S	0	0	2000	1
5207558	1	8	S	4500	450	0	1
5207558	2	8	S	4500	450	140	1
5207558	3	8	S	4500	450	140.1	1
5207558	4	8	S	4500	450	150	1
5207558	5	8	S	4500	450	150.1	1
5207558	6	8	S	4500	450	200	1
5207558	7	8	S	4500	450	200.1	1
5207558	8	8	S	4500	450	300	1
5207558	9	8	S	4500	450	300.1	1
5207558	10	8	S	4500	450	500	1
5207558	11	8	S	4500	450	500.1	1
5207558	12	8	S	4500	450	1000	1
5207558	13	8	S	4500	450	1000.1	1
5207558	14	8	S	4500	450	2000	1
5207577	1	8	S	1	0,1	0	1
5207577	2	8	S	1	0,1	2000	1
5207607	1	8	S	33	3,3	0	1
5207607	2	8	S	33	3,3	2000	1
5207625	1	8	S	-6	-0,6	0	1
5207625	2	8	S	-6	-0,6	2000	1
5207706	1	8	S	42	4,2	0	1
5207706	2	8	S	42	4,2	2000	1
5207726	1	8	S	-19	-1,9	0	1
5207726	2	8	S	-19	-1,9	2000	1
5207754	1	8	S	8291	829,1	0	1
5207754	2	8	S	8291	829,1	35	1
5207754	3	8	S	5491	549,1	35.1	1
5207754	4	8	S	5491	549,1	40	1
5207754	5	8	S	5491	549,1	40.1	1

Table C25 Market bids for time interval 08:00-09:00 (continued)

5207754	6	8	S	5491	549,1	100	1
5207754	7	8	S	1201	120,1	100.1	1
5207754	8	8	S	1201	120,1	110	1
5207754	9	8	S	0	0	110.1	1
5207754	10	8	S	0	0	129.9	1
5207754	11	8	S	0	0	130	1
5207754	12	8	S	0	0	134.9	1
5207754	13	8	S	0	0	135	1
5207754	14	8	S	0	0	149.9	1
5207754	15	8	S	0	0	150	1
5207754	16	8	S	0	0	309.9	1
5207754	17	8	S	0	0	310	1
5207754	18	8	S	0	0	329.9	1
5207754	19	8	S	-387	-38,7	330	1
5207754	20	8	S	-387	-38,7	359.9	1
5207754	21	8	S	-571	-57,1	360	1
5207754	22	8	S	-571	-57,1	2000	1
5207829	1	8	S	-935	-93,5	0	1
5207829	2	8	S	-935	-93,5	2000	1
5207841	1	8	S	-300	-30	0	1
5207841	2	8	S	-300	-30	100	1
5207841	3	8	S	-300	-30	100.01	1
5207841	4	8	S	-300	-30	185	1
5207841	5	8	S	-2290	-229	185.01	1
5207841	6	8	S	-2290	-229	190	1
5207841	7	8	S	-2290	-229	190.01	1
5207841	8	8	S	-2290	-229	200	1
5207841	9	8	S	-2290	-229	200.01	1
5207841	10	8	S	-2290	-229	250	1
5207841	11	8	S	-2290	-229	2000	1
5207876	1	8	S	1	0,1	0	1
5207876	2	8	S	1	0,1	20	1
5207876	3	8	S	1	0,1	30	1
5207876	4	8	S	1	0,1	90	1
5207876	5	8	S	1	0,1	100	1
5207876	6	8	S	1	0,1	110	1
5207876	7	8	S	1	0,1	120	1
5207876	8	8	S	1	0,1	132	1
5207876	9	8	S	1	0,1	145	1
5207876	10	8	S	1	0,1	150	1
5207876	11	8	S	-100	-10	155	1

Table C26 Market bids for time interval 08:00-09:00 (continued)

5207876	12	8	S	-100	-10	159	1
5207876	13	8	S	-130	-13	160	1
5207876	14	8	S	-220	-22	162	1
5207876	15	8	S	-240	-24	166	1
5207876	16	8	S	-250	-25	168	1
5207876	17	8	S	-300	-30	170	1
5207876	18	8	S	-450	-45	175	1
5207876	19	8	S	-580	-58	180	1
5207876	20	8	S	-580	-58	182	1
5207876	21	8	S	-580	-58	185	1
5207876	22	8	S	-580	-58	187	1
5207876	23	8	S	-580	-58	190	1
5207876	24	8	S	-580	-58	193	1
5207876	25	8	S	-600	-60	195	1
5207876	26	8	S	-600	-60	197	1
5207876	27	8	S	-600	-60	205	1
5207876	28	8	S	-600	-60	210	1
5207876	29	8	S	-600	-60	215	1
5207876	30	8	S	-600	-60	220	1
5207876	31	8	S	-600	-60	225	1
5207876	32	8	S	-600	-60	230	1
5207876	33	8	S	-600	-60	240	1
5207876	34	8	S	-600	-60	250	1
5207876	35	8	S	-600	-60	300	1
5207876	36	8	S	-600	-60	400	1
5207876	37	8	S	-600	-60	2000	1
5208004	1	8	S	61	6,1	0	1
5208004	2	8	S	61	6,1	2000	1
5208021	1	8	S	0	0	0	1
5208021	2	8	S	0	0	23.13	1
5208021	3	8	S	-30	-3	23.14	1
5208021	4	8	S	-60	-6	23.15	1
5208021	5	8	S	-60	-6	2000	1
5208089	1	8	S	0	0	0	1
5208089	2	8	S	0	0	2000	1
5208167	1	8	S	26	2,6	0	1
5208167	2	8	S	26	2,6	2000	1
5208339	1	8	S	0	0	0	1
5208339	2	8	S	0	0	2000	1
5208387	1	8	S	-91	-9,1	0	1
5208387	2	8	S	-91	-9,1	2000	1

Table C27 Market bids for time interval 08:00-09:00 (continued)

5208434	1	8	S	-1640	-164	0	1
5208434	2	8	S	-1640	-164	89.99	1
5208434	3	8	S	-1640	-164	90	1
5208434	4	8	S	-1640	-164	2000	1
5208445	1	8	S	55	5,5	0	1
5208445	2	8	S	55	5,5	250	1
5208445	3	8	S	0	0	250.01	1
5208445	4	8	S	0	0	2000	1
5208508	1	8	S	-7	-0,7	0	1
5208508	2	8	S	-7	-0,7	2000	1
5208525	1	8	S	24	2,4	0	1
5208525	2	8	S	24	2,4	2000	1
5208550	1	8	S	470	47	0	1
5208550	2	8	S	470	47	77.75	1
5208550	3	8	S	470	47	77.76	1
5208550	4	8	S	470	47	144.99	1
5208550	5	8	S	-350	-35	145	1
5208550	6	8	S	-350	-35	164.99	1
5208550	7	8	S	-350	-35	165	1
5208550	8	8	S	-350	-35	169.99	1
5208550	9	8	S	-350	-35	170	1
5208550	10	8	S	-350	-35	174.99	1
5208550	11	8	S	-350	-35	175	1
5208550	12	8	S	-350	-35	180.44	1
5208550	13	8	S	-930	-93	180.45	1
5208550	14	8	S	-930	-93	322.84	1
5208550	15	8	S	-930	-93	322.85	1
5208550	16	8	S	-930	-93	2000	1
5208624	1	8	S	-22	-2,2	0	1
5208624	2	8	S	-22	-2,2	2000	1
5208683	1	8	S	265	26,5	0	1
5208683	2	8	S	265	26,5	169.99	1
5208683	3	8	S	180	18	170	1
5208683	4	8	S	180	18	2000	1
5208804	1	8	S	1259	125,9	0	1
5208804	2	8	S	1259	125,9	2000	1
5208813	1	8	S	304	30,4	0	1
5208813	2	8	S	304	30,4	2000	1
5208856	1	8	S	-25	-2,5	0	1
5208856	2	8	S	-25	-2,5	2000	1
5208869	1	8	S	0	0	0	1

Table C28 Market bids for time interval 08:00-09:00 (continued)

5208869	2	8	S	0	0	2000	1
5208945	1	8	S	0	0	0	1
5208945	2	8	S	-125	-12,5	150	1
5208945	3	8	S	-139	-13,9	180	1
5208945	4	8	S	-140	-14	2000	1
5208987	1	8	S	10	1	0	1
5208987	2	8	S	10	1	144	1
5208987	3	8	S	0	0	184.99	1
5208987	4	8	S	-80	-8	185	1
5208987	5	8	S	-80	-8	2000	1
5209020	1	8	S	0	0	0	1
5209020	2	8	S	0	0	10	1
5209020	3	8	S	0	0	150	1
5209020	4	8	S	0	0	174	1
5209020	5	8	S	0	0	174.01	1
5209020	6	8	S	0	0	187	1
5209020	7	8	S	0	0	187.01	1
5209020	8	8	S	0	0	194.59	1
5209020	9	8	S	-60	-6	194.6	1
5209020	10	8	S	-60	-6	198	1
5209020	11	8	S	-60	-6	198.01	1
5209020	12	8	S	-60	-6	201.59	1
5209020	13	8	S	-135	-13,5	201.6	1
5209020	14	8	S	-135	-13,5	204.59	1
5209020	15	8	S	-325	-32,5	204.6	1
5209020	16	8	S	-325	-32,5	209.59	1
5209020	17	8	S	-588	-58,8	209.6	1
5209020	18	8	S	-588	-58,8	2000	1
5209146	1	8	S	17	1,7	0	1
5209146	2	8	S	17	1,7	101	1
5209146	3	8	S	-33	-3,3	101.01	1
5209146	4	8	S	-33	-3,3	2000	1
5209190	1	8	S	3	0,3	0	1
5209190	2	8	S	3	0,3	2000	1
5209229	1	8	S	1	0,1	0	1
5209229	2	8	S	1	0,1	2000	1
5209272	1	8	S	-352	-35,2	0	1
5209272	2	8	S	-352	-35,2	2000	1
5209305	1	8	S	490	49	0	1
5209305	2	8	S	490	49	100	1
5209305	3	8	S	300	30	100.01	1

Table C29 Market bids for time interval 08:00-09:00 (continued)

5209305	4	8	S	300	30	2000	1
5209328	1	8	S	0	0	0	1
5209328	2	8	S	-14	-1,4	35	1
5209328	3	8	S	-14	-1,4	2000	1
5209361	1	8	S	-264	-26,4	0	1
5209361	2	8	S	-264	-26,4	2000	1

C.2 Data for Chapter 7.3 and 7.4

Appendix C.2 includes the real data used in Chapter 7.3 and Chapter 7.4 simulations. Data is obtained by MFSC.

Table C30 Market bids for time interval 11:00-12:00

ID	SEVIYE	SAAT	TİP	LOT	MWh	FIYAT	SURE
5142092	1	11	S	0	0	0	1
5142092	2	11	S	0	0	2000	1
5142509	1	11	S	0	0	0	1
5142509	2	11	S	0	0	2000	1
5142870	1	11	B	25	2,5	2000	2
5143589	1	11	S	252	25,2	0	1
5143589	2	11	S	252	25,2	100	1
5143589	3	11	S	252	25,2	120	1
5143589	4	11	S	252	25,2	135	1
5143589	5	11	S	252	25,2	2000	1
5143963	1	11	S	-85	-8,5	0	1
5143963	2	11	S	-85	-8,5	2000	1
5145177	1	11	S	-15	-1,5	0	1
5145177	2	11	S	-15	-1,5	2000	1
5145950	1	11	S	2	0,2	0	1
5145950	2	11	S	2	0,2	2000	1
5150282	1	11	S	0	0	0	1
5150282	2	11	S	0	0	2000	1
5152785	1	11	S	191	19,1	0	1
5152785	2	11	S	191	19,1	500	1
5152785	3	11	S	0	0	500.01	1
5152785	4	11	S	0	0	2000	1
5152802	1	11	S	5000	500	0	1
5152802	2	11	S	340	34	0.99	1
5152802	3	11	S	340	34	2000	1

Table C31 Market bids for time interval 11:00-12:00
(continued)

5152854	1	11	S	70	7	0	1
5152854	2	11	S	70	7	200	1
5152854	3	11	S	1	0,1	201	1
5152854	4	11	S	0	0	2000	1
5152939	1	11	S	3102	310,2	0	1
5152939	2	11	S	3102	310,2	180	1
5152939	3	11	S	3102	310,2	180.01	1
5152939	4	11	S	3102	310,2	250	1
5152939	5	11	S	0	0	250.01	1
5152939	6	11	S	0	0	2000	1
5153193	1	11	S	7	0,7	0	1
5153193	2	11	S	7	0,7	2000	1
5153538	1	11	S	16	1,6	0	1
5153538	2	11	S	16	1,6	234.99	1
5153538	3	11	S	16	1,6	2000	1
5154527	1	11	S	0	0	0	1
5154527	2	11	S	0	0	186.86	1
5154527	3	11	S	-193	-19,3	186.87	1
5154527	4	11	S	-193	-19,3	2000	1
5155726	1	11	S	300	30	0	1
5155726	2	11	S	300	30	75	1
5155726	3	11	S	-700	-70	75.01	1
5155726	4	11	S	-700	-70	89.99	1
5155726	5	11	S	-700	-70	90	1
5155726	6	11	S	-700	-70	99.99	1
5155726	7	11	S	-1775	177,5	100	1
5155726	8	11	S	-1775	177,5	109.99	1
5155726	9	11	S	-1775	177,5	110	1
5155726	10	11	S	-1775	177,5	119.99	1
5155726	11	11	S	-2165	216,5	120	1
5155726	12	11	S	-2165	216,5	129.99	1
5155726	13	11	S	-2265	226,5	130	1
5155726	14	11	S	-2265	226,5	139.99	1
5155726	15	11	S	-2265	226,5	140	1
5155726	16	11	S	-2265	226,5	2000	1
5155825	1	11	S	16	1,6	0	1
5155825	2	11	S	16	1,6	2000	1
5160378	1	11	S	0	0	0	1
5160378	2	11	S	0	0	193.98	1
5160378	3	11	S	-47	-4,7	193.99	1
5160378	4	11	S	-47	-4,7	398.99	1

**Table C32 Market bids for time interval 11:00-12:00
(continued)**

5160378	5	11	S	-50	-5	399	1
5160378	6	11	S	-50	-5	1990	1
5160378	7	11	S	-100	-10	1990.01	1
5160378	8	11	S	-100	-10	2000	1
5160440	1	11	S	26	2,6	0	1
5160440	2	11	S	26	2,6	2000	1
5160791	1	11	S	1	0,1	0	1
5160791	2	11	S	1	0,1	2000	1
5161268	1	11	S	0	0	0	1
5161268	2	11	S	-200	-20	175	1
5161268	3	11	S	-450	-45	195	1
5161268	4	11	S	-450	-45	195.01	1
5161268	5	11	S	-550	-55	195.02	1
5161268	6	11	S	-550	-55	199.99	1
5161268	7	11	S	-750	-75	200	1
5161268	8	11	S	-750	-75	204.99	1
5161268	9	11	S	-950	-95	205	1
5161268	10	11	S	-950	-95	205.01	1
5161268	11	11	S	-1200	-120	2000	1
5161728	1	11	S	-10	-1	0	1
5161728	2	11	S	-10	-1	2000	1
5164317	1	11	S	-8	-0,8	0	1
5164317	2	11	S	-8	-0,8	2000	1
5164544	1	11	S	157	15,7	0	1
5164544	2	11	S	157	15,7	2000	1
5164624	1	11	S	3700	370	0	1
5164624	2	11	S	3700	370	120	1
5164624	3	11	S	3700	370	120.01	1
5164624	4	11	S	3700	370	140	1
5164624	5	11	S	3700	370	140.01	1
5164624	6	11	S	3700	370	160	1
5164624	7	11	S	3700	370	160.01	1
5164624	8	11	S	3700	370	180	1
5164624	9	11	S	2775	277,5	180.01	1
5164624	10	11	S	2775	277,5	200	1
5164624	11	11	S	0	0	200.01	1
5164624	12	11	S	0	0	225	1
5164624	13	11	S	0	0	2000	1
5164706	1	11	S	30	3	0	1
5164706	2	11	S	20	2	140	1
5164706	3	11	S	20	2	165	1

**Table C33 Market bids for time interval 11:00-12:00
(continued)**

5164706	4	11	S	0	0	175	1
5164706	5	11	S	0	0	180	1
5164706	6	11	S	-30	-3	185	1
5164706	7	11	S	-35	-3,5	200	1
5164706	8	11	S	-50	-5	2000	1
5164904	1	11	S	120	12	0	1
5164904	2	11	S	120	12	139.98	1
5164904	3	11	S	0	0	139.99	1
5164904	4	11	S	0	0	187.63	1
5164904	5	11	S	-300	-30	187.64	1
5164904	6	11	S	-300	-30	2000	1
5165252	1	11	S	-137	-13,7	0	1
5165252	2	11	S	-137	-13,7	2000	1
5165358	1	11	S	-6	-0,6	0	1
5165358	2	11	S	-6	-0,6	2000	1
5165420	1	11	S	0	0	0	1
5165420	2	11	S	0	0	189.86	1
5165420	3	11	S	-183	-18,3	189.87	1
5165420	4	11	S	-183	-18,3	2000	1
5165725	1	11	S	19	1,9	0	1
5165725	2	11	S	19	1,9	2000	1
5166320	1	11	S	12	1,2	0	1
5166320	2	11	S	12	1,2	2000	1
5167404	1	11	S	17	1,7	0	1
5167404	2	11	S	17	1,7	2000	1
5167537	1	11	S	-8	-0,8	0	1
5167537	2	11	S	-8	-0,8	2000	1
5169021	1	11	S	10	1	0	1
5169021	2	11	S	10	1	634.99	1
5169021	3	11	S	-300	-30	635	1
5169021	4	11	S	-300	-30	654.99	1
5169021	5	11	S	-650	-65	655	1
5169021	6	11	S	-650	-65	2000	1
5169678	1	11	S	-233	-23,3	0	1
5169678	2	11	S	-233	-23,3	2000	1
5170011	1	11	S	-16	-1,6	0	1
5170011	2	11	S	-16	-1,6	2000	1
5170260	1	11	S	30	3	0	1
5170260	2	11	S	30	3	2000	1
5170459	1	11	S	126	12,6	0	1
5170459	2	11	S	126	12,6	2000	1

**Table C34 Market bids for time interval 11:00-12:00
(continued)**

5171773	1	11	S	-2	-0,2	0	1
5171773	2	11	S	-2	-0,2	2000	1
5173057	1	11	S	28	2,8	0	1
5173057	2	11	S	28	2,8	2000	1
5173406	1	11	S	0	0	0	1
5173406	2	11	S	0	0	250.98	1
5173406	3	11	S	-68	-6,8	250.99	1
5173406	4	11	S	-68	-6,8	2000	1
5174427	1	11	S	-1	-0,1	0	1
5174427	2	11	S	-1	-0,1	2000	1
5178506	1	11	S	0	0	0	1
5178506	2	11	S	0	0	164.59	1
5178506	3	11	S	-22	-2,2	164.6	1
5178506	4	11	S	-22	-2,2	175	1
5178506	5	11	S	-22	-2,2	500	1
5178506	6	11	S	-22	-2,2	2000	1
5178726	1	11	S	0	0	0	1
5178726	2	11	S	0	0	639	1
5178726	3	11	S	-240	-24	640	1
5178726	4	11	S	-240	-24	2000	1
5179220	1	11	S	0	0	0	1
5179220	2	11	S	0	0	639	1
5179220	3	11	S	-300	-30	640	1
5179220	4	11	S	-300	-30	2000	1
5179417	1	11	S	4	0,4	0	1
5179417	2	11	S	4	0,4	2000	1
5180281	1	11	S	-35	-3,5	0	1
5180281	2	11	S	-35	-3,5	2000	1
5180470	1	11	S	0	0	0	1
5180470	2	11	S	0	0	2000	1
5180706	1	11	S	1920	192	0	1
5180706	2	11	S	1920	192	200	1
5180706	3	11	S	0	0	250	1
5180706	4	11	S	0	0	2000	1
5180717	1	11	S	-57	-5,7	0	1
5180717	2	11	S	-57	-5,7	2000	1
5181142	1	11	S	-728	-72,8	0	1
5181142	2	11	S	-728	-72,8	2000	1
5181249	1	11	S	35	3,5	0	1
5181249	2	11	S	35	3,5	2000	1
5181470	1	11	S	8	0,8	0	1

**Table C35 Market bids for time interval 11:00-12:00
(continued)**

5181470	2	11	S	8	0,8	200	1
5181470	3	11	S	0	0	200.01	1
5181470	4	11	S	0	0	2000	1
5182058	1	11	S	17	1,7	0	1
5182058	2	11	S	17	1,7	2000	1
5182356	1	11	S	20	2	0	1
5182356	2	11	S	20	2	300	1
5182356	3	11	S	0	0	2000	1
5182541	1	11	S	-3	-0,3	0	1
5182541	2	11	S	-3	-0,3	2000	1
5182620	1	11	S	51	5,1	0	1
5182620	2	11	S	51	5,1	2000	1
5183776	1	11	S	-6	-0,6	0	1
5183776	2	11	S	-6	-0,6	2000	1
5184065	1	11	S	109	10,9	0	1
5184065	2	11	S	108	10,8	90	1
5184065	3	11	S	107	10,7	110	1
5184065	4	11	S	106	10,6	120	1
5184065	5	11	S	105	10,5	155	1
5184065	6	11	S	0	0	2000	1
5185247	1	11	S	-6	-0,6	0	1
5185247	2	11	S	-6	-0,6	2000	1
5186305	1	11	S	0	0	0	1
5186305	2	11	S	0	0	149	1
5186305	3	11	S	-2	-0,2	150	1
5186305	4	11	S	-2	-0,2	2000	1
5190673	1	11	S	0	0	0	1
5190673	2	11	S	-13	-1,3	100	1
5190673	3	11	S	-13	-1,3	100.01	1
5190673	4	11	S	-13	-1,3	2000	1
5191124	1	11	S	0	0	0	1
5191124	2	11	S	0	0	2000	1
5191211	1	11	S	7130	713	0	1
5191211	2	11	S	7130	713	150	1
5191211	3	11	S	7130	713	151	1
5191211	4	11	S	7130	713	200	1
5191211	5	11	S	7130	713	200.01	1
5191211	6	11	S	7130	713	250	1
5191211	7	11	S	3600	360	250.01	1
5191211	8	11	S	3600	360	300	1
5191211	9	11	S	0	0	300.01	1

**Table C36 Market bids for time interval 11:00-12:00
(continued)**

5191211	10	11	S	0	0	320	1
5191211	11	11	S	0	0	320.01	1
5191211	12	11	S	0	0	400	1
5191211	13	11	S	0	0	400.01	1
5191211	14	11	S	0	0	2000	1
5191361	1	11	S	-3	-0,3	0	1
5191361	2	11	S	-3	-0,3	2000	1
5191459	1	11	S	21	2,1	0	1
5191459	2	11	S	0	0	2000	1
5192632	1	11	S	2	0,2	0	1
5192632	2	11	S	2	0,2	214.93	1
5192632	3	11	S	-170	-17	214.94	1
5192632	4	11	S	-170	-17	2000	1
5192789	1	11	S	0	0	0	1
5192789	2	11	S	0	0	2000	1
5192975	1	11	S	0	0	0	1
5192975	2	11	S	0	0	185	1
5192975	3	11	S	-485	-48,5	185.01	1
5192975	4	11	S	-485	-48,5	250	1
5192975	5	11	S	-485	-48,5	250.01	1
5192975	6	11	S	-485	-48,5	2000	1
5197524	1	11	S	8	0,8	0	1
5197524	2	11	S	7	0,7	50	1
5197524	3	11	S	5	0,5	50.1	1
5197524	4	11	S	4	0,4	100	1
5197524	5	11	S	4	0,4	100.1	1
5197524	6	11	S	4	0,4	125	1
5197524	7	11	S	4	0,4	125.1	1
5197524	8	11	S	4	0,4	150	1
5197524	9	11	S	3	0,3	150.1	1
5197524	10	11	S	3	0,3	175	1
5197524	11	11	S	3	0,3	175.1	1
5197524	12	11	S	3	0,3	185	1
5197524	13	11	S	2	0,2	185.1	1
5197524	14	11	S	2	0,2	197.1	1
5197524	15	11	S	2	0,2	197.2	1
5197524	16	11	S	2	0,2	205	1
5197524	17	11	S	2	0,2	214.1	1
5197524	18	11	S	0	0	215	1
5197524	19	11	S	0	0	2000	1
5197667	1	11	S	100	10	0	1

**Table C37 Market bids for time interval 11:00-12:00
(continued)**

5197667	2	11	S	100	10	2000	1
5197726	1	11	S	25	2,5	0	1
5197726	2	11	S	25	2,5	130	1
5197726	3	11	S	25	2,5	140	1
5197726	4	11	S	25	2,5	145	1
5197726	5	11	S	25	2,5	150	1
5197726	6	11	S	25	2,5	155	1
5197726	7	11	S	25	2,5	160	1
5197726	8	11	S	25	2,5	165	1
5197726	9	11	S	25	2,5	170	1
5197726	10	11	S	25	2,5	175	1
5197726	11	11	S	25	2,5	180	1
5197726	12	11	S	25	2,5	185	1
5197726	13	11	S	25	2,5	190	1
5197726	14	11	S	25	2,5	195	1
5197726	15	11	S	25	2,5	200	1
5197726	16	11	S	25	2,5	205	1
5197726	17	11	S	25	2,5	210	1
5197726	18	11	S	25	2,5	220	1
5197726	19	11	S	25	2,5	250	1
5197726	20	11	S	25	2,5	350	1
5197726	21	11	S	25	2,5	500	1
5197726	22	11	S	25	2,5	750	1
5197726	23	11	S	25	2,5	1000	1
5197726	24	11	S	25	2,5	1250	1
5197726	25	11	S	25	2,5	1500	1
5197726	26	11	S	25	2,5	1750	1
5197726	27	11	S	25	2,5	2000	1
5197748	1	11	S	1400	140	0	1
5197748	2	11	S	1400	140	100	1
5197748	3	11	S	1400	140	125	1
5197748	4	11	S	1400	140	150	1
5197748	5	11	S	1400	140	175	1
5197748	6	11	S	1400	140	200	1
5197748	7	11	S	1400	140	225	1
5197748	8	11	S	1400	140	250	1
5197748	9	11	S	1400	140	275	1
5197748	10	11	S	1400	140	300	1
5197748	11	11	S	1400	140	325	1
5197748	12	11	S	1400	140	350	1
5197748	13	11	S	1400	140	375	1

**Table C38 Market bids for time interval 11:00-12:00
(continued)**

5197748	14	11	S	1400	140	400	1
5197748	15	11	S	1400	140	425	1
5197748	16	11	S	1400	140	450	1
5197748	17	11	S	1400	140	475	1
5197748	18	11	S	1400	140	500	1
5197748	19	11	S	0	0	500.01	1
5197748	20	11	S	0	0	2000	1
5197771	1	11	S	4	0,4	0	1
5197771	2	11	S	4	0,4	200.02	1
5197771	3	11	S	0	0	200.03	1
5197771	4	11	S	0	0	2000	1
5198025	1	11	S	-100	-10	0	1
5198025	2	11	S	-100	-10	2000	1
5198074	1	11	S	74	7,4	0	1
5198074	2	11	S	74	7,4	70	1
5198074	3	11	S	64	6,4	70.01	1
5198074	4	11	S	64	6,4	200	1
5198074	5	11	S	54	5,4	200.01	1
5198074	6	11	S	54	5,4	2000	1
5198236	1	11	S	-15	-1,5	0	1
5198236	2	11	S	-15	-1,5	2000	1
5198339	1	11	S	37	3,7	0	1
5198339	2	11	S	37	3,7	210	1
5198339	3	11	S	-33	-3,3	211	1
5198339	4	11	S	-33	-3,3	700	1
5198339	5	11	S	-33	-3,3	701	1
5198339	6	11	S	-33	-3,3	2000	1
5198481	1	11	S	9	0,9	0	1
5198481	2	11	S	9	0,9	2000	1
5198559	1	11	S	0	0	0	1
5198559	2	11	S	0	0	49.98	1
5198559	3	11	S	-4	-0,4	49.99	1
5198559	4	11	S	-4	-0,4	50	1
5198559	5	11	S	-4	-0,4	2000	1
5198566	1	11	S	-10	-1	0	1
5198566	2	11	S	-10	-1	2000	1
5198654	1	11	S	-40	-4	0	1
5198654	2	11	S	-40	-4	2000	1
5198673	1	11	S	-6	-0,6	0	1
5198673	2	11	S	-6	-0,6	2000	1
5198772	1	11	S	36	3,6	0	1

Table C39 Market bids for time interval 11:00-12:00
(continued)

5198772	2	11	S	36	3,6	2000	1
5198790	1	11	S	-2	-0,2	0	1
5198790	2	11	S	-2	-0,2	2000	1
5198820	1	11	S	49	4,9	0	1
5198820	2	11	S	49	4,9	89.9	1
5198820	3	11	S	49	4,9	90	1
5198820	4	11	S	49	4,9	129.9	1
5198820	5	11	S	35	3,5	130	1
5198820	6	11	S	35	3,5	174.9	1
5198820	7	11	S	35	3,5	175	1
5198820	8	11	S	35	3,5	270	1
5198820	9	11	S	0	0	350	1
5198820	10	11	S	0	0	2000	1
5198839	1	11	S	-50	-5	0	1
5198839	2	11	S	-50	-5	2000	1
5198879	1	11	S	-15	-1,5	0	1
5198879	2	11	S	-15	-1,5	2000	1
5198996	1	11	S	-20	-2	0	1
5198996	2	11	S	-20	-2	2000	1
5198999	1	11	S	0	0	0	1
5198999	2	11	S	0	0	98.99	1
5198999	3	11	S	-60	-6	99	1
5198999	4	11	S	-60	-6	2000	1
5199128	1	11	S	-104	-10,4	0	1
5199128	2	11	S	-104	-10,4	2000	1
5199158	1	11	S	28	2,8	0	1
5199158	2	11	S	28	2,8	2000	1
5199166	1	11	S	0	0	0	1
5199166	2	11	S	0	0	2000	1
5199629	1	11	S	928	92,8	0	1
5199629	2	11	S	928	92,8	2000	1
5199661	1	11	S	950	95	0	1
5199661	2	11	S	950	95	196	1
5199661	3	11	S	950	95	196.01	1
5199661	4	11	S	950	95	206	1
5199661	5	11	S	950	95	206.01	1
5199661	6	11	S	950	95	216	1
5199661	7	11	S	950	95	216.01	1
5199661	8	11	S	950	95	226	1
5199661	9	11	S	0	0	226.01	1
5199661	10	11	S	0	0	2000	1

**Table C40 Market bids for time interval 11:00-12:00
(continued)**

5199690	1	11	S	0	0	0	1
5199690	2	11	S	0	0	209.37	1
5199690	3	11	S	-669	-66,9	209.38	1
5199690	4	11	S	-669	-66,9	299.37	1
5199690	5	11	S	-1891	189,1	299.38	1
5199690	6	11	S	-1891	189,1	2000	1
5199769	1	11	S	0	0	0	1
5199769	2	11	S	0	0	2000	1
5199845	1	11	S	0	0	0	1
5199845	2	11	S	0	0	209.41	1
5199845	3	11	S	-233	-23,3	209.42	1
5199845	4	11	S	-233	-23,3	299.41	1
5199845	5	11	S	-698	-69,8	299.42	1
5199845	6	11	S	-698	-69,8	2000	1
5199888	1	11	S	33	3,3	0	1
5199888	2	11	S	33	3,3	100	1
5199888	3	11	S	33	3,3	110	1
5199888	4	11	S	33	3,3	120	1
5199888	5	11	S	33	3,3	125	1
5199888	6	11	S	33	3,3	130	1
5199888	7	11	S	33	3,3	135	1
5199888	8	11	S	33	3,3	140	1
5199888	9	11	S	33	3,3	145	1
5199888	10	11	S	33	3,3	150	1
5199888	11	11	S	33	3,3	155	1
5199888	12	11	S	33	3,3	160	1
5199888	13	11	S	33	3,3	165	1
5199888	14	11	S	33	3,3	170	1
5199888	15	11	S	33	3,3	175	1
5199888	16	11	S	33	3,3	180	1
5199888	17	11	S	33	3,3	185	1
5199888	18	11	S	33	3,3	190	1
5199888	19	11	S	33	3,3	200	1
5199888	20	11	S	0	0	201	1
5199888	21	11	S	0	0	2000	1
5199950	1	11	S	699	69,9	0	1
5199950	2	11	S	699	69,9	2000	1
5199965	1	11	S	20	2	0	1
5199965	2	11	S	20	2	999	1
5199965	3	11	S	0	0	999.01	1
5199965	4	11	S	0	0	2000	1

**Table C41 Market bids for time interval 11:00-12:00
(continued)**

5199986	1	11	S	0	0	0	1
5199986	2	11	S	0	0	2000	1
5200084	1	11	S	375	37,5	0	1
5200084	2	11	S	375	37,5	2000	1
5200118	1	11	S	8	0,8	0	1
5200118	2	11	S	8	0,8	100	1
5200118	3	11	S	-67	-6,7	100.01	1
5200118	4	11	S	-67	-6,7	2000	1
5200139	1	11	S	2332	233,2	0	1
5200139	2	11	S	2332	233,2	200	1
5200139	3	11	S	2332	233,2	200.1	1
5200139	4	11	S	2332	233,2	250	1
5200139	5	11	S	0	0	250.1	1
5200139	6	11	S	0	0	300	1
5200139	7	11	S	0	0	300.1	1
5200139	8	11	S	0	0	2000	1
5200222	1	11	S	-170	-17	0	1
5200222	2	11	S	-170	-17	209.99	1
5200222	3	11	S	-440	-44	210	1
5200222	4	11	S	-440	-44	2000	1
5200272	1	11	S	0	0	0	1
5200272	2	11	S	0	0	2000	1
5200382	1	11	S	150	15	0	1
5200382	2	11	S	150	15	500	1
5200382	3	11	S	0	0	501	1
5200382	4	11	S	0	0	2000	1
5200432	1	11	S	0	0	0	1
5200432	2	11	S	0	0	155.27	1
5200432	3	11	S	0	0	170.8	1
5200432	4	11	S	0	0	2000	1
5200596	1	11	S	-150	-15	0	1
5200596	2	11	S	-150	-15	4	1
5200596	3	11	S	-1750	-175	5	1
5200596	4	11	S	-1750	-175	8	1
5200596	5	11	S	-2850	-285	9	1
5200596	6	11	S	-2850	-285	2000	1
5200609	1	11	S	0	0	0	1
5200609	2	11	S	0	0	75	1
5200609	3	11	S	-10	-1	75.99	1
5200609	4	11	S	-11	-1,1	89.99	1
5200609	5	11	S	-12	-1,2	169.91	1

**Table C42 Market bids for time interval 11:00-12:00
(continued)**

5200609	6	11	S	-14	-1,4	200.01	1
5200609	7	11	S	-20	-2	2000	1
5200758	1	11	S	-13	-1,3	0	1
5200758	2	11	S	-13	-1,3	2000	1
5200811	1	11	S	0	0	0	1
5200811	2	11	S	0	0	144.99	1
5200811	3	11	S	-7	-0,7	145	1
5200811	4	11	S	-7	-0,7	2000	1
5200890	1	11	S	-18	-1,8	0	1
5200890	2	11	S	-18	-1,8	2000	1
5200912	1	11	S	-22	-2,2	0	1
5200912	2	11	S	-22	-2,2	2000	1
5200959	1	11	S	48	4,8	0	1
5200959	2	11	S	48	4,8	2000	1
5201004	1	11	S	-38	-3,8	0	1
5201004	2	11	S	-38	-3,8	2000	1
5201038	1	11	S	2220	222	0	1
5201038	2	11	S	2220	222	91	1
5201038	3	11	S	2008	200,8	91.01	1
5201038	4	11	S	2008	200,8	109.99	1
5201038	5	11	S	1718	171,8	110	1
5201038	6	11	S	1718	171,8	119.99	1
5201038	7	11	S	1578	157,8	120	1
5201038	8	11	S	1578	157,8	129.99	1
5201038	9	11	S	1428	142,8	130	1
5201038	10	11	S	1428	142,8	139.99	1
5201038	11	11	S	1368	136,8	140	1
5201038	12	11	S	1368	136,8	2000	1
5201108	1	11	S	-1	-0,1	0	1
5201108	2	11	S	-1	-0,1	2000	1
5201166	1	11	S	-18	-1,8	0	1
5201166	2	11	S	-18	-1,8	2000	1
5201175	1	11	S	0	0	0	1
5201175	2	11	S	0	0	145	1
5201175	3	11	S	-16	-1,6	145.01	1
5201175	4	11	S	-16	-1,6	2000	1
5201203	1	11	S	1612	161,2	0	1
5201203	2	11	S	1612	161,2	2000	1
5201239	1	11	S	56	5,6	0	1
5201239	2	11	S	56	5,6	2000	1
5201353	1	11	S	-9	-0,9	0	1

**Table C43 Market bids for time interval 11:00-12:00
(continued)**

5201353	2	11	S	-9	-0,9	2000	1
5201393	1	11	S	1500	150	0	1
5201393	2	11	S	1500	150	2000	1
5201433	1	11	S	0	0	0	1
5201433	2	11	S	0	0	2000	1
5201473	1	11	S	-113	-11,3	0	1
5201473	2	11	S	-113	-11,3	2000	1
5201492	1	11	S	3	0,3	0	1
5201492	2	11	S	3	0,3	172.98	1
5201492	3	11	S	3	0,3	172.99	1
5201492	4	11	S	3	0,3	176.98	1
5201492	5	11	S	3	0,3	176.99	1
5201492	6	11	S	3	0,3	182.98	1
5201492	7	11	S	3	0,3	182.99	1
5201492	8	11	S	3	0,3	188.98	1
5201492	9	11	S	3	0,3	188.99	1
5201492	10	11	S	3	0,3	197.98	1
5201492	11	11	S	-197	-19,7	197.99	1
5201492	12	11	S	-197	-19,7	221.98	1
5201492	13	11	S	-197	-19,7	221.99	1
5201492	14	11	S	-197	-19,7	2000	1
5201520	1	11	S	0	0	0	1
5201520	2	11	S	0	0	2000	1
5201553	1	11	S	0	0	0	1
5201553	2	11	S	0	0	84.99	1
5201553	3	11	S	0	0	85	1
5201553	4	11	S	0	0	109.99	1
5201553	5	11	S	0	0	110	1
5201553	6	11	S	0	0	124.99	1
5201553	7	11	S	0	0	125	1
5201553	8	11	S	0	0	144.99	1
5201553	9	11	S	-30	-3	145	1
5201553	10	11	S	-30	-3	2000	1
5201599	1	11	S	-440	-44	0	1
5201599	2	11	S	-440	-44	2000	1
5201620	1	11	S	-6	-0,6	0	1
5201620	2	11	S	-6	-0,6	2000	1
5201669	1	11	S	-3	-0,3	0	1
5201669	2	11	S	-3	-0,3	2000	1
5201689	1	11	S	-4010	-401	0	1
5201689	2	11	S	-4010	-401	2000	1

**Table C44 Market bids for time interval 11:00-12:00
(continued)**

5201732	1	11	S	55	5,5	0	1
5201732	2	11	S	55	5,5	2000	1
5201863	1	11	S	0	0	0	1
5201863	2	11	S	0	0	84.99	1
5201863	3	11	S	0	0	85	1
5201863	4	11	S	0	0	109.99	1
5201863	5	11	S	0	0	110	1
5201863	6	11	S	0	0	124.99	1
5201863	7	11	S	0	0	125	1
5201863	8	11	S	0	0	144.99	1
5201863	9	11	S	-70	-7	145	1
5201863	10	11	S	-70	-7	2000	1
5201989	1	11	S	467	46,7	0	1
5201989	2	11	S	467	46,7	2000	1
5202036	1	11	S	0	0	0	1
5202036	2	11	S	0	0	120	1
5202036	3	11	S	-30	-3	170	1
5202036	4	11	S	-30	-3	2000	1
5202085	1	11	S	0	0	0	1
5202085	2	11	S	0	0	74.99	1
5202085	3	11	S	0	0	75	1
5202085	4	11	S	0	0	104.99	1
5202085	5	11	S	-20	-2	105	1
5202085	6	11	S	-20	-2	124.99	1
5202085	7	11	S	-20	-2	125	1
5202085	8	11	S	-20	-2	2000	1
5202204	1	11	S	-110	-11	0	1
5202204	2	11	S	-110	-11	144.99	1
5202204	3	11	S	-1250	-125	145	1
5202204	4	11	S	-1250	-125	169.99	1
5202204	5	11	S	-1250	-125	170	1
5202204	6	11	S	-1250	-125	194.99	1
5202204	7	11	S	-1250	-125	195	1
5202204	8	11	S	-1250	-125	2000	1
5202223	1	11	S	16	1,6	0	1
5202223	2	11	S	16	1,6	2000	1
5202282	1	11	S	124	12,4	0	1
5202282	2	11	S	123	12,3	75	1
5202282	3	11	S	122	12,2	99	1
5202282	4	11	S	122	12,2	129	1
5202282	5	11	S	121	12,1	149	1

**Table C45 Market bids for time interval 11:00-12:00
(continued)**

5202282	6	11	S	121	12,1	159	1
5202282	7	11	S	121	12,1	2000	1
5202402	1	11	S	-5	-0,5	0	1
5202402	2	11	S	-5	-0,5	2000	1
5202677	1	11	S	-140	-14	0	1
5202677	2	11	S	-140	-14	2000	1
5202696	1	11	S	114	11,4	0	1
5202696	2	11	S	114	11,4	2000	1
5202787	1	11	S	2304	230,4	0	1
5202787	2	11	S	2304	230,4	2000	1
5202810	1	11	S	59	5,9	0	1
5202810	2	11	S	59	5,9	185.98	1
5202810	3	11	S	-13	-1,3	185.99	1
5202810	4	11	S	-13	-1,3	204.98	1
5202810	5	11	S	-219	-21,9	204.99	1
5202810	6	11	S	-219	-21,9	2000	1
5202842	1	11	S	0	0	0	1
5202842	2	11	S	0	0	139.99	1
5202842	3	11	S	0	0	140	1
5202842	4	11	S	0	0	149.99	1
5202842	5	11	S	0	0	150	1
5202842	6	11	S	0	0	179.99	1
5202842	7	11	S	-60	-6	180	1
5202842	8	11	S	-60	-6	2000	1
5202903	1	11	S	24	2,4	0	1
5202903	2	11	S	24	2,4	2000	1
5202925	1	11	S	-3	-0,3	0	1
5202925	2	11	S	-3	-0,3	2000	1
5203026	1	11	S	0	0	0	1
5203026	2	11	S	0	0	184.99	1
5203026	3	11	S	-2100	-210	185	1
5203026	4	11	S	-2100	-210	2000	1
5203054	1	11	S	74	7,4	0	1
5203054	2	11	S	74	7,4	2000	1
5203293	1	11	S	-35	-3,5	0	1
5203293	2	11	S	-35	-3,5	2000	1
5203324	1	11	S	-30	-3	0	1
5203324	2	11	S	-30	-3	2000	1
5203335	1	11	S	345	34,5	0	1
5203335	2	11	S	345	34,5	180	1
5203335	3	11	S	300	30	400	1

**Table C46 Market bids for time interval 11:00-12:00
(continued)**

5203335	4	11	S	250	25	500	1
5203335	5	11	S	200	20	550	1
5203335	6	11	S	0	0	2000	1
5203407	1	11	S	4	0,4	0	1
5203407	2	11	S	0	0	140	1
5203407	3	11	S	-37	-3,7	155	1
5203407	4	11	S	-38	-3,8	180	1
5203407	5	11	S	-38	-3,8	2000	1
5203454	1	11	S	40	4	0	1
5203454	2	11	S	40	4	2000	1
5203559	1	11	S	7900	790	0	1
5203559	2	11	S	7900	790	160	1
5203559	3	11	S	7650	765	193	1
5203559	4	11	S	6650	665	240	1
5203559	5	11	S	0	0	250	1
5203559	6	11	S	0	0	500	1
5203559	7	11	S	0	0	2000	1
5203597	1	11	S	0	0	0	1
5203597	2	11	S	0	0	299.99	1
5203597	3	11	S	-200	-20	300	1
5203597	4	11	S	-200	-20	2000	1
5203632	1	11	S	-300	-30	0	1
5203632	2	11	S	-300	-30	2000	1
5203661	1	11	S	0	0	0	1
5203661	2	11	S	0	0	155.68	1
5203661	3	11	S	-170	-17	155.69	1
5203661	4	11	S	-170	-17	2000	1
5203726	1	11	S	-380	-38	0	1
5203726	2	11	S	-380	-38	2000	1
5203754	1	11	S	-15	-1,5	0	1
5203754	2	11	S	-15	-1,5	2000	1
5203765	1	11	S	-211	-21,1	0	1
5203765	2	11	S	-211	-21,1	2000	1
5203852	1	11	S	-155	-15,5	0	1
5203852	2	11	S	-155	-15,5	2000	1
5203913	1	11	B	-600	-60	190	14
5203922	1	11	S	-13	-1,3	0	1
5203922	2	11	S	-13	-1,3	2000	1
5203960	1	11	S	3	0,3	0	1
5203960	2	11	S	3	0,3	209.99	1
5203960	3	11	S	3	0,3	210	1

**Table C47 Market bids for time interval 11:00-12:00
(continued)**

5203960	4	11	S	3	0,3	2000	1
5203972	1	11	S	-235	-23,5	0	1
5203972	2	11	S	-235	-23,5	2000	1
5204030	1	11	S	-20	-2	0	1
5204030	2	11	S	-20	-2	2000	1
5204060	1	11	S	0	0	0	1
5204060	2	11	S	0	0	29.98	1
5204060	3	11	S	0	0	29.99	1
5204060	4	11	S	0	0	119.98	1
5204060	5	11	S	-15	-1,5	119.99	1
5204060	6	11	S	-15	-1,5	2000	1
5204067	1	11	S	-20	-2	0	1
5204067	2	11	S	-20	-2	639	1
5204067	3	11	S	-260	-26	640	1
5204067	4	11	S	-260	-26	2000	1
5204100	1	11	S	3	0,3	0	1
5204100	2	11	S	3	0,3	2000	1
5204129	1	11	S	50520	5052	0	1
5204129	2	11	S	50520	5052	2	1
5204129	3	11	S	37840	3784	3	1
5204129	4	11	S	37840	3784	7	1
5204129	5	11	S	31860	3186	10	1
5204129	6	11	S	31860	3186	25.99	1
5204129	7	11	S	22190	2219	26	1
5204129	8	11	S	22190	2219	34.99	1
5204129	9	11	S	10030	1003	35	1
5204129	10	11	S	10030	1003	38.99	1
5204129	11	11	S	9740	974	39	1
5204129	12	11	S	9740	974	60.99	1
5204129	13	11	S	9690	969	61	1
5204129	14	11	S	9690	969	63.99	1
5204129	15	11	S	0	0	64	1
5204129	16	11	S	0	0	66.99	1
5204129	17	11	S	0	0	67	1
5204129	18	11	S	0	0	199.99	1
5204129	19	11	S	-1000	-100	200	1
5204129	20	11	S	-1000	-100	200.99	1
5204129	21	11	S	-2000	-200	201	1
5204129	22	11	S	-2000	-200	201.99	1
5204129	23	11	S	-3000	-300	202	1
5204129	24	11	S	-3000	-300	202.99	1

**Table C48 Market bids for time interval 11:00-12:00
(continued)**

5204129	25	11	S	-6000	-600	203	1
5204129	26	11	S	-6000	-600	205.99	1
5204129	27	11	S	10000	-1000	206	1
5204129	28	11	S	10000	-1000	209.99	1
5204129	29	11	S	37410	-3741	210	1
5204129	30	11	S	37410	-3741	2000	1
5204157	1	11	S	0	0	0	1
5204157	2	11	S	0	0	35.99	1
5204157	3	11	S	0	0	36	1
5204157	4	11	S	0	0	168.99	1
5204157	5	11	S	0	0	169	1
5204157	6	11	S	0	0	2000	1
5204165	1	11	S	582	58,2	0	1
5204165	2	11	S	582	58,2	33.99	1
5204165	3	11	S	0	0	34	1
5204165	4	11	S	0	0	171.99	1
5204165	5	11	S	0	0	172	1
5204165	6	11	S	0	0	2000	1
5204207	1	11	S	-441	-44,1	0	1
5204207	2	11	S	-441	-44,1	169.93	1
5204207	3	11	S	-1011	101,1	169.94	1
5204207	4	11	S	-1011	101,1	2000	1
5204231	1	11	S	0	0	0	1
5204231	2	11	S	0	0	61.99	1
5204231	3	11	S	0	0	62	1
5204231	4	11	S	0	0	174.99	1
5204231	5	11	S	0	0	175	1
5204231	6	11	S	0	0	2000	1
5204246	1	11	S	0	0	0	1
5204246	2	11	S	0	0	65.99	1
5204246	3	11	S	0	0	66	1
5204246	4	11	S	0	0	345.99	1
5204246	5	11	S	-988	-98,8	346	1
5204246	6	11	S	-988	-98,8	2000	1
5204308	1	11	S	3583	358,3	0	1
5204308	2	11	S	3583	358,3	2000	1
5204368	1	11	S	25	2,5	0	1
5204368	2	11	S	25	2,5	2000	1
5204392	1	11	S	4449	444,9	0	1
5204392	2	11	S	4449	444,9	2000	1
5204428	1	11	S	-45	-4,5	0	1

**Table C49 Market bids for time interval 11:00-12:00
(continued)**

5204428	2	11	S	-45	-4,5	2000	1
5204487	1	11	S	307	30,7	0	1
5204487	2	11	S	307	30,7	77.99	1
5204487	3	11	S	307	30,7	78	1
5204487	4	11	S	307	30,7	100.79	1
5204487	5	11	S	301	30,1	100.8	1
5204487	6	11	S	301	30,1	110.27	1
5204487	7	11	S	291	29,1	110.28	1
5204487	8	11	S	291	29,1	132.51	1
5204487	9	11	S	291	29,1	132.52	1
5204487	10	11	S	291	29,1	205.69	1
5204487	11	11	S	46	4,6	205.7	1
5204487	12	11	S	46	4,6	224.69	1
5204487	13	11	S	-203	-20,3	224.7	1
5204487	14	11	S	-203	-20,3	2000	1
5204497	1	11	S	11	1,1	0	1
5204497	2	11	S	11	1,1	2000	1
5204523	1	11	S	0	0	0	1
5204523	2	11	S	0	0	5	1
5204523	3	11	S	0	0	10	1
5204523	4	11	S	0	0	50	1
5204523	5	11	S	0	0	100	1
5204523	6	11	S	0	0	150	1
5204523	7	11	S	0	0	189.99	1
5204523	8	11	S	-46	-4,6	190	1
5204523	9	11	S	-46	-4,6	200	1
5204523	10	11	S	-46	-4,6	250	1
5204523	11	11	S	-46	-4,6	300	1
5204523	12	11	S	-46	-4,6	350	1
5204523	13	11	S	-46	-4,6	400	1
5204523	14	11	S	-46	-4,6	449.99	1
5204523	15	11	S	-376	-37,6	450	1
5204523	16	11	S	-376	-37,6	750	1
5204523	17	11	S	-376	-37,6	1000	1
5204523	18	11	S	-376	-37,6	1500	1
5204523	19	11	S	-376	-37,6	2000	1
5204550	1	11	S	200	20	0	1
5204550	2	11	S	125	12,5	130	1
5204550	3	11	S	0	0	2000	1
5204566	1	11	S	240	24	0	1
5204566	2	11	S	240	24	99.99	1

**Table C50 Market bids for time interval 11:00-12:00
(continued)**

5204566	3	11	S	240	24	100	1
5204566	4	11	S	240	24	140	1
5204566	5	11	S	240	24	180	1
5204566	6	11	S	240	24	2000	1
5204644	1	11	S	-60	-6	0	1
5204644	2	11	S	-60	-6	2000	1
5204801	1	11	S	-220	-22	0	1
5204801	2	11	S	-220	-22	2000	1
5204840	1	11	S	-12	-1,2	0	1
5204840	2	11	S	-12	-1,2	179.99	1
5204840	3	11	S	-12	-1,2	180	1
5204840	4	11	S	-12	-1,2	200	1
5204840	5	11	S	-12	-1,2	2000	1
5204857	1	11	S	-9	-0,9	0	1
5204857	2	11	S	-9	-0,9	2000	1
5204918	1	11	S	20	2	0	1
5204918	2	11	S	20	2	2000	1
5205011	1	11	S	-70	-7	0	1
5205011	2	11	S	-70	-7	2000	1
5205134	1	11	S	-485	-48,5	0	1
5205134	2	11	S	-485	-48,5	2000	1
5205154	1	11	S	413	41,3	0	1
5205154	2	11	S	413	41,3	259.99	1
5205154	3	11	S	53	5,3	260	1
5205154	4	11	S	53	5,3	2000	1
5205231	1	11	S	1200	120	0	1
5205231	2	11	S	1200	120	115	1
5205231	3	11	S	0	0	115.01	1
5205231	4	11	S	0	0	131.99	1
5205231	5	11	S	-1420	-142	132	1
5205231	6	11	S	-1420	-142	191.99	1
5205231	7	11	S	-2040	-204	192	1
5205231	8	11	S	-2040	-204	2000	1
5205303	1	11	S	-14	-1,4	0	1
5205303	2	11	S	-14	-1,4	2000	1
5205335	1	11	S	-80	-8	0	1
5205335	2	11	S	-80	-8	99.99	1
5205335	3	11	S	-80	-8	100	1
5205335	4	11	S	-80	-8	140	1
5205335	5	11	S	-80	-8	180	1
5205335	6	11	S	-80	-8	2000	1

Table C51 Market bids for time interval 11:00-12:00
(continued)

5205501	1	11	S	339	33,9	0	1
5205501	2	11	S	339	33,9	2000	1
5205601	1	11	S	-21	-2,1	0	1
5205601	2	11	S	-21	-2,1	2000	1
5205641	1	11	S	-140	-14	0	1
5205641	2	11	S	-140	-14	2000	1
5205679	1	11	S	-35	-3,5	0	1
5205679	2	11	S	-35	-3,5	2000	1
5205726	1	11	S	-129	-12,9	0	1
5205726	2	11	S	-129	-12,9	2000	1
5205762	1	11	S	193	19,3	0	1
5205762	2	11	S	193	19,3	2000	1
5205804	1	11	S	-10	-1	0	1
5205804	2	11	S	-10	-1	2000	1
5205832	1	11	S	-139	-13,9	0	1
5205832	2	11	S	-139	-13,9	2000	1
5205867	1	11	S	25	2,5	0	1
5205867	2	11	S	25	2,5	2000	1
5205931	1	11	S	1515	151,5	0	1
5205931	2	11	S	1515	151,5	89.99	1
5205931	3	11	S	1325	132,5	90	1
5205931	4	11	S	1325	132,5	140	1
5205931	5	11	S	-195	-19,5	140.01	1
5205931	6	11	S	-195	-19,5	144.99	1
5205931	7	11	S	-2025	202,5	145	1
5205931	8	11	S	-2025	202,5	2000	1
5205961	1	11	S	-40	-4	0	1
5205961	2	11	S	-40	-4	2000	1
5206135	1	11	S	-46	-4,6	0	1
5206135	2	11	S	-46	-4,6	2000	1
5206308	1	11	S	0	0	0	1
5206308	2	11	S	0	0	2000	1
5206338	1	11	S	0	0	0	1
5206338	2	11	S	0	0	2000	1
5206426	1	11	S	1344	134,4	0	1
5206426	2	11	S	1344	134,4	2000	1
5206438	1	11	S	-15	-1,5	0	1
5206438	2	11	S	-15	-1,5	2000	1
5206477	1	11	S	4	0,4	0	1
5206477	2	11	S	4	0,4	2000	1
5206486	1	11	S	-380	-38	0	1

**Table C52 Market bids for time interval 11:00-12:00
(continued)**

5206486	2	11	S	-380	-38	167.99	1
5206486	3	11	S	-390	-39	168	1
5206486	4	11	S	-390	-39	169.99	1
5206486	5	11	S	-390	-39	170	1
5206486	6	11	S	-390	-39	174.99	1
5206486	7	11	S	-410	-41	175	1
5206486	8	11	S	-410	-41	2000	1
5206519	1	11	S	305	30,5	0	1
5206519	2	11	S	305	30,5	2000	1
5206559	1	11	S	-1510	-151	0	1
5206559	2	11	S	-1510	-151	2000	1
5206624	1	11	S	0	0	0	1
5206624	2	11	S	0	0	2000	1
5206666	1	11	S	-100	-10	0	1
5206666	2	11	S	-100	-10	2000	1
5206699	1	11	S	-7	-0,7	0	1
5206699	2	11	S	-7	-0,7	2000	1
5206734	1	11	S	620	62	0	1
5206734	2	11	S	620	62	2000	1
5206862	1	11	S	-50	-5	0	1
5206862	2	11	S	-50	-5	2000	1
5206902	1	11	S	1361	136,1	0	1
5206902	2	11	S	1361	136,1	2000	1
5206949	1	11	S	10	1	0	1
5206949	2	11	S	10	1	2000	1
5206955	1	11	S	155	15,5	0	1
5206955	2	11	S	155	15,5	2000	1
5207005	1	11	S	0	0	0	1
5207005	2	11	S	0	0	198.99	1
5207005	3	11	S	-1600	-160	199	1
5207005	4	11	S	-1600	-160	209.99	1
5207005	5	11	S	-4800	-480	210	1
5207005	6	11	S	-4800	-480	2000	1
5207126	1	11	S	60	6	0	1
5207126	2	11	S	60	6	2000	1
5207174	1	11	S	-220	-22	0	1
5207174	2	11	S	-220	-22	2000	1
5207295	1	11	S	5	0,5	0	1
5207295	2	11	S	5	0,5	59.99	1
5207295	3	11	S	5	0,5	70.99	1
5207295	4	11	S	5	0,5	80	1

**Table C53 Market bids for time interval 11:00-12:00
(continued)**

5207295	5	11	S	5	0,5	119	1
5207295	6	11	S	-2	-0,2	120	1
5207295	7	11	S	-3	-0,3	149.99	1
5207295	8	11	S	-8	-0,8	169.99	1
5207295	9	11	S	-8	-0,8	172.99	1
5207295	10	11	S	-8	-0,8	179.99	1
5207295	11	11	S	-8	-0,8	196.01	1
5207295	12	11	S	-9	-0,9	230	1
5207295	13	11	S	-20	-2	500	1
5207295	14	11	S	-30	-3	2000	1
5207377	1	11	S	-86	-8,6	0	1
5207377	2	11	S	-86	-8,6	2000	1
5207407	1	11	S	3356	335,6	0	1
5207407	2	11	S	3356	335,6	2000	1
5207502	1	11	S	-1315	131,5	0	1
5207502	2	11	S	-1315	131,5	2000	1
5207519	1	11	S	0	0	0	1
5207519	2	11	S	0	0	180.99	1
5207519	3	11	S	-700	-70	181	1
5207519	4	11	S	-700	-70	2000	1
5207557	1	11	S	5250	525	0	1
5207557	2	11	S	5250	525	140	1
5207557	3	11	S	5250	525	140.1	1
5207557	4	11	S	5250	525	150	1
5207557	5	11	S	5250	525	150.1	1
5207557	6	11	S	5250	525	200	1
5207557	7	11	S	5250	525	200.1	1
5207557	8	11	S	5250	525	300	1
5207557	9	11	S	5250	525	300.1	1
5207557	10	11	S	5250	525	500	1
5207557	11	11	S	5250	525	500.1	1
5207557	12	11	S	5250	525	1000	1
5207557	13	11	S	5250	525	1000.1	1
5207557	14	11	S	5250	525	2000	1
5207582	1	11	S	-20	-2	0	1
5207582	2	11	S	-20	-2	2000	1
5207591	1	11	S	111	11,1	0	1
5207591	2	11	S	111	11,1	2000	1
5207635	1	11	S	0	0	0	1
5207635	2	11	S	0	0	2000	1
5207705	1	11	S	74	7,4	0	1

**Table C54 Market bids for time interval 11:00-12:00
(continued)**

5207705	2	11	S	74	7,4	2000	1
5207712	1	11	S	-19	-1,9	0	1
5207712	2	11	S	-19	-1,9	2000	1
5207742	1	11	S	7460	746	0	1
5207742	2	11	S	7460	746	35	1
5207742	3	11	S	4660	466	35.1	1
5207742	4	11	S	4660	466	40	1
5207742	5	11	S	4660	466	40.1	1
5207742	6	11	S	4660	466	100	1
5207742	7	11	S	420	42	100.1	1
5207742	8	11	S	420	42	110	1
5207742	9	11	S	0	0	110.1	1
5207742	10	11	S	0	0	129.9	1
5207742	11	11	S	0	0	130	1
5207742	12	11	S	0	0	134.9	1
5207742	13	11	S	0	0	135	1
5207742	14	11	S	0	0	149.9	1
5207742	15	11	S	0	0	150	1
5207742	16	11	S	0	0	309.9	1
5207742	17	11	S	0	0	310	1
5207742	18	11	S	0	0	329.9	1
5207742	19	11	S	-1057	105,7	330	1
5207742	20	11	S	-1057	105,7	359.9	1
5207742	21	11	S	-1242	124,2	360	1
5207742	22	11	S	-1242	124,2	2000	1
5207831	1	11	S	-825	-82,5	0	1
5207831	2	11	S	-825	-82,5	2000	1
5207857	1	11	S	-1160	-116	0	1
5207857	2	11	S	-1160	-116	100	1
5207857	3	11	S	-1160	-116	100.01	1
5207857	4	11	S	-1160	-116	185	1
5207857	5	11	S	-1160	-116	185.01	1
5207857	6	11	S	-1160	-116	190	1
5207857	7	11	S	-1160	-116	190.01	1
5207857	8	11	S	-1160	-116	200	1
5207857	9	11	S	-2290	-229	200.01	1
5207857	10	11	S	-2290	-229	250	1
5207857	11	11	S	-2290	-229	2000	1
5207862	1	11	S	2	0,2	0	1
5207862	2	11	S	2	0,2	20	1
5207862	3	11	S	2	0,2	30	1

**Table C55 Market bids for time interval 11:00-12:00
(continued)**

5207862	4	11	S	2	0,2	90	1
5207862	5	11	S	2	0,2	100	1
5207862	6	11	S	2	0,2	110	1
5207862	7	11	S	2	0,2	120	1
5207862	8	11	S	2	0,2	132	1
5207862	9	11	S	2	0,2	145	1
5207862	10	11	S	2	0,2	150	1
5207862	11	11	S	2	0,2	155	1
5207862	12	11	S	2	0,2	159	1
5207862	13	11	S	2	0,2	160	1
5207862	14	11	S	-90	-9	162	1
5207862	15	11	S	-100	-10	166	1
5207862	16	11	S	-100	-10	168	1
5207862	17	11	S	-110	-11	170	1
5207862	18	11	S	-150	-15	175	1
5207862	19	11	S	-170	-17	180	1
5207862	20	11	S	-170	-17	182	1
5207862	21	11	S	-200	-20	185	1
5207862	22	11	S	-200	-20	187	1
5207862	23	11	S	-200	-20	190	1
5207862	24	11	S	-290	-29	193	1
5207862	25	11	S	-350	-35	195	1
5207862	26	11	S	-480	-48	197	1
5207862	27	11	S	-585	-58,5	205	1
5207862	28	11	S	-585	-58,5	210	1
5207862	29	11	S	-585	-58,5	215	1
5207862	30	11	S	-585	-58,5	220	1
5207862	31	11	S	-585	-58,5	225	1
5207862	32	11	S	-585	-58,5	230	1
5207862	33	11	S	-585	-58,5	240	1
5207862	34	11	S	-585	-58,5	250	1
5207862	35	11	S	-600	-60	300	1
5207862	36	11	S	-600	-60	400	1
5207862	37	11	S	-600	-60	2000	1
5207998	1	11	S	0	0	0	1
5207998	2	11	S	0	0	2000	1
5208026	1	11	S	0	0	0	1
5208026	2	11	S	0	0	23.13	1
5208026	3	11	S	0	0	23.14	1
5208026	4	11	S	0	0	23.15	1
5208026	5	11	S	0	0	2000	1

**Table C56 Market bids for time interval 11:00-12:00
(continued)**

5208082	1	11	S	0	0	0	1
5208082	2	11	S	0	0	2000	1
5208158	1	11	S	38	3,8	0	1
5208158	2	11	S	38	3,8	2000	1
5208336	1	11	S	-20	-2	0	1
5208336	2	11	S	-20	-2	2000	1
5208371	1	11	S	-131	-13,1	0	1
5208371	2	11	S	-131	-13,1	2000	1
5208419	1	11	S	-1520	-152	0	1
5208419	2	11	S	-1520	-152	89.99	1
5208419	3	11	S	-1520	-152	90	1
5208419	4	11	S	-1520	-152	2000	1
5208459	1	11	S	142	14,2	0	1
5208459	2	11	S	142	14,2	250	1
5208459	3	11	S	0	0	250.01	1
5208459	4	11	S	0	0	2000	1
5208524	1	11	S	-7	-0,7	0	1
5208524	2	11	S	-7	-0,7	2000	1
5208544	1	11	S	171	17,1	0	1
5208544	2	11	S	171	17,1	2000	1
5208562	1	11	S	400	40	0	1
5208562	2	11	S	400	40	77.75	1
5208562	3	11	S	400	40	77.76	1
5208562	4	11	S	400	40	144.99	1
5208562	5	11	S	-300	-30	145	1
5208562	6	11	S	-300	-30	164.99	1
5208562	7	11	S	-300	-30	165	1
5208562	8	11	S	-300	-30	169.99	1
5208562	9	11	S	-300	-30	170	1
5208562	10	11	S	-300	-30	174.99	1
5208562	11	11	S	-300	-30	175	1
5208562	12	11	S	-300	-30	180.44	1
5208562	13	11	S	-830	-83	180.45	1
5208562	14	11	S	-830	-83	322.84	1
5208562	15	11	S	-830	-83	322.85	1
5208562	16	11	S	-830	-83	2000	1
5208630	1	11	S	-4	-0,4	0	1
5208630	2	11	S	-4	-0,4	2000	1
5208687	1	11	S	-534	-53,4	0	1
5208687	2	11	S	-534	-53,4	169.99	1
5208687	3	11	S	-534	-53,4	170	1

Table C57 Market bids for time interval 11:00-12:00
(continued)

5208687	4	11	S	-534	-53,4	2000	1
5208728	1	11	B	-88	-8,8	199	8
5208729	1	11	B	-19	-1,9	199	8
5208730	1	11	B	-73	-7,3	199	8
5208790	1	11	S	1895	189,5	0	1
5208790	2	11	S	1895	189,5	2000	1
5208819	1	11	S	712	71,2	0	1
5208819	2	11	S	712	71,2	2000	1
5208852	1	11	S	-24	-2,4	0	1
5208852	2	11	S	-24	-2,4	2000	1
5208876	1	11	S	-167	-16,7	0	1
5208876	2	11	S	-167	-16,7	2000	1
5208919	1	11	S	-24	-2,4	0	1
5208919	2	11	S	-24	-2,4	2000	1
5208954	1	11	S	0	0	0	1
5208954	2	11	S	-210	-21	150	1
5208954	3	11	S	-211	-21,1	180	1
5208954	4	11	S	-270	-27	2000	1
5208975	1	11	S	10	1	0	1
5208975	2	11	S	10	1	144	1
5208975	3	11	S	0	0	184.99	1
5208975	4	11	S	-80	-8	185	1
5208975	5	11	S	-80	-8	2000	1
5209017	1	11	S	0	0	0	1
5209017	2	11	S	0	0	10	1
5209017	3	11	S	0	0	150	1
5209017	4	11	S	0	0	174	1
5209017	5	11	S	0	0	174.01	1
5209017	6	11	S	0	0	187	1
5209017	7	11	S	0	0	187.01	1
5209017	8	11	S	0	0	194.59	1
5209017	9	11	S	-60	-6	194.6	1
5209017	10	11	S	-60	-6	198	1
5209017	11	11	S	-60	-6	198.01	1
5209017	12	11	S	-60	-6	201.59	1
5209017	13	11	S	-60	-6	201.6	1
5209017	14	11	S	-60	-6	204.59	1
5209017	15	11	S	-250	-25	204.6	1
5209017	16	11	S	-250	-25	209.59	1
5209017	17	11	S	-442	-44,2	209.6	1
5209017	18	11	S	-442	-44,2	2000	1

**Table C58 Market bids for time interval 11:00-12:00
(continued)**

5209141	1	11	S	17	1,7	0	1
5209141	2	11	S	17	1,7	101	1
5209141	3	11	S	-33	-3,3	101.01	1
5209141	4	11	S	-33	-3,3	2000	1
5209202	1	11	S	0	0	0	1
5209202	2	11	S	0	0	2000	1
5209220	1	11	B	-330	-33	205	8
5209242	1	11	S	23	2,3	0	1
5209242	2	11	S	23	2,3	2000	1
5209288	1	11	S	-284	-28,4	0	1
5209288	2	11	S	-284	-28,4	2000	1
5209317	1	11	S	370	37	0	1
5209317	2	11	S	370	37	2000	1
5209322	1	11	S	0	0	0	1
5209322	2	11	S	-14	-1,4	35	1
5209322	3	11	S	-14	-1,4	2000	1
5209358	1	11	S	-251	-25,1	0	1
5209358	2	11	S	-251	-25,1	2000	1
5209408	1	11	B	2360	236	2000	2